

5 Series

500W11

Geothermal Hydronic Heat Pump

Installation Information

Water Piping Connections

Electrical Data

Startup Procedures

Preventive Maintenance



IM2506WN 01/23

Table of Contents

- Model Nomenclature 4
- General Installation Information 5
- Water Quality 6
- Flow Centers 7
- Field Connected Water Piping..... 8
- Potable Water Systems 11
- Electrical Information 12
- Hydronic Section 17
- Accessories and Options..... 19
- Electrical Data..... 21
- Wiring Schematics 24
- External Control 30
- Converting to a Dedicated Cooling Unit 31
- Unit Startup 32
- The Aurora Base Control System 34
- The Aurora “Advanced” Control System 39
- Reference Calculations, Legend and Notes..... 42
- Pressure Drop and Operating Limits 43
- Physical Data, Flow Rates, and Thermistor and Compressor Resistance 44
- Operating Parameters 45
- Antifreeze Correction 46
- Troubleshooting Guideline for Refrigerant Circuit..... 47
- HR Data 48
- HE Data..... 50
- DHW HE Data 52
- Heating and Cooling Cycle Analysis..... 53
- Troubleshooting Form..... 54
- Troubleshooting 55
- Preventive Maintenance 56
- Service Parts 57
- Revision Guide..... 59

Model Nomenclature

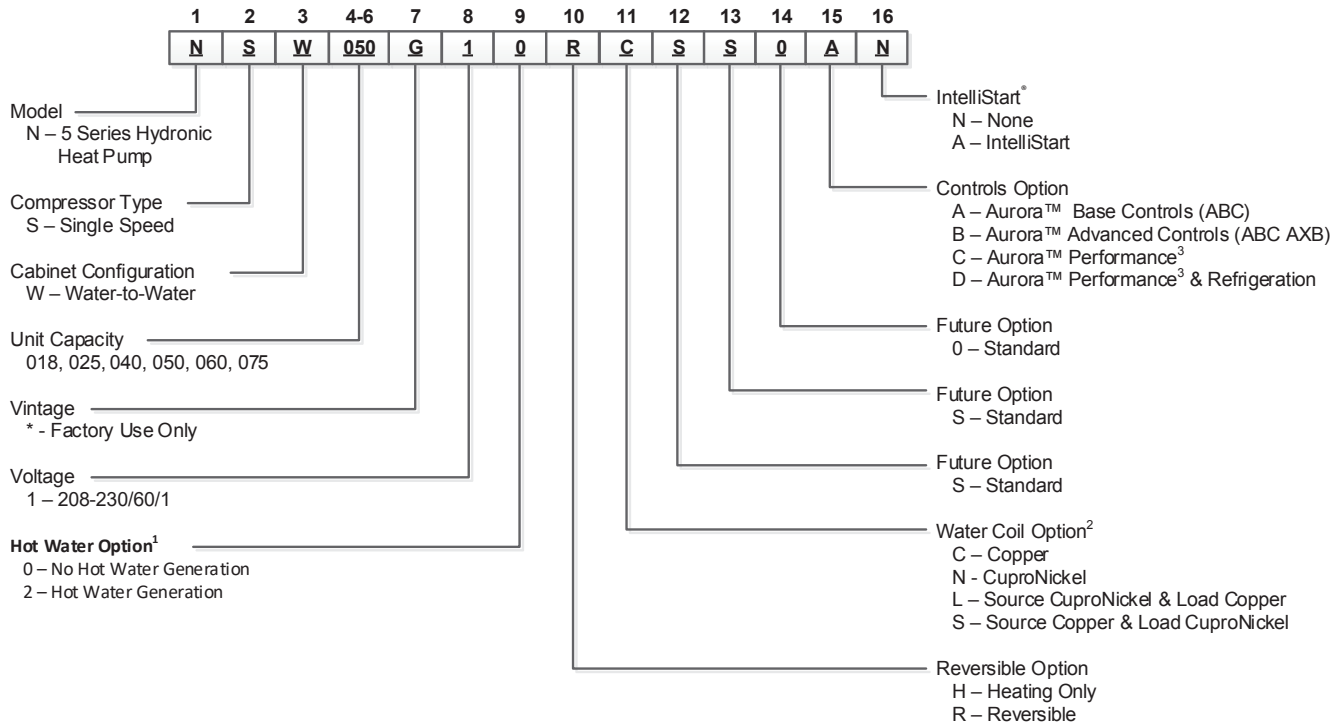

NOTES: 1 – Available on 040, 050, 060, and 075 only. Hot water generator requires field installed external pump kit.
 2 – NSW018 and NSW025 heating only models are available only with copper double wall vented load coil for potable water, and are not designed to be converted to dedicated cooling units.
 3 – Flow meter for Performance option is shipped with unit, and must be externally field installed.

Rev.: 18 January 2016



All 5 Series NSW 500W11 product is safety listed under UL1995 thru ETL and performance listed with AHRI in accordance with standard 13256-2. The 5 Series 500W11 is also ENERGY STAR[®] rated.

General Installation Information

Safety Considerations

Installing and servicing air conditioning and heating equipment can be hazardous due to system pressure and electrical components. Only trained and qualified service personnel should install, repair or service heating and air conditioning equipment. When working on heating and air conditioning equipment, observe precautions in the literature, tags and labels attached to the unit and other safety precautions that may apply.

Follow all safety codes. Wear safety glasses and work gloves. Use quenching cloth for brazing operations. Have fire extinguisher available for all brazing operations.

NOTE: Before installing, check voltage of unit(s) to ensure proper voltage.



WARNING: Before performing service or maintenance operations on the system, turn off main power switches to the unit. Electrical shock could cause serious personal injury.

Process Water Applications

For process water applications, it is recommended that a secondary load heat exchanger be installed to prevent corrosion to the unit's primary coaxial coil. In situations where scaling could be heavy or where biological growth such as iron bacteria will be present, a closed loop system is recommended. Over a period of time, ground water unit heat exchanger coils may lose heat exchange capability due to a buildup of mineral deposits. These can be cleaned only by a qualified service mechanic as special pumping equipment and solutions are required. Never use flexible hoses with a smaller inside diameter than that of water connections.

Moving and Storage

Move units in the normal "Up" orientation as indicated by the labels on the unit packaging. When the equipment is received, all items should be carefully checked against the bill of lading to ensure that all crates and cartons have been received in good condition. Examine units for shipping damage, removing unit packaging if necessary to properly inspect unit. Units in question should also be internally inspected. If any damage is observed, the carrier should make the proper notation on delivery receipt acknowledging the damage. Units are to be stored in a location that provides adequate protection from dirt, debris and moisture.



WARNING: To avoid equipment damage, do not leave the system filled in a building without heat during cold weather, unless adequate freeze protection levels of antifreeze are used. Heat exchangers do not fully drain and will freeze unless protected, causing permanent damage.

Unit Location

Provide sufficient room to make water and electrical connections. If the unit is located in a confined space, provisions must be made for unit servicing. Locate the unit in an indoor area that allows easy removal of the access panels and has enough space for service personnel to perform maintenance or repair. These units are not approved for outdoor installation and, therefore, must be installed inside the structure being conditioned. Do not locate units in areas subject to freezing conditions.



WARNING: Do not store or install units in corrosive environments or in locations subject to temperature or humidity extremes (e.g. attics, garages, rooftops, etc.). Corrosive conditions and high temperature or humidity can significantly reduce performance, reliability, and service life.

Mounting Units

Prior to setting the unit in place, remove and discard the compressor hold down shipping bolt located at the front of the compressor mounting bracket.

Units should be mounted level on a vibration absorbing pad slightly larger than the base to provide isolation between the unit and the floor. It is not necessary to anchor the unit to the floor. Allow access to the front, back, and side access panels for servicing.

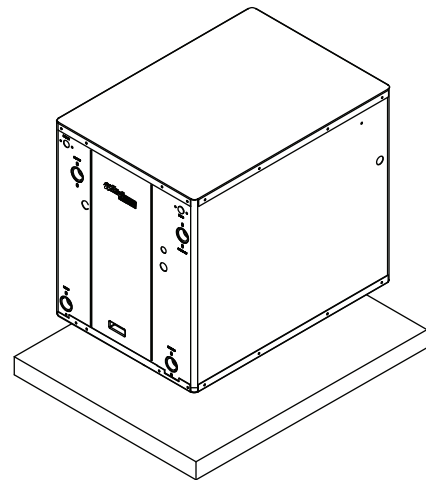

Vibration Pad Mounting

Water Quality

General

Water-to-water heat pumps may be successfully applied in a wide range of residential and light commercial applications. It is the responsibility of the system designer and installing contractor to ensure that acceptable water quality is present and that all applicable codes have been met in these installations. Failure to adhere to the guidelines in the water quality table could result in loss of warranty.

Application

These heat pumps are not intended for direct coupling to swimming pools and spas. If used for this type of application, a secondary heat exchanger must be used. Failure to supply a secondary heat exchanger for this application will result in warranty exclusion for primary heat exchanger corrosion or failure.

Water Treatment

Do not use untreated or improperly treated water. Equipment damage may occur. The use of improperly treated or untreated water in this equipment may result in scaling, erosion, corrosion, algae or slime. The services of a qualified water treatment specialist should be engaged to determine what treatment, if any, is required. The product warranty specifically excludes liability for corrosion, erosion or deterioration of equipment.

The heat exchangers and water lines in the units are copper or cupronickel tube. There may be other materials in the building's piping system that the designer may need to take into consideration when deciding the parameters of the water quality.

If an antifreeze or water treatment solution is to be used, the designer should confirm it does not have a detrimental effect on the materials in the system.

Contaminated Water

In applications where the water quality cannot be held to prescribed limits, the use of a secondary or intermediate heat exchanger is recommended to separate the unit from the contaminated water.

The following table outlines the water quality guidelines for unit heat exchangers. If these conditions are exceeded, a secondary heat exchanger is required. Failure to supply a secondary heat exchanger where needed will result in a warranty exclusion for primary heat exchanger corrosion or failure.



WARNING: Must have intermediate heat exchanger when used in pool and spa applications.

Water Quality Guidelines

Material		Copper	90/10 Cupronickel	316 Stainless Steel
pH	Acidity/Alkalinity	7 - 9	7 - 9	7 - 9
Scaling	Calcium and Magnesium Carbonate	(Total Hardness) less than 350 ppm	(Total Hardness) less than 350 ppm	(Total Hardness) less than 350 ppm
Corrosion	Hydrogen Sulfide	Less than 0.5 ppm (rotten egg smell appears at 0.5 ppm)	10 - 50 ppm	Less than 1 ppm
	Sulfates	Less than 125 ppm	Less than 125 ppm	Less than 200 ppm
	Chlorine	Less than 0.5 ppm	Less than 0.5 ppm	Less than 0.5 ppm
	Chlorides	Less than 20 ppm	Less than 125 ppm	Less than 300 ppm
	Carbon Dioxide	Less than 50 ppm	10 - 50 ppm	10 - 50 ppm
	Ammonia	Less than 2 ppm	Less than 2 ppm	Less than 20 ppm
	Ammonia Chloride	Less than 0.5 ppm	Less than 0.5 ppm	Less than 0.5 ppm
	Ammonia Nitrate	Less than 0.5 ppm	Less than 0.5 ppm	Less than 0.5 ppm
	Ammonia Hydroxide	Less than 0.5 ppm	Less than 0.5 ppm	Less than 0.5 ppm
	Ammonia Sulfate	Less than 0.5 ppm	Less than 0.5 ppm	Less than 0.5 ppm
Iron Fouling (Biological Growth)	Total Dissolved Solids (TDS)	Less than 1000 ppm	1000 - 1500 ppm	1000 - 1500 ppm
	LSI Index	+0.5 to -0.5	+0.5 to -0.5	+0.5 to -0.5
Iron Fouling (Biological Growth)	Iron, FE ²⁺ (Ferrous) Bacterial Iron Potential	< 0.2 ppm	< 0.2 ppm	< 0.2 ppm
	Iron Oxide	Less than 1 ppm, above this level deposition will occur	Less than 1 ppm, above this level deposition will occur	Less than 1 ppm, above this level deposition will occur
Erosion	Suspended Solids	Less than 10 ppm and filtered for max. of 600 micron size	Less than 10 ppm and filtered for max. of 600 micron size	Less than 10 ppm and filtered for max. of 600 micron size
	Threshold Velocity (Fresh Water)	< 6 ft/sec	< 6 ft/sec	< 6 ft/sec

NOTES: Grains = ppm divided by 17
mg/L is equivalent to ppm

2/22/12

Flow Centers

Pressurized Flow Centers:

- Part numbers: FC1-GL, FC2-GL, FC1-FPT, FC2-FPT,FCV1B-GL, FCV2B-GL
- Used with one or two one or multiple heat pumps on a single loop (need to follow installation manual and install check valves)
- Fixed speed and variable speed pumping available.
- Small footprint for mounting location flexibility.
- Can be mounted in several orientations (see flow center manual for acceptable orientations)
- Injection molded and insulated cabinet
- Brass 3-way valves
- Standard hose kits available

Non-Pressurized Flow Center:

- Part numbers: FC1-GLNP, FC2-GLNP, FCV1B-GLNPP, FCV2B-GLNPP
- Used with a single heat pump on a single loop (or two units if using pump sharing feature). Multiple units cannot be installed in parallel with multiple heat pumps on the same loop.
- Fixed speed and variable speed pumping available.
- Floor mounted (larger footprint than pressurized flow centers)
- Design allows for air and debris separation, and easy fluid checking or addition
- Insulated plastic cabinet
- Composite 3-way valves
- GLNPP flow centers use standard hose kit

Non-Pressurized Dual Circuit Flow Centers:

- Part numbers: FC3-GLNPD, FC4-GLNPD, FCV2AB-GLNPD, FCV2BB-GLNPD, FCV3CB-GLNPD, FCV4AB-GLNPD
- Designed for applications with two geothermal heat pumps by eliminating the need for T's, additional piping, check valves, and pump sharing wiring.
- Multiple pump configurations (fixed and variable speed) to match your flow requirements.
- Insulated sheet metal cabinet
- Brass and composite 3-way valves
- Design allows for air and debris separation, and easy fluid checking or addition
- Floor mounted (larger footprint than pressurized flow centers)
- Standard hose kits available

Field Connected Water Piping

General

Each unit is equipped with captive FPT water connections to eliminate 'egg-shaping' from use of a backup wrench. For making the water connections to the unit, a Teflon tape thread sealant is recommended to minimize internal fouling of the piping. Do not over tighten connections. All supply and return water piping should be insulated to prevent excess condensation from forming on the water lines.

NOTE: Units are factory run-tested using propylene glycol. Prior to connecting piping to unit, thoroughly flush heat exchangers.

The piping installation should provide service personnel with the ability to measure water temperatures and pressures. The water lines should be routed so as not to interfere with access to the unit. The use of a short length of high pressure hose with a swivel type fitting may simplify the connections and prevent vibration. Optional stainless steel hose kits are available as an accessory item.

Before final connection to the unit, the supply and return hose kits must be connected, and the system flushed to remove dirt, piping chips and other foreign material. Normally, a combination balancing and close-off (ball) valve is installed at the return, and a rated gate or ball valve is installed at the supply. The return valve can be adjusted to obtain the proper water flow. The valves allow the unit to be removed for servicing.

The proper water flow must be delivered to each unit whenever the unit heats or cools. To assure proper flow, the use of pressure/temperature ports is recommended to determine the flow rate. These ports should be located adjacent to the supply and return connections on the unit. The proper flow rate cannot be accurately set without measuring the water pressure drop through the refrigerant-to-water heat exchanger (See Pressure Drop Table for water flow and pressure drop information). Normally about 3 GPM flow rate per ton of cooling capacity (2.25 GPM per ton minimum) is needed. Both source as well as load fluid piping must be at least as large as the unit connections on the heat pump (larger on long runs).

Never use flexible hoses of a smaller inside diameter than that of the water connection on the unit and limit hose length to 10 ft. per connection. Check carefully for water leaks.



CAUTION: Water piping exposed to outside temperature may be subject to freezing.

Typical Open Loop Installation

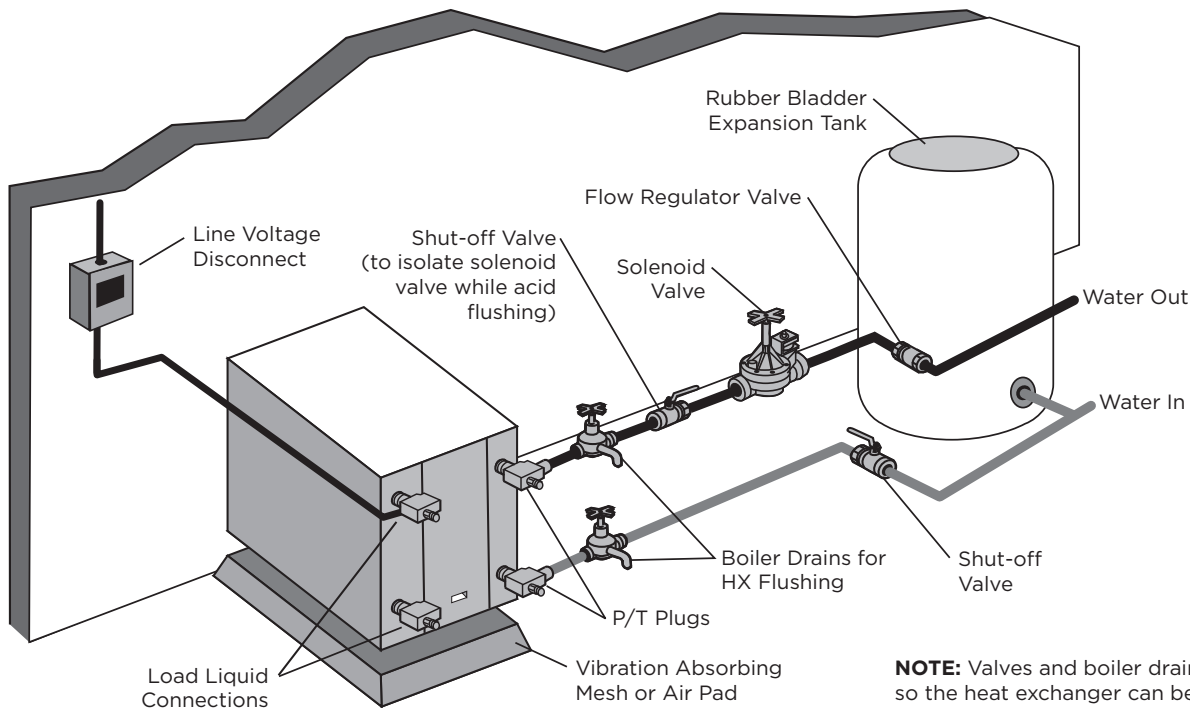

NOTE: Valves and boiler drains must be installed so the heat exchanger can be acid flushed.

Field Connected Water Piping cont.

Earth Coupled Systems with Flow Center

Once piping is completed between the unit, flow center and the earth loop, final purging and charging of the loop is needed. A flush cart (at least a 1.5 HP or 1.12 kW pump) is needed to achieve adequate flow velocity in the loop to purge air and dirt particles from the loop itself. Antifreeze solution is used in most areas to prevent freezing. Maintain the pH in the 7.6-8.2 range for final charging.

Flush the system adequately to remove as much air as possible. Then, pressurize the loop to a static pressure of 50-75 psi [345-517 kPa]. This is normally adequate for good system operation. Ensure that the flow center provides adequate flow through the unit by checking pressure drop across the heat exchanger and by comparing it to the figures shown in the Pressure Drop tables. Usually, 3 GPM/ton [0.054 L/s/kW] L/s/kW or minimum 2.25 GPM/ton [0.04 L/s/kW] of cooling capacity is needed in closed loop earth-coupled applications

Modulating Water Valve Setup

When using a modulating water valve (23P529-01) the use of an AID Tool will be necessary to adjust minimum and maximum flow rates. The factory default is: minimum=50% and maximum=100% flow levels. It is recommended to start with a minimum setting of 65% and adjust from there if necessary. See the 7 Series Variable Speed Pump Setup and Modulating Water Valve Setup instructions within the Unit Startup section which is located in the back of this manual. See Recommended Minimum and Maximum Flow Rates table. Always ensure that there is adequate flow for the heat pump. A modulating water valve is preferred on variable speed system to conserve water.

Figure 1b: Open Loop Solenoid Valve Connection Option
Typical slow operating external 24V water solenoid valve (type V100FPT) wiring.

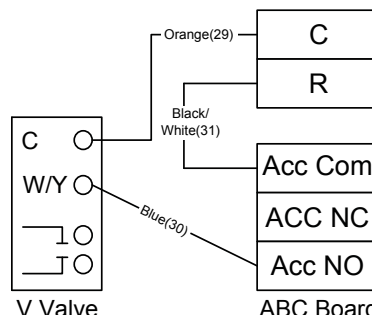

NOTE: SW2-4 should be “ON” and SW2-5 should be “OFF” when using a slow opening (V100FPT) water valve.

Figure 1c: Modulating Water Valve Connection Option
Typical 0-10VDC modulating water valve.

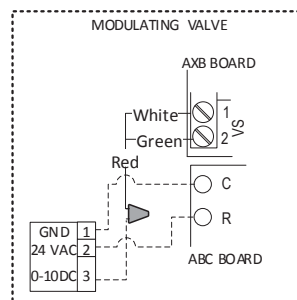
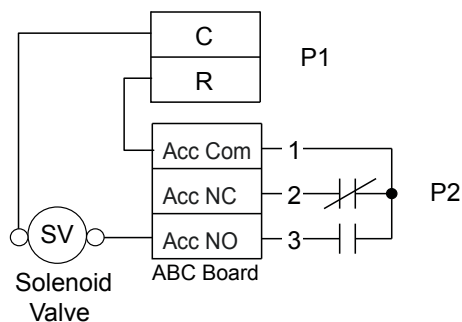

Figure 1a: Open Loop Solenoid Valve Connection Option
Typical quick operating external 24V water solenoid valve (type PPV100 or BPV100) wiring.



NOTE: SW2-4 and SW2-5 should be “OFF” to cycle with the compressor.

Field Connected Water Piping cont.

Open Loop Well Water Systems

Always maintain water pressure in the heat exchanger by placing water control valves at the outlet of the unit. Use a closed bladder type expansion tank to minimize mineral deposits. Ensure proper water flow through the unit by checking pressure drop across the heat exchanger and comparing it to the figures in the pressure drop table. Normally, about 2 GPM flow rate per ton of cooling capacity is needed in open loop systems, (1.5 GPM per ton minimum if entering source temperature is above 50°F [10°C]).

Some water control valves draw their power directly from the unit's 24V transformer and can overload and possibly burn out the transformer. Check total VA draw of the water valve(s) and ensure it is under 40 VA.

Discharge water from a heat pump can be disposed of in various ways depending on local building codes (i.e. recharge well, storm sewer, drain field, adjacent stream or pond, etc.). Most local codes restrict the use of sanitary sewer for disposal. Consult your local building and zoning departments to ensure compliance in your area.

Multiple Units on One Flow Center

NOTE: This feature is only available in the Aurora Advanced Control package (AXB board), NOT the Aurora Base Control (ABC).

When two units are connected to one loop pumping system, pump control is automatically achieved by connecting the SL terminals on connector P2 in both units with 2-wire thermostat wire. These terminals are polarity dependant (see Figure 2b). The loop pump(s) may be powered from either unit, whichever is more convenient. If either unit calls, the loop pump(s) will automatically start. The use of two units on one flow center is generally limited to a total of 20 gpm capacity.

NOTE: To achieve this same feature when heat pumps have only the Aurora Base Control, follow Figure 2a. Installer will be required to supply fuses, two relays, and wiring.

Variable Speed Pump Setup

When using a variable speed pump flow center (FCV type) the use of an AID Tool will be necessary to adjust minimum and maximum flow rates. The factory default is: minimum=50% and maximum=100% speed levels. See the 7 Series Variable Speed Pump Setup and Modulating Water Valve Setup instructions within the Unit Startup section which is located in the back of this manual. Always ensure that there is adequate flow for the heat pump. See Recommended Minimum/Maximum Flow Rates table.

NOTE: When sharing a flow center, the variable speed heat pump should be the primary unit. When two variable speed heat pumps share a flow center, the larger capacity heat pump should be the primary unit.

Typical Closed Loop Earth Coupled Installation

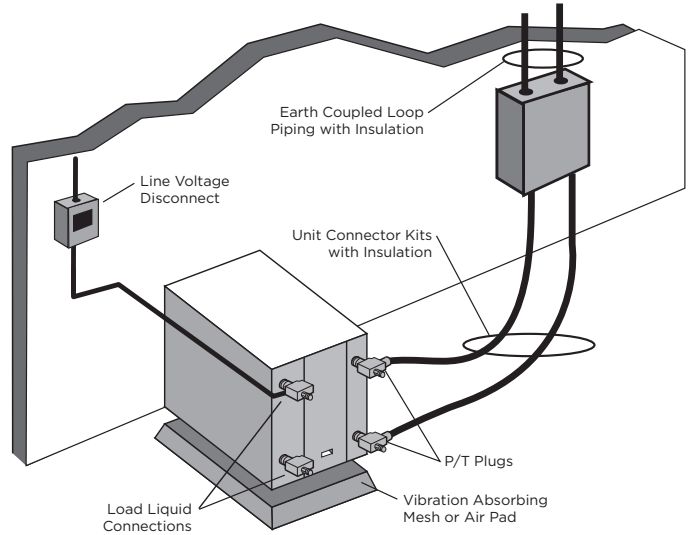

Figure 2a: Primary/Secondary Wiring with Aurora Base Control (no AXB Board)

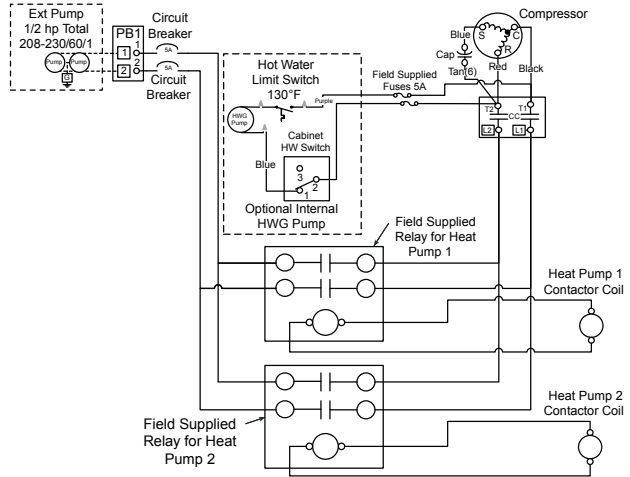
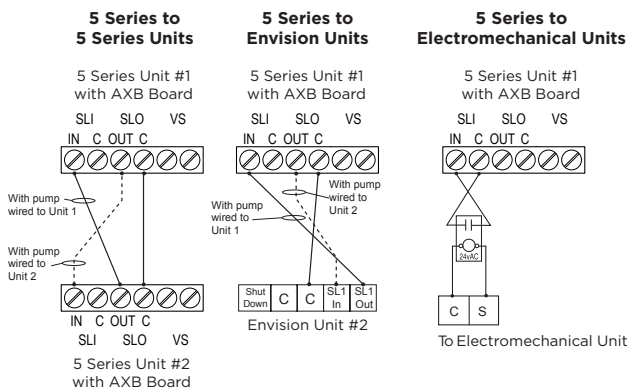

Figure 2b: Primary/Secondary Hook-up



Potable Water Systems

Hot Water Generator Connections

The heat reclaiming hot water generator coil available on the 040-075 is vented double-wall copper construction and is suitable for potable water. To maximize the benefits of the hot water generator a minimum 50-gallon water heater is recommended. For higher demand applications, use an 80-gallon water heater as shown below or two 50-gallon water heaters connected in a series. A geo storage tank should not be used in this application unless it is plumbed in a series with an electric water heater. The geo storage tank is equipped with a single 4500 Watt element and will not be able to provide adequate water heating if used as a standalone water heater. Electric water heaters are recommended. Make sure all local electrical and plumbing codes are met for installing a hot water generator. The unit is not supplied with an internal circulator. A DPK5 kit will need to be purchased to connect to the hot water generator. The DPK5 kit is supplied with installation instructions, circulator, tank adaptor and temperature limit switch. Be sure to burp (vent) the pump. Open the screw 2 turns only in the end of the pump motor (if Grundfos® pumps are used) to allow trapped air to be discharged and to ensure the motor housing has been flooded.

Suggested Domestic Water Heater Hookup

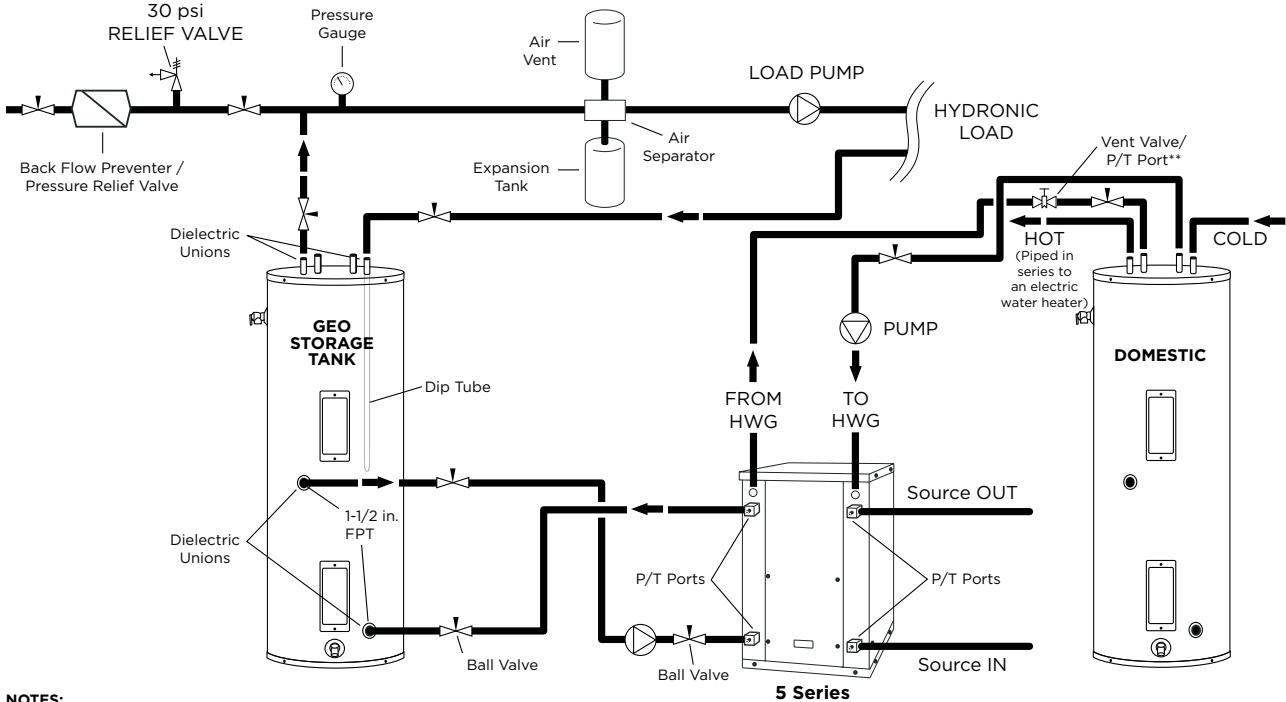

- NOTES:**
- * A 30 psi pressure relief valve (Part No: SRV30) should be used in hydronic applications.
 - ** Vent valve or P/T port at highest point in return line prior to ball valve.

Electrical Information

Fixed Speed Flow Center

The pump(s) will be connected to the terminals on PB1 in the unit electrical box as shown in Figure 3a. The pumps will automatically be cycled as required by the unit or by a signal from another unit sharing the flow center (See Figures 5 and 6). Pumps are protected by circuit breakers (CB) shown in Figure 3a.

Figure 3a: Single/Dual Cap Unit Wiring for Loop Pumps

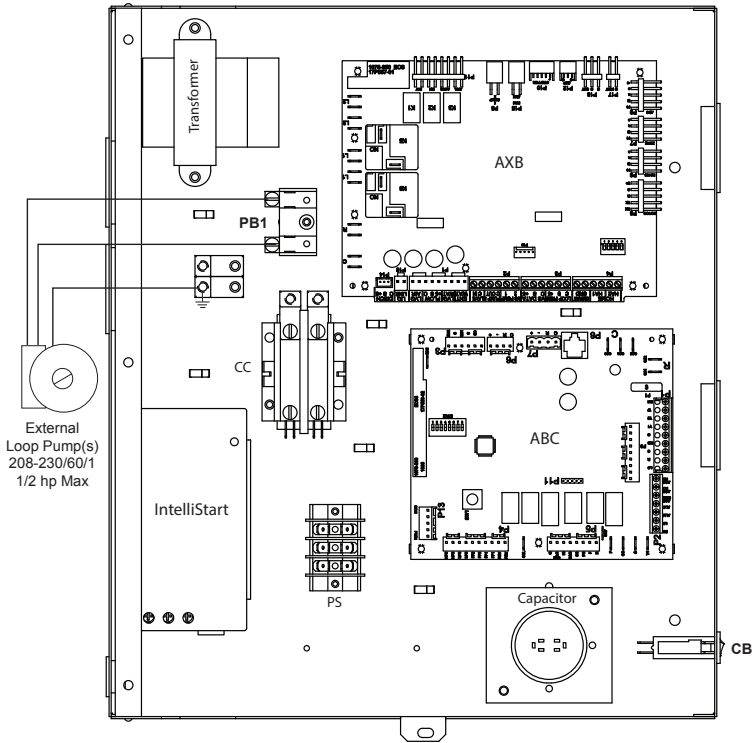

NOTES: For closed loop systems with antifreeze protection, set SW2 DIP Switch #1 to the "Loop" position on units with the Aurora control and SW2-2 should be set to "Loop" on the Premier control.

Figure 3c: FCM and FCL Flow Center Wiring (Not Referenced)

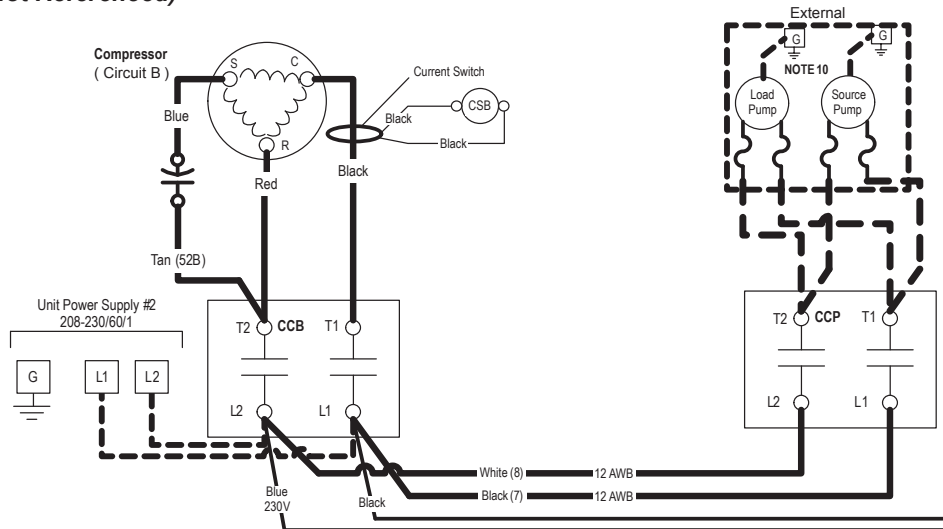

NOTES: FCM and FCL Flow Centers must be wired to a separate contactor (20 amp minimum). The HydroZone Accessory Control Box works best for this application.

Electrical Information cont.

Variable Speed Flow Center

Single Pump Variable Speed Flow Center

If a variable speed single pump flow center is used, the flow center will come with two red and one green wires for the high voltage wiring. The variable speed pump **MUST** be powered at all times and therefore **MUST** be wired to the "L" side of electrical system or damage to the pump will occur (pump cannot be powered from "T" side of compressor contactor). Connect the red HIGH VOLTAGE wires to L1 and L2 on the AXB, connect the green GROUND wire to the ground lug, as shown in figure 4a. Follow all electrical and local codes for wiring.

The variable speed UPMXL 25-124 pump also requires a low voltage signal to operate properly, if the low voltage signal isn't present the pump will run at 100%. Route the low voltage harness connected to the pump to the AXB screw terminals on P2 and P3 connectors per diagram 4b.

Both the low and high voltage harnesses are labeled. The pump will be automatically cycled as required either by the unit or by a signal from another unit sharing the same flow center. Pumps are protected by circuit breakers as shown on the unit schematic.

Figure 4a: Single VS Pump High Voltage Wiring

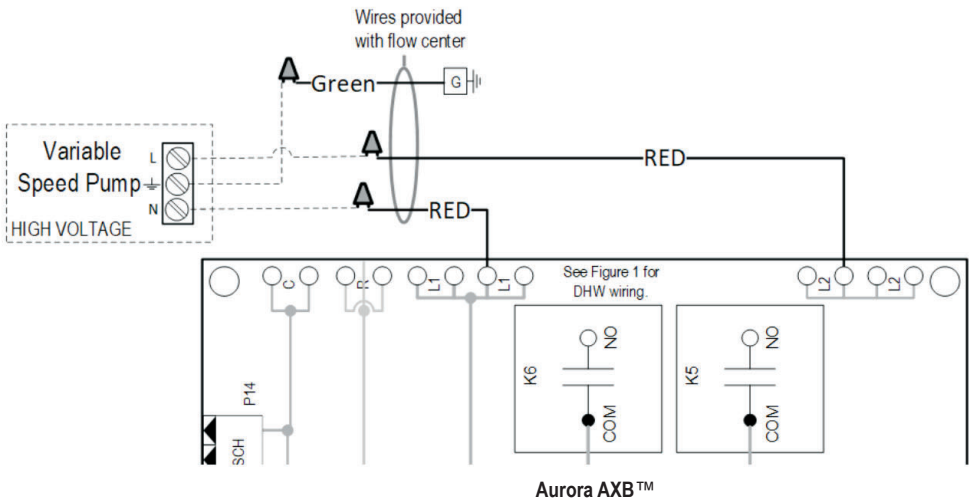
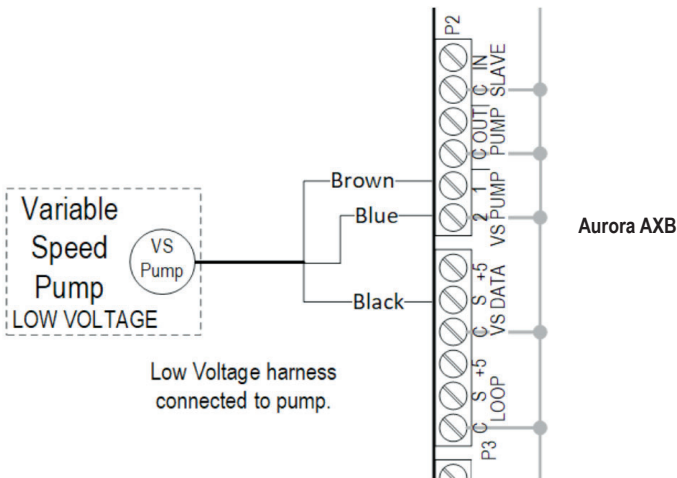

Figure 4b: Single VS Pump Low Voltage Wiring



Note: Aurora AXB must be used to control the UPMXL 25-124 pump.

Electrical Information cont.

Variable Speed Flow Center cont.

Two Pump Variable Speed Flow Center

If a variable speed two pump flow center is used, the flow center will come with four red and two green wires for the high voltage wiring. The second set of (2) red and (1) green wires is provided for installation flexibility. The variable speed pump **MUST** be powered at all times and therefore **MUST** be wired to the “L” side of electrical system or damage to the pump will occur (pump cannot be powered from “T” side of compressor contactor). The UPMXL 25-124 pump has screw terminals for the high voltage connection. Connect the red HIGH VOLTAGE wires to L1 and L2 on the AXB, connect the green GROUND wire to the ground lug, as shown in figure 4d. Follow all electrical and local codes for wiring.

The variable speed UPMXL 25-124 pump also requires a low voltage signal to operate properly, if the low voltage signal isn't present the pump will run at 100%. Route the low voltage harness connected to the right hand pump to the AXB screw terminals on P2 and P3 connectors. Route the low voltage harness connected to the left hand pump to the AXB screw terminals on P2 and P3 connector per figure 4c. The black wire on the left hand pump will have a label on it that reads **“DO NOT CONNECT THIS WIRE. ONLY ONE VS PUMP FEEDBACK SIGNAL CAN BE CONNECTED TO AXB BOARD”**.

Both the low and high voltage harnesses are labeled. The pump will be automatically cycled as required either by the unit or by a signal from another unit sharing the same flow center. Pumps are protected by circuit breakers as shown on the unit schematic.

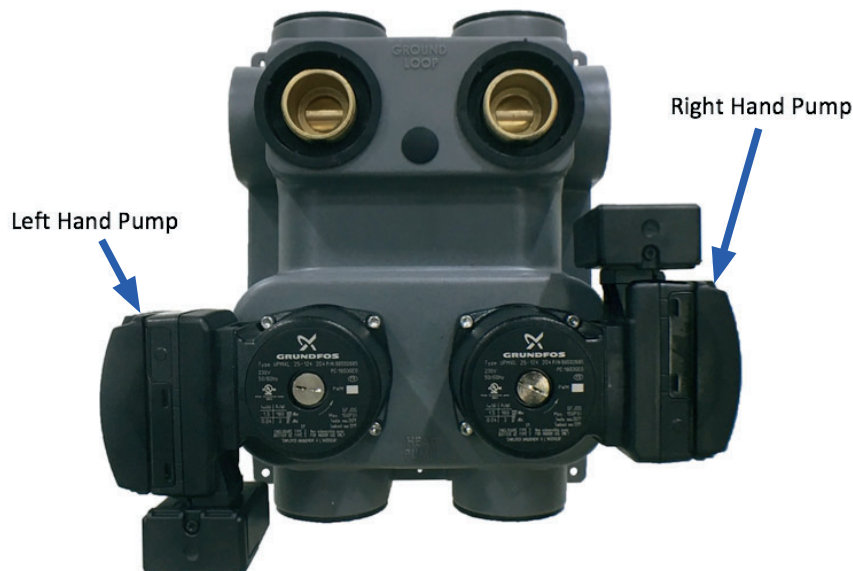

NOTE: Both pumps will speed up and slow down together.

Electrical Information cont.

Variable Speed Units cont.

Two Pump Variable Speed Flow Center cont.

The use of the black wire on the left hand pump is ONLY to be connected for troubleshooting of the pumps. The left hand pump will have a closed end splice connector crimped to the black wire. Cut the closed end splice connector off and strip the wire. During troubleshooting remove the black wire from the right hand pump from the AXB P3 VS DATA S screw terminal and connect the black wire from the left hand pump to the same location. After the troubleshooting is complete remove the black wire from the left hand pump and connect the black wire from the right hand pump.

Place electrical tape or wire nut on the left hand pump black wire. The two pump variable speed flow center cannot have each UPMXL 25-124 pump wired to two separate heat pumps otherwise damage to the pumps will occur (unless it's an NPD Series flow center).

Figure 4c: Two VS Pump Low Voltage Wiring

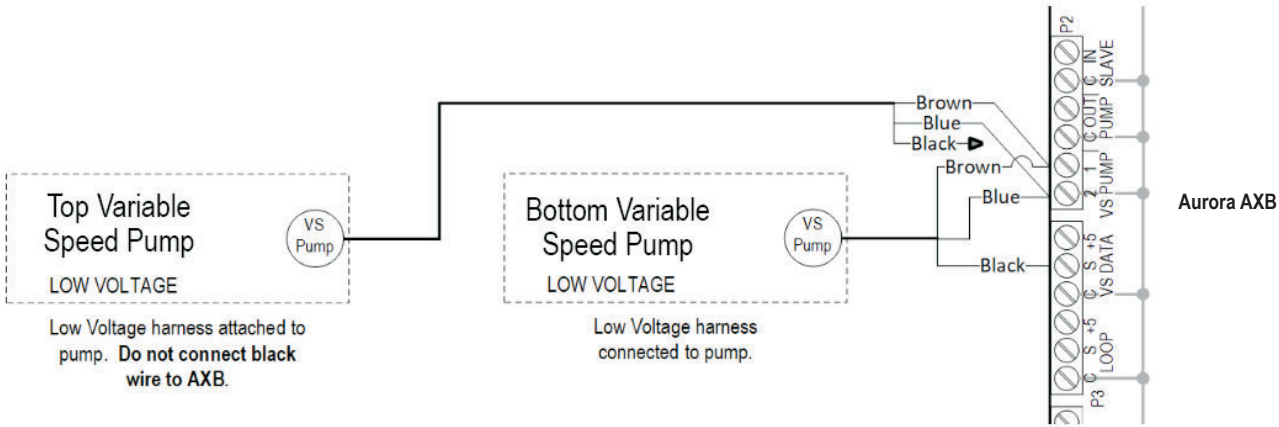

Note: Aurora AXB must be used to control the UPMXL 25-124 pump.

Figure 4d: Two VS Pump High Voltage Wiring

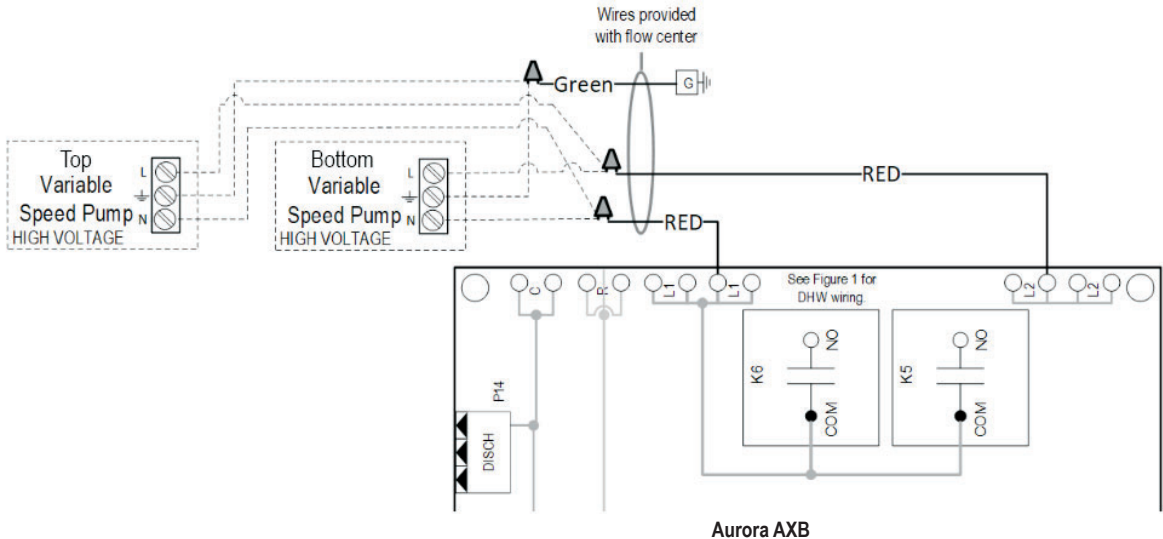

Potable Water Systems cont.

The O18 and O25 models can be equipped to provide domestic hot water generation.

Alternate Hot Water Installation with Direct Coupling to a Double Wall Unit

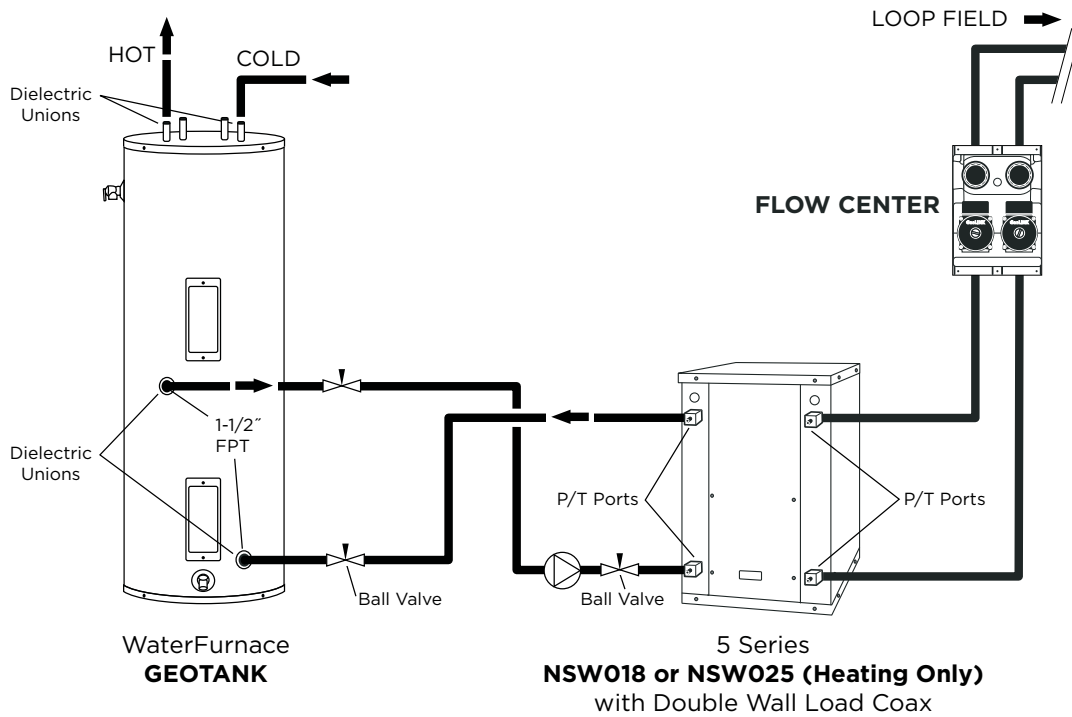

NOTES:

- 1) Unions and valves must be installed so that acid flushing of the heat exchanger is possible.
- 2) Make sure there is not a check valve in the diptube of the tank.

Hydronic Section

General guidelines are shown below for component selection and design/installation criteria for the piping system. Local codes supersede any recommendations in this manual.

Shut Off/Flow Regulation Valves

Use full port ball valves or gate valves for component isolation. If valves are going to be used frequently, ball valves are recommended. Globe valves are designed for flow regulation. Always install globe valves in the correct direction (fluid should enter through the lower body chamber).

Check valves

Swing check valves must be installed in the horizontal position with the bonnet of the valve upright. Spring check valves can be mounted in any position. A flow check valve is required to prevent thermo-siphoning (or gravity flow) when the circulator pump is off or when there are two circulators on the same system.

Storage (Buffer) Tank

A buffer tank is required for all hydronic heating systems using 5 Series heat pumps. The tank should be sized to provide 2 gallons of storage capacity for every one thousand Btuh's of nominal heat pump capacity.

Pressure Relief Valve

Most codes require the use of a pressure relief valve if a closed loop heat source can be isolated by valves. Even if local code does not require this device, WaterFurnace recommends its installation. If the pressure relief valve in the buffer tank is not already rated at 30 psi (207 kPa) maximum pressure, one must be installed. The pressure relief valve should be tested at start up for operation. Note that the waste pipe must be at least the same diameter as the valve outlet (never reduce), and valves may not be added to this pipe. The bottom of the pipe must terminate at least 6" (15 cm) above the floor. If the piping is connected to a drain, there must be an air gap.

Backflow Prevention Check Valves

Most codes require backflow prevention check valves. Note that a single check valve is not equal to a backflow prevention check valve. Even if local code does not require this device, WaterFurnace recommends its installation. This is particularly important if the system will use antifreeze.

Pressure Reducing Valves or Feed Water Valves

This valve lowers the pressure from the make-up water line to the system. Most are adjustable and directional. A "fast fill" valve is required for initial filling of the system. Some have screens, which must be cleaned after the initial filling. If there is a restriction in the screen, the system could go to 0 psi (0 kPa), potentially causing pumps(s) failure. A valve should be installed on each side of the pressure reducing valve for servicing. Both valves should have tags reading "Do not shut this valve under normal operation - service valve only."

Expansion Tanks

Expansion tanks are required on hydronic systems to help absorb the pressure swings as the temperature in the system fluctuates.

Elbows/Tees

Long radius elbows or two 45° elbows will lower pressure drop. Standard tees have a greater restriction on the "T" portion than tees designed with angled outlet ports.

Antifreeze

Antifreeze is required if any of the piping system is located in areas subject to freezing.

Dielectric Unions

Dielectric unions are recommended whenever connecting two dissimilar metals to one and other to prevent electro-galvanic corrosion.

When using the various types of hydronic heat distribution systems, the temperature limits of the geothermal system must be a major consideration. In new construction, the distribution system can easily be designed with the temperature limits in mind. In retrofits, care must be taken to address the operating temperature limits of the existing distribution system. The maximum storage tank temperature for the 5 Series 500W11 is 130°F (54.4°C). Typical in floor radiant systems require much lower temperatures, typically 100°-115°F, which is ideal for the 5 Series NSW.

Hydronic Section cont.

If using a Geothermal Storage tank there will be two red wires exiting out of the top of the tank. These red wires extend internally down to the thermistor/tank thermostat section of the tank. Remove the bottom tank cover to expose the red wires as well as the yellow tank thermistor wires.

HydroZone

If using HydroZone control, connect the two red wires to the two yellow wires using wire nuts. Next, connect the two red wires from the top of the Geothermal Storage tank to "TS" and "GND" on the HydroZone. The "OAT" and "GND" terminals on the HydroZone are used for an outdoor air sensor.

HydroStat

If using HydroStat control, connect the two red wires to the yellow wires using wire nuts. Next, connect the two red wires from the top of the Geothermal Storage tank to "TS" and "GND" on the HydroStat. The "OAT" and "GND" terminals on the HydroStat are used to connect the controller to the ELWT (Entering Load Water Temperature) well point sensor. This sensor is located on the load side entering water line inside the unit.

For other field installed controllers, these two red wires will need wired to the appropriate sensor input terminals. Another option for connection is to connect the thermostat on the Geothermal Storage tank directly to "R" and "Y1" on the ABC board.

Adequate rate of flow (GPM) is very important to system performance and long term reliability. Follow the guidelines for recommended flow in the recommendations table.

Geothermal Storage Tank Thermostat and Thermistor

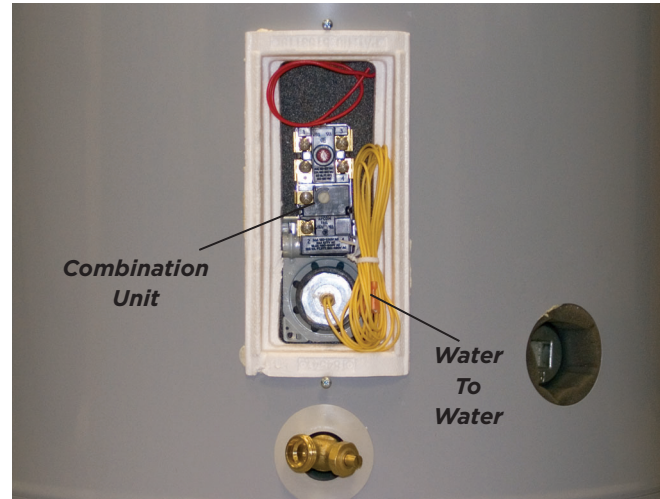

Thermistor Wires Connected to TS and GND on HydroZone Controller.

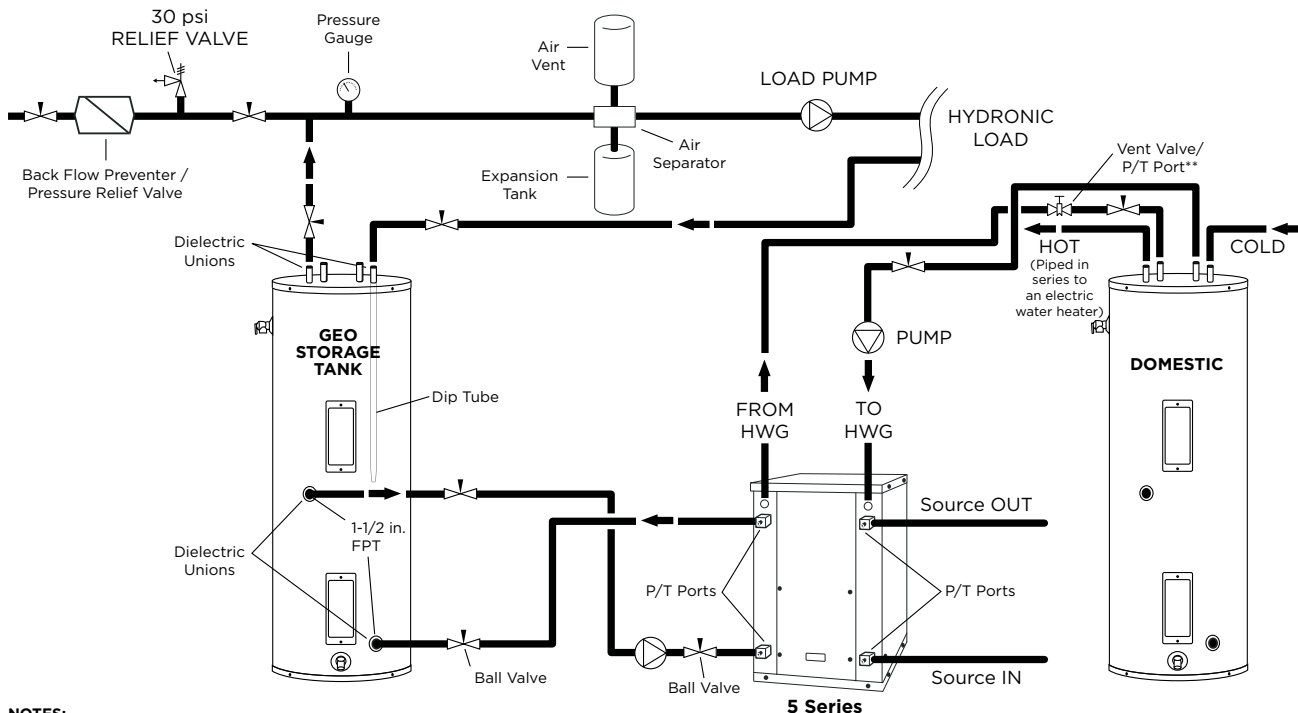

NOTES:
 * A 30 psi pressure relief valve (Part No: SRV30) should be used in hydronic applications.
 ** Vent valve or P/T port at highest point in return line prior to ball valve.

Accessories and Options

Earth Loop Pump Kit (Field Installed)

A specially designed one or two-pump module provides all liquid flow, fill and connection requirements for independent single unit systems (230/60/1 only). The one-pump module is capable of 20 feet of head at 16.0 GPM, while the two-pump module is capable of 40 feet of head at 16.0 GPM.

Hot Water Generator (Factory Installed, 040, 050, 060, and 075 Only)

An optional heat reclaiming hot water generator coil constructed of vented double-wall copper construction suitable for potable water is available. The coil is factory mounted inside the cabinet. A DPK5 pump kit is required (field installed), which includes a HWG tank connection and a temperature limit pump shutoff.

Load-side Pump Kit (Field Installed)

Four (4) load pump kits are available to provide all liquid flow requirements for independent single unit systems (230/60/1 only). WaterFurnace part number **24S516-10** (Grundfos UPS15-42RU) is a composite body pump. **EWPK2** (Grundfos UP26-64BF) is a bronze body pump. Bronze or composite body pumps should be used when water conditions exist that are not compatible with cast iron or for applications such as domestic water heating. WaterFurnace part number EWPK1 (1" FPT flange) and EWPK3 (1 1/4" FPT flange) come with a cast iron body pump (Grundfos UP26-99F) that can be used for hydronic heating applications.

Calculate the system pressure drop then refer to the pump curves to select the proper pump. All four of the WaterFurnace pump kits can be used for hydronic heating applications as long as they meet the flow requirements. If the flow requirements are outside the pump curve, an alternate pump will need to be obtained to maintain the necessary flow.

IntelliStart®

The optional IntelliStart single phase soft starter will reduce the normal start current (LRA) by 60-70%. This allows the heat pump to go off-grid. Using IntelliStart also provides a substantial reduction in light flicker, reduces start-up noise, and improves the compressor's start behavior. IntelliStart is available in a field retrofit kit (WaterFurnace part number **IS60RKL** or **IS60RKS**) or as a factory installed option.

Water Connection Kits (Field Installed)

Water connection kits are available to facilitate loop side and load side water connections.

- **MA4FPT** - Forged brass 1" MPT x 1" FPT square street elbow with P/T plug for 018-040 water side connections
- **MA5FPT** - Forged brass 1.25" MPT x 1.25" FPT square street elbow with P/T plug for 050-075 water side connections
- **WFI-HKM-125-24-MO** - 1 inch x 24 inch stainless steel braided hose kit
- **WFI-HKM-100-24-MO** - 1 1/4 inch x 24 inch stainless steel braided hose kit

UPS15-42RU Three-Speed Pump Curve

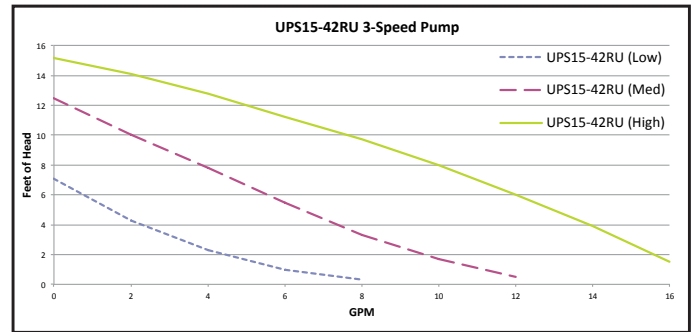

UP26-64BF and UP26-99F Single and Two Pump Curve

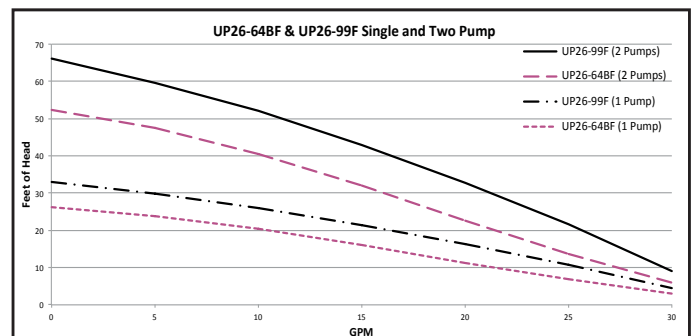

NOTE: Never use piping smaller than 1 inch. Limit length of pipe to 50 feet or less.

Type L Copper Pressure Loss Ft of Hd per 100 ft

GPM	Type L Copper Tube				
	3/4	1	1-1/4	1-1/2	2
2	1.5				
3	3.2				
4	5.5	1.4			
5	8.5	2.1			
6		2.9	1.1		
7		3.9	1.4		
8		5.0	1.8		
9		6.1	2.3	0.9	
10		7.5	2.8	1.1	
12			3.9	1.6	
14			5.2	2.1	
16			6.6	2.7	
18			8.2	3.4	
20			10.0	4.1	1.1
22				5.0	1.3
25				6.3	1.6
30					2.2
35					2.9
40					3.8
45					4.7
50					5.7

NOTE: Standard piping practice limits pressure drop to 4 feet of hd per 100 feet in 2 inch and larger pipe.

Accessories and Options cont.

Geo Storage Tank Dimensions

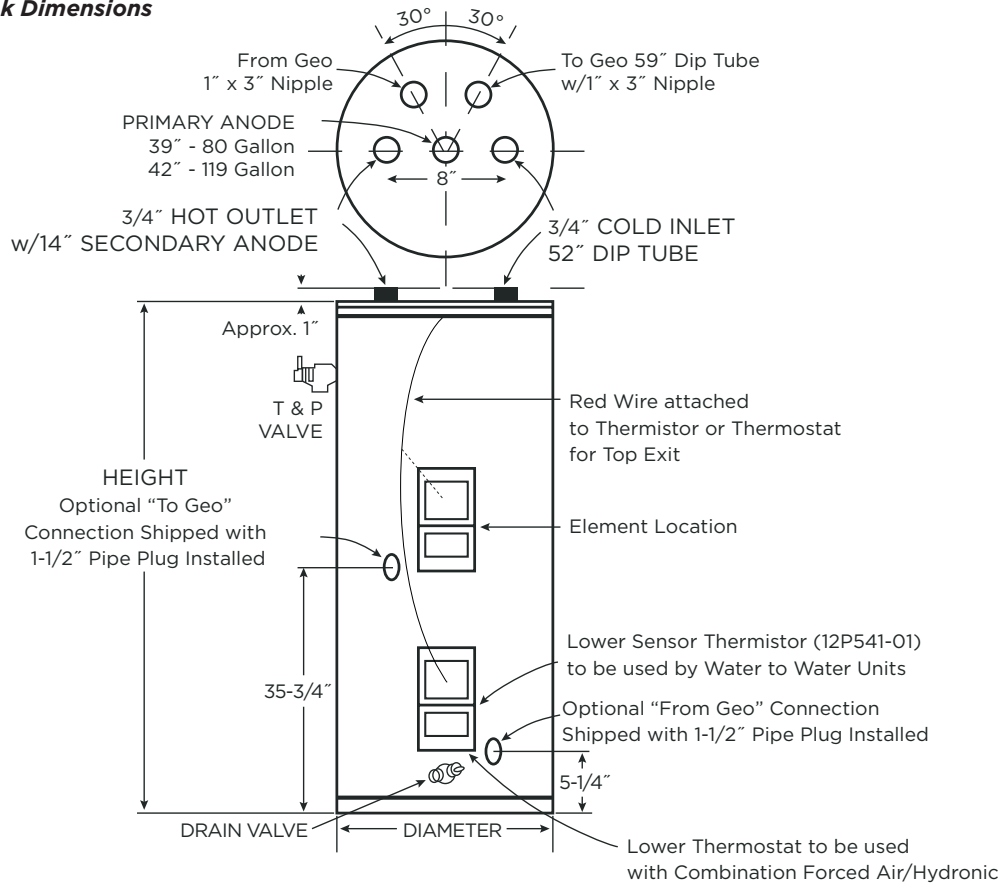

MODEL NUMBER	GALLON CAPACITY	ELEMENT WATTAGE (240 VOLT)	NUMBER OF ELEMENTS	R VALUE	DIMENSIONS IN INCHES		APPROX. SHIPPING WEIGHT (lbs.)
					HEIGHT	DIAMETER	
GEO-STORAGE-80	80	4500	1	16	63-1/4	24	204
GEO-STORAGE-120	119	4500	1	16	63-1/4	28	311

Electrical Data

Unit Model	Rated Voltage	Voltage Min/Max	Compressor			Load Pump	Source Pump	Total Unit FLA	Min Ckt Amp	Maximum Fuse/HACR
			RLA	LRA	LRA*					
018	208-230/60/1	187/253	9.0	48.0	17.0	1.8	5.4	16.2	18.5	25
025	208-230/60/1	197/253	14.1	73.0	25.5	1.8	5.4	21.3	24.8	35
040	208-230/60/1	187/253	20.0	115.0	40.3	1.8	5.4	27.2	32.2	50
050	208-230/60/1	187/253	26.4	134.0	46.9	1.8	5.4	33.6	40.2	60
060	208-230/60/1	187/253	28.3	178.0	62.3	1.8	5.4	35.5	42.6	70
075	208-230/60/1	187/253	26.9	145.0	50.8	1.8	5.4	34.1	40.8	60

Notes: All fuses type "D" time delay (or HACR circuit breaker in USA).
 Source pump amps shown are for up to a 1/2 HP pump
 Load pump amps shown are for small circulators.
 *With optional IntelliStart

10/27/2021

Electrical Data cont.

Control Box

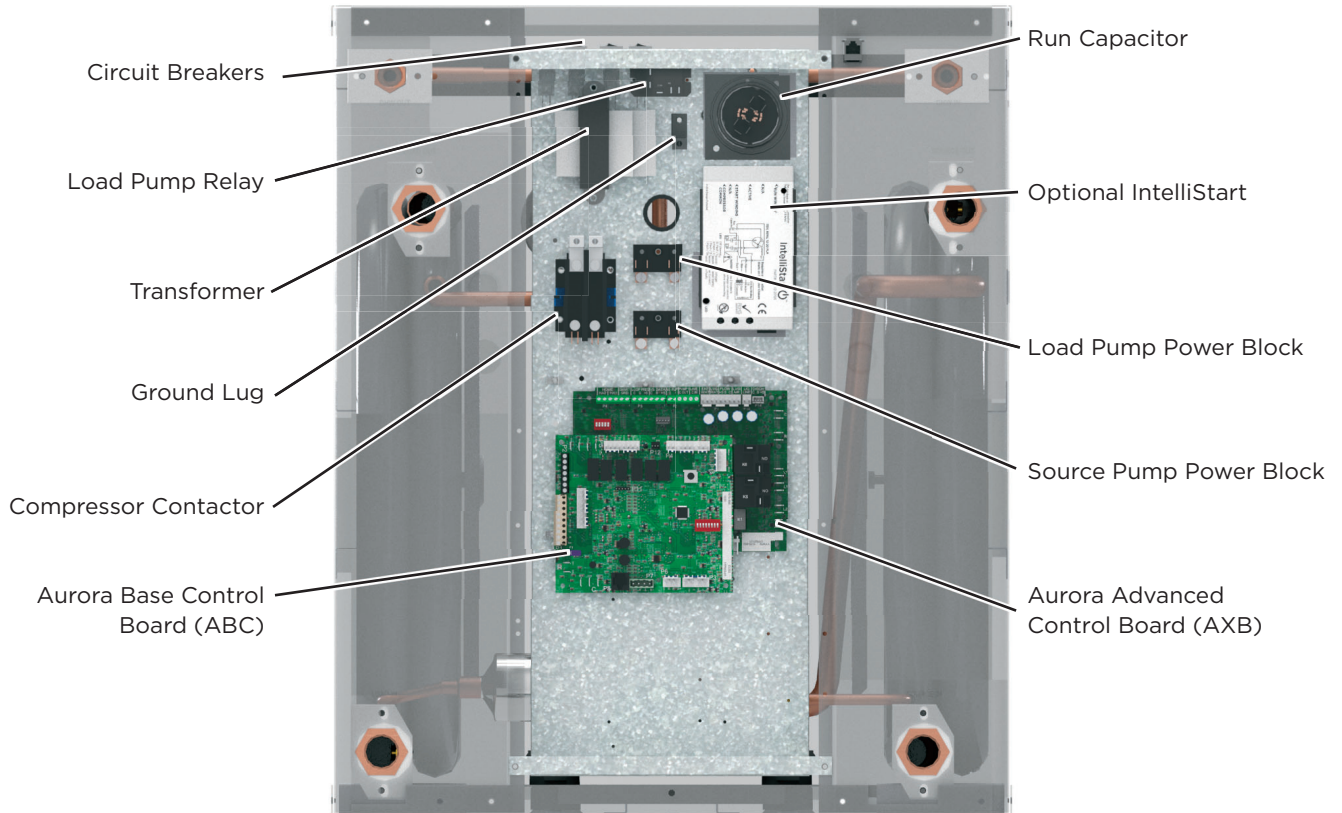

Electrical Data cont.

208 Volt Operation

All 208-230 volt units are factory wired for 230 volt operation. To convert the unit from a 230V unit to a 208V unit follow these steps:

1. Remove the blue transformer wire from terminal L2 on the compressor contactor and secure the wire taking care to insulate the end with electrical tape.
2. Locate the red transformer wire and connect it to the L2 terminal of the compressor contactor.

Electrical

Be sure the available power is the same voltage and phase as that shown on the unit serial plate. Line and low voltage wiring must be done in accordance with local codes or the National Electric Code, whichever is applicable. Refer to the Electrical Data table for wire and fuse or circuit breaker sizing information.

Flow Center Pump Connection (208-230/60/1)

Two circuit breaker protected internal terminal block connections with 1/4-inch spade connectors are provided; one for the load pump and one for the source pump. The fixed speed source pump directly connects to the PB2 terminal block for the source pump (see Figure 5). The load pump directly connects to the PB1 terminal block for the load pump.

Accessory Relay

A set of “dry” contacts has been provided to control accessory devices, such as water solenoid valves on open loop installations, electronic air cleaners, humidifiers, etc. This relay contact should be used only with 24 volt signals and not line voltage power. The relay has both normally open and normally closed contacts and can operate with either the fan or the compressor. Use DIP switch SW2-4 and 5 to cycle the relay with blower, compressor, or control a slow opening water valve. The relay contacts are available on terminals #1 and #3 for normally closed, and #2 and #3 for normally open on P2.

A second configurable accessory relay is provided on the AXB board, if installed. When powering high VA draw components such as electronic air cleaners or V type open loop water valves, R should be taken ‘pre-fuse’ from the ‘R’ quick connect on the ABC board and not the ‘post-fuse’ ‘R’ terminal on the thermostat connection. If not, blown ABC fuses might result.

Control Box Relocation

The control box can be installed on the rear of the unit. To relocate the control box, follow the procedures below.

1. Remove all power sources to the unit.
2. Remove the unit’s top panel.
3. Cut all plastic wire ties to the following:
 - a) High pressure switch (black wires)
 - b) Low pressure switch (blue wires)
 - c) Freeze sensing and Thermistors
 - d) Compressor wires
4. Remove the four screws from the control box.
5. Relocate the control box to opposite end of the unit.
6. Using the screws removed in step 4 above, reattach the control box.
7. Move the RS485 Keystone Coupler to the opening on the back side of the unit.
8. Secure all wires so they do not come in contact with refrigerant lines.
9. Replace the top of the unit.
10. Replace both access panels.
11. Reapply power sources.

Figure 5: Source Pump Wiring 208-230/60/1

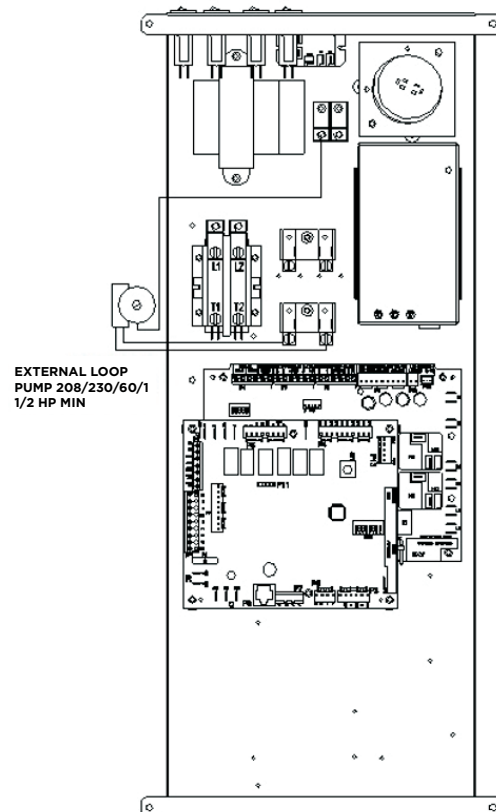

Wiring Schematics

Aurora Control - 208-230/60/1

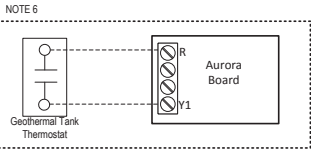
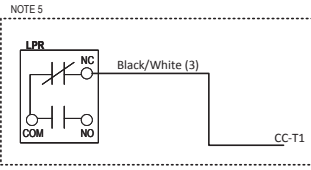
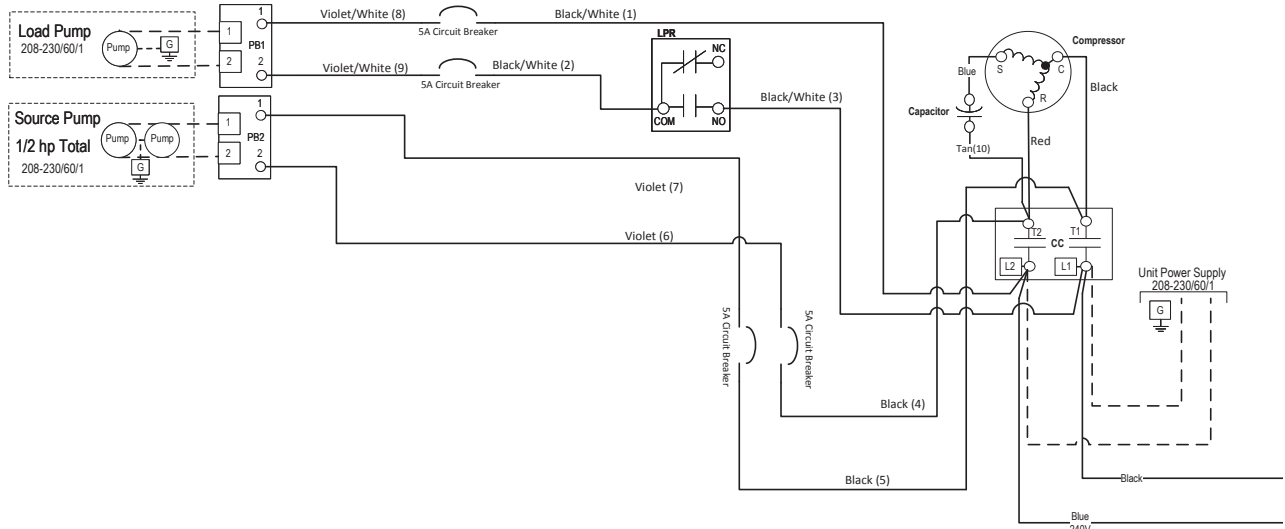

Aurora LED Flash Codes		
Slow Flash	1 second on and 1 second off	
Fast Flash	100 milliseconds on and 100 milliseconds off	
Flash Code	100 milliseconds on and 400 milliseconds off with a 2 second pause before repeating	
Random Start Delay (Alternating Colors)		Configuration LED (LED2, Yellow)
Status LED (LED1, Green)	Fast Flash	No Software Override
Configuration LED (LED2, Yellow)	Fast Flash	DIP Switch Override
Fault LED (LED3, Red)	Fast Flash	Slow Flash
Fault LED (LED1, Red)		Status LED (LED3, Green)
Normal Mode	OFF	Normal Mode
Input Fault Lockout	Flash Code 1	Control is Non-Functional
High Pressure Lockout	Flash Code 2	Test Mode
Low Pressure Lockout	Flash Code 3	Lockout Active
Future Use	Flash Code 4	Dehumidification Mode
Freeze Detection - FP1	Flash Code 5	Future Use
Reserved	Flash Code 6	Future Use
Condensate Overflow Lockout	Flash Code 7	Load Shed
Over/Under Voltage Shutdown	Flash Code 8	ESD
Future Use	Flash Code 9	Future Use
Future Use	Flash Code 10	Flash Code 7
FP1 and FP2 Sensor Error	Flash Code 11	

Notes

- 1 - Switch blue and red wires for 208V operation.
- 2 - HydroZone controller is an optional field installed accessory.
- 3 - Reversing Valve wires not installed on heating only option.
- 4 - FP2 is replaced with a resistor on heating only option.
- 5 - Move black/white(3) wire when HydroZone or HydroStat is not used for pump control to LPR-NC and CC-T1.
- 6 - When Geothermal Storage Tank is wired directly to the Aurora Board.
- 7 - HydroStat Communicating Controller is an optional field installed accessory.

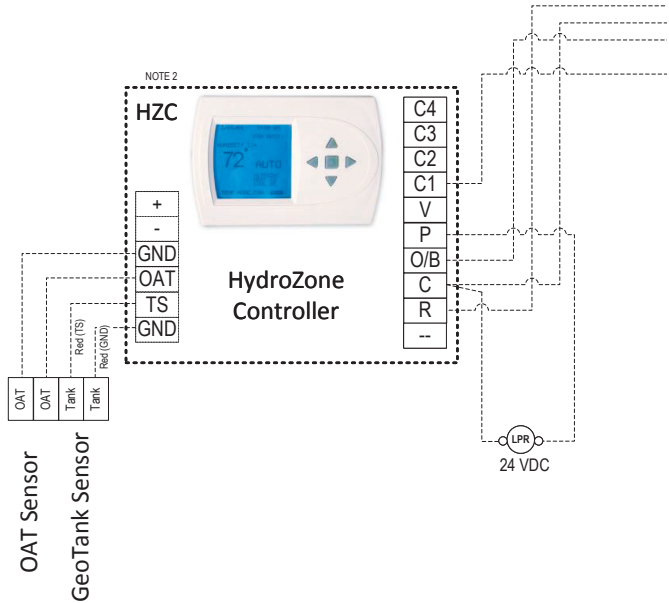

Wiring Schematics cont.

Aurora Control - 208-230/60/1

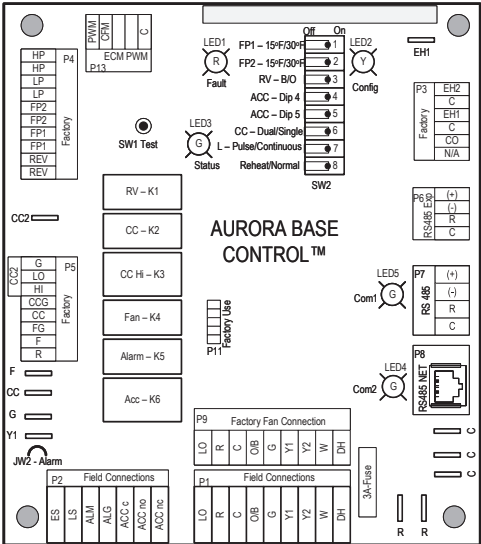
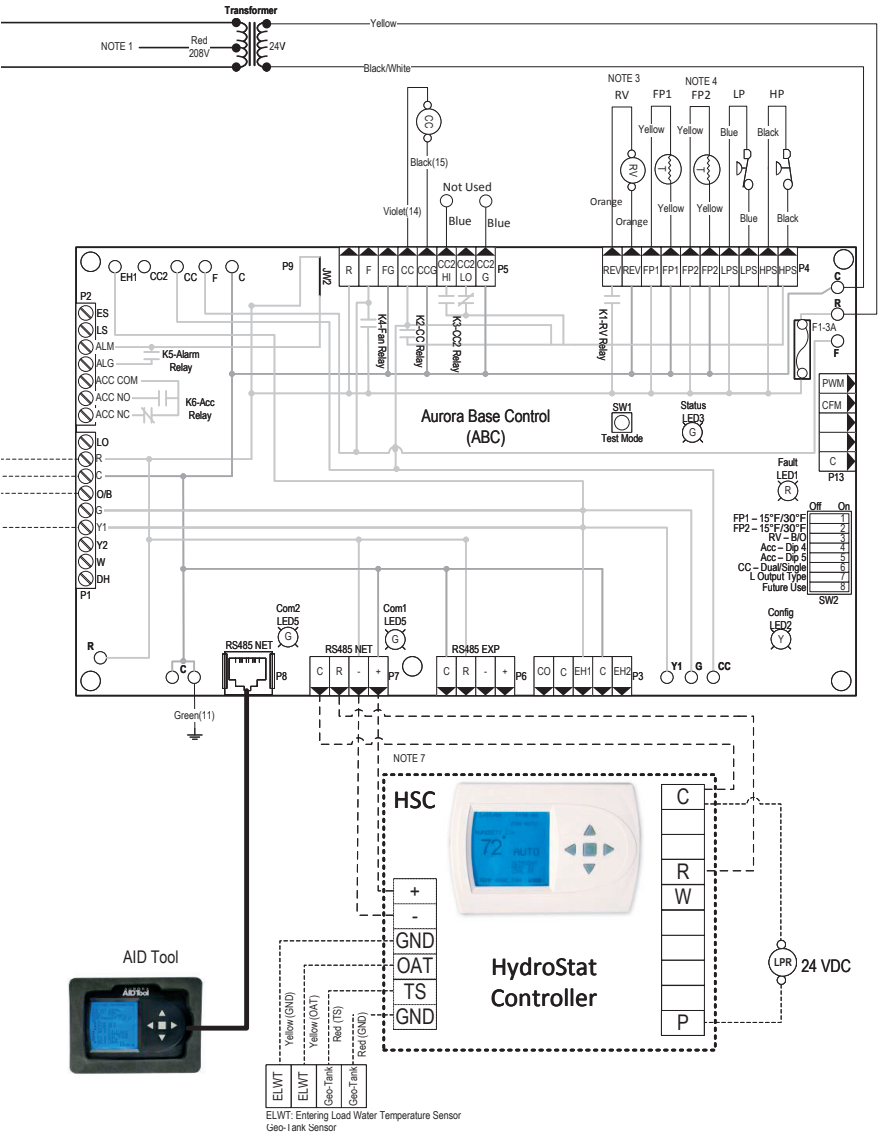
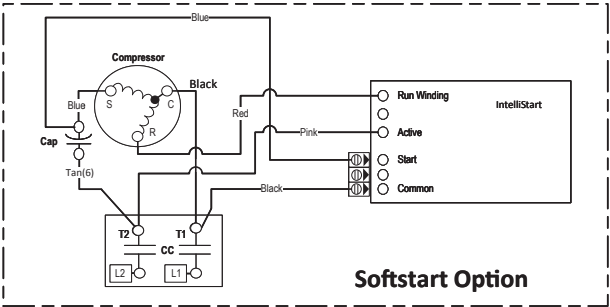

ABC SW2 Accessory Relay		
DESCRIPTION	SW2-4	SW2-5
Cycle with Blower	ON	ON
Cycle with Compressor	OFF	OFF
Water Valve Slow Opening	ON	OFF
Cycle with Comm. T-stat Hum Cmd	OFF	ON

Aurora Timing Events		
Event	Normal Mode	Test Mode
Random Start Delay	5 to 80 seconds	1 second
Compressor On Delay	5 seconds	< 1 second
Compressor Minimum On Time	2 minutes	5 seconds
Compressor Short Cycle Delay	4 minutes	15 seconds
Fault Recognition Delay - High Pressure	Less than 1 second	Less than 1 second
Start-Up Bypass - Low Pressure	2 minutes	30 seconds
Fault Recognition Delay - Low Pressure	30 seconds	30 seconds
Start-Up Bypass - Low Water Coil Limit	2 minutes	30 seconds
Fault Recognition Delay - Low Water Coil Limit	30 seconds	30 seconds
Fault Recognition Delay - Condensate Overflow	30 seconds	30 seconds
HydroZone Call Recognition Time	2 seconds	2 seconds
Water Valve Slow Open Delay	90 seconds	90 seconds

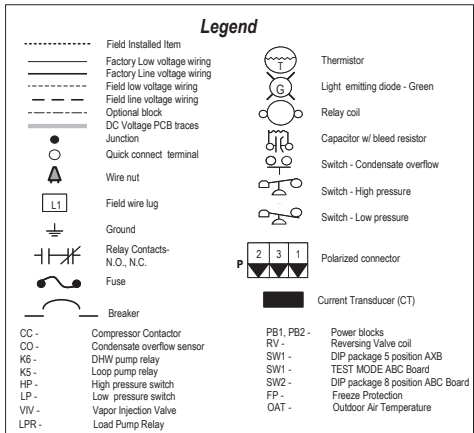

Wiring Schematics - cont.

Aurora Advanced Control - 208-230/60/1

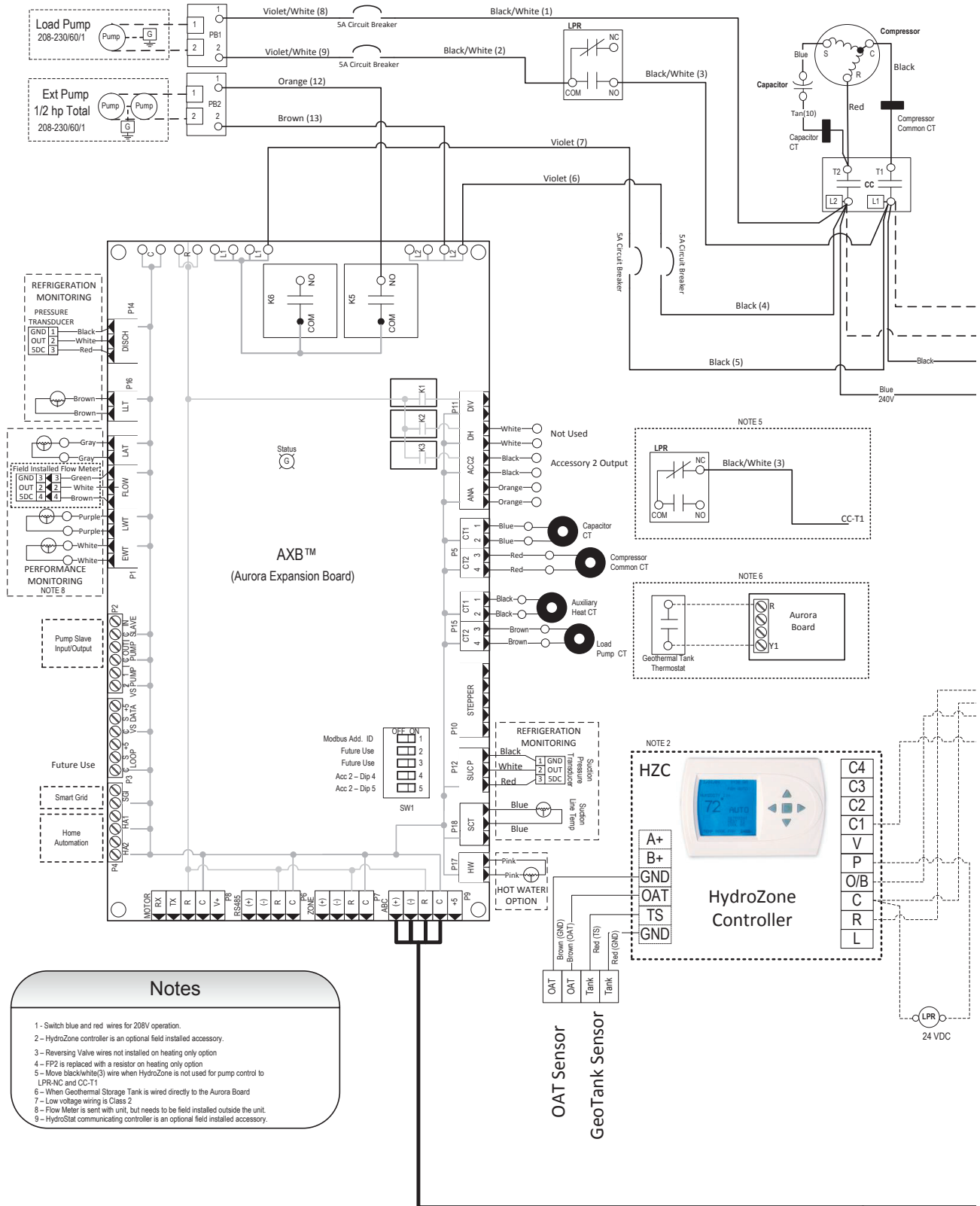

Wiring Schematics - cont.

Aurora Advanced Control - 208-230/60/1

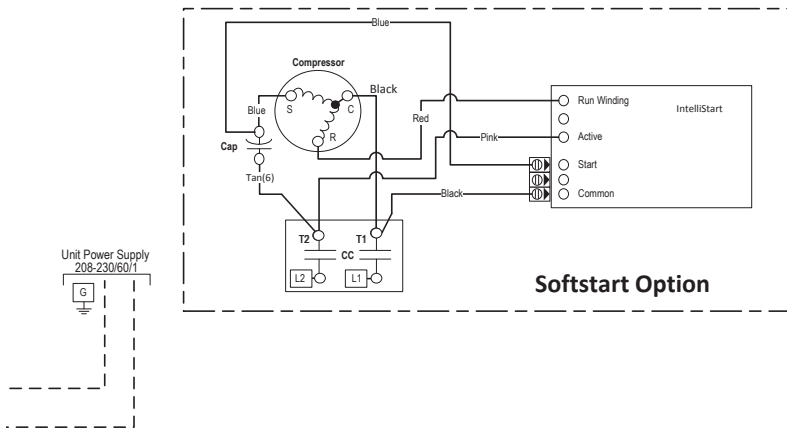

Aurora LED Flash Codes			
Slow Flash	1 second on and 1 second off		
Fast Flash	100 milliseconds on and 100 milliseconds off		
Flash Code	100 milliseconds on and 400 milliseconds off with a 2 second pause before repeating		
Random Start Delay (Alternating Colors)		Configuration LED (LED2, Yellow)	
Status LED (LED1, Green)	Fast Flash	No Software Override	OFF
Configuration LED (LED2, Yellow)	Fast Flash	DIP Switch Override	Slow Flash
Fault LED (LED3, Red)	Fast Flash		
Fault LED (LED1, Red)		Status LED (LED3, Green)	
Normal Mode	OFF	Normal Mode	ON
Input Fault Lockout	Flash Code 1	Control is Non-Functional	OFF
High Pressure Lockout	Flash Code 2	Test Mode	Slow Flash
Low Pressure Lockout	Flash Code 3	Lockout Active	Fast Flash
Future Use	Flash Code 4	Dehumidification Mode	Flash Code 2
Freeze Detection - FP1	Flash Code 5	Future Use	Flash Code 3
Reserved	Flash Code 6	Future Use	Flash Code 4
Condensate Overflow Lockout	Flash Code 7	Load Shed	Flash Code 5
Over/Under Voltage Shutdown	Flash Code 8	ESD	Flash Code 6
Future Use	Flash Code 9	Future Use	Flash Code 7
Future Use	Flash Code 10		
FP1 and FP2 Sensor Error	Flash Code 11		

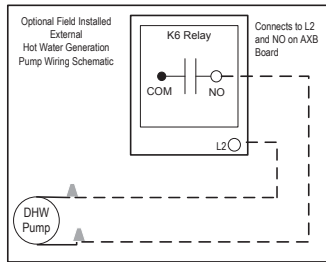
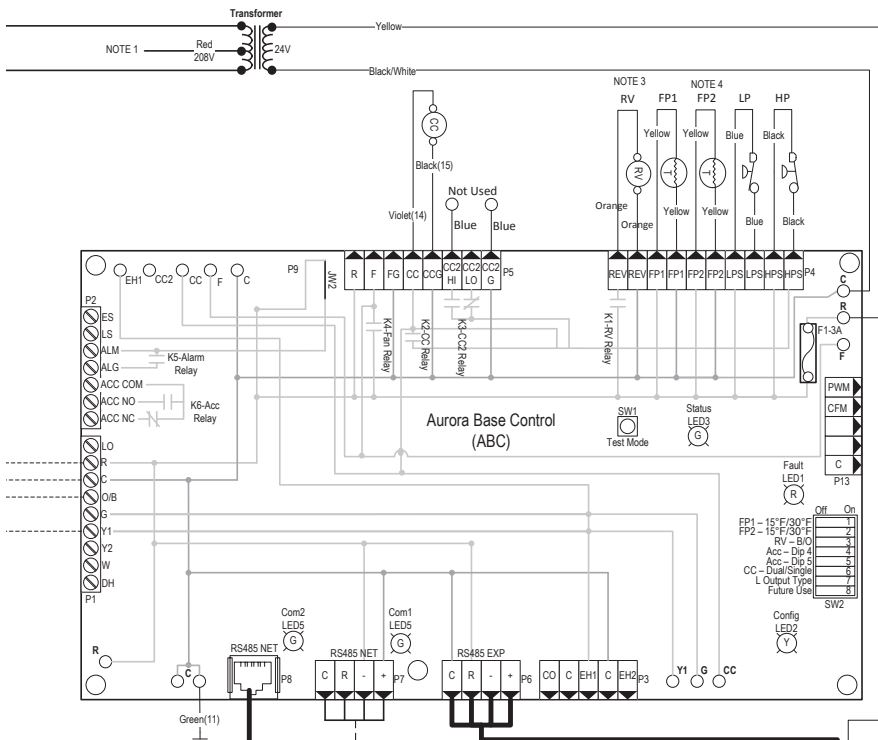

ABC SW2 Accessory Relay		
DESCRIPTION	SW2-4	SW2-5
Cycle with Blower	ON	ON
Cycle with Compressor	OFF	OFF
Water Valve Slow Opening	ON	OFF
Cycle with Comm. T-stat Hum Cmd	OFF	ON

Aurora Timing Events		
Event	Normal Mode	Test Mode
Random Start Delay	5 to 80 seconds	1 second
Compressor On Delay	5 seconds	< 1 second
Compressor Off Delay	2 minutes	5 seconds
Compressor Short Cycle Delay	4 minutes	15 seconds
Fault Recognition Delay - High Pressure	Less than 1 second	Less than 1 second
Start-Up Bypass - Low Pressure	2 minutes	30 seconds
Fault Recognition Delay - Low Pressure	30 seconds	30 seconds
Start-Up Bypass - Low Water Coil Limit	2 minutes	30 seconds
Fault Recognition Delay - Low Water Coil Limit	30 seconds	30 seconds
Fault Recognition Delay - Condensate Overflow	30 seconds	30 seconds
HydroZone Call Recognition Time	2 seconds	2 seconds

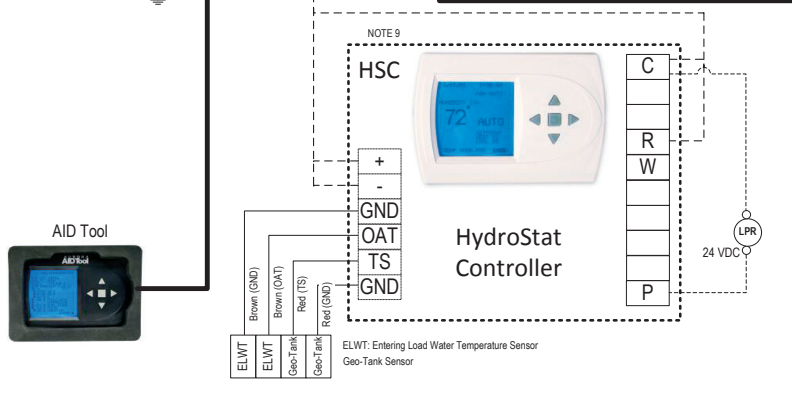

Legend

- Field Installed Item
- Factory Low voltage wiring
- Factory Line voltage wiring
- Field low voltage wiring
- Field line voltage wiring
- Optional block
- DC Voltage PCB traces
- Junction
- Quick connect terminal
- Wire nut
- Field wire lug
- Ground
- Relay Contacts- N.O., N.C.
- Fuse
- Breaker
- Thermistor
- Light emitting diode - Green
- Relay coil
- Capacitor w/ bleed resistor
- Switch - Condensate overflow
- Switch - High pressure
- Switch - Low pressure
- Polarized connector
- Current Transducer (CT)

CC - Compressor Contactor
 CO - Condensate overflow sensor
 K6 - DHW pump relay
 K5 - Loop pump relay
 HP - High pressure switch
 LP - Low pressure switch
 VIV - Vapor Injection Valve
 LPR - Load Pump Relay
 PB1, PB2 - Power blocks
 RV - Reversing Valve coil
 SW1 - DIP package 5 position AXB
 SW2 - TEST MODE ABC Board
 FP - Freeze Protection
 OAT - Outdoor Air Temperature

Wiring Schematics cont.

Variable Speed Pump (UPMXL 25-124)

Variable Speed Flow Center With 2 – UPMXL 25-124 Pumps

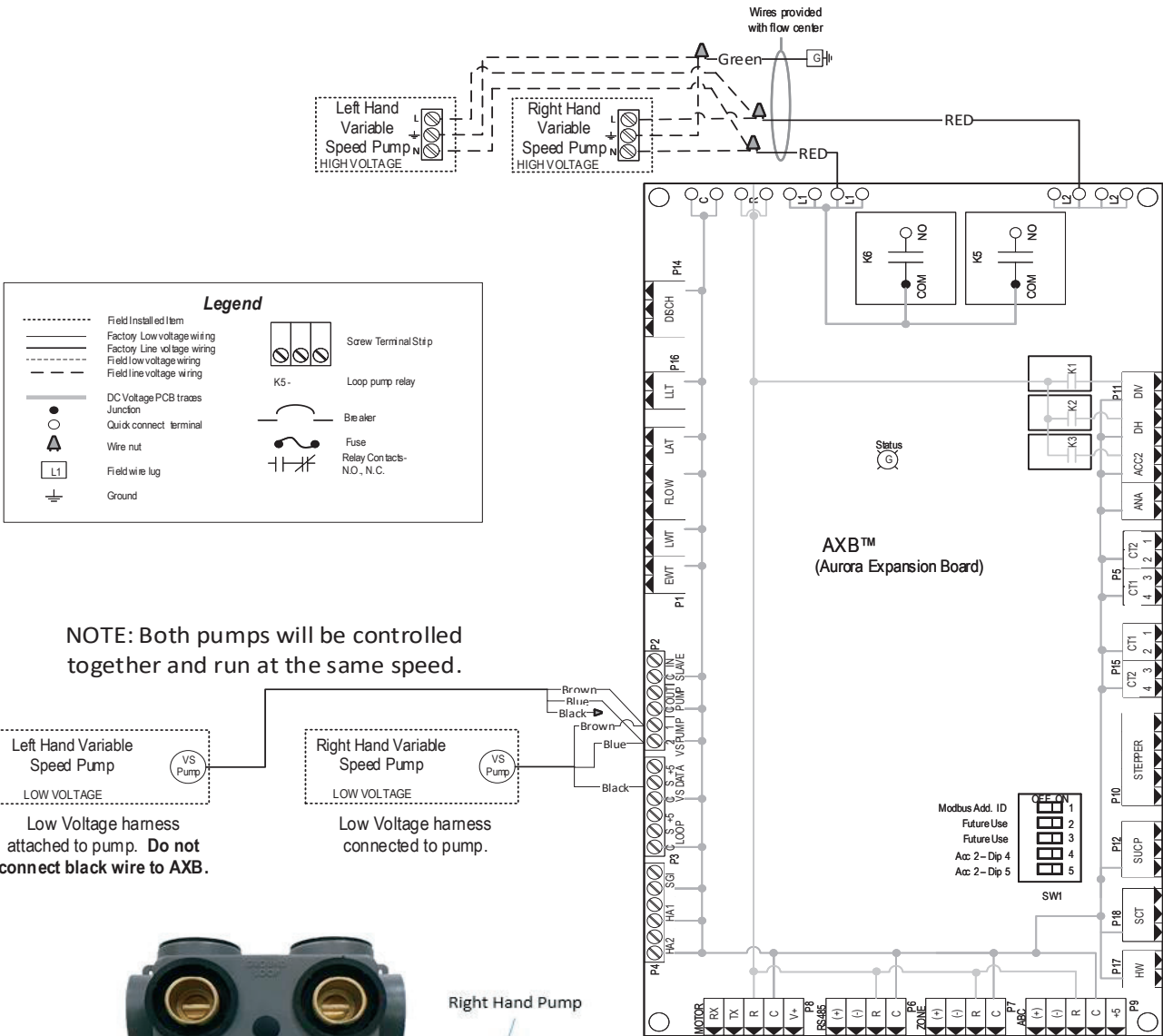

External Control

An external controller is necessary for operation. For water storage tank set point control the HydroStat HZC, and HZO may be used. A field supplied aquastat may also be used as the external control to the heat pump.

HydroStat features:

- Communicating Controller
- Pump Sampling
- 2 1/2" x 2 1/2" LCD display and five push buttons serve as the human interface
- Controls and regulates water tank temperature
- Fahrenheit or Celsius
- Symphony Compatibility
- Single Stage

HydroZone HZC features:

- 2 1/2" x 2 1/2" LCD display and five push buttons serve as the human interface
- Controls and regulates water tank temperature
- Fahrenheit or Celsius
- Outdoor reset
- Warm weather shutdown
- Single Stage

HydroZone HZO features:

- HZC mounted on 7.5" x 7.5" x 3.25" electrical box
- HydroZone relay board
- 2 1/2" x 2 1/2" LCD display and five push buttons serve as the human interface
- Controls and regulates water tank temperature
- Fahrenheit or Celsius
- Outdoor reset
- Warm weather shutdown
- Staging (up to 4 stages)
- Lead/Lag (when staging)

Converting to a Dedicated Cooling Unit

Procedure to Convert a Heating Only Unit to a Cooling Only Unit

All non-reversible units are built at the factory as dedicated heating units. Follow the procedures below to make the unit a dedicated cooling unit.

1. Shut off all power to the unit.
2. Remove the top and front access panel.
3. Refer to the labels on the unit for the location of ports and lines.
4. Connect the "Source Water-In" line to the port marked "Load Water-In." Then, connect the "Source Water-Out" line to the port marked "Load Water-Out."
5. Connect the "Load Water-In" line to the port marked "Source Water-In." Then, connect the "Load Water-Out" line to the port marked "Source Water-Out."
6. Flip flop locations for "FP1" and "FP2" thermistors. FP1 gets installed where FP2 is and FP2 installs where FP1 was.
7. Replace the top and front access panel.
8. Make sure all screws have been re-installed.
9. Turn on the power.

NOTE: A reversible unit **can not** be configured to heating only.

Unit Startup

Before Powering Unit, Check the Following:

NOTE: Remove and discard the compressor hold down shipping bolt located at the front of the compressor mounting bracket.

- **High voltage wiring is correct and matches the nameplate.**
- **Fuses, breakers and wire size are correct.**
- Piping is completed and water system has been cleaned and flushed.
- Air is purged from the closed loop system.
- Isolation valves are open and loop water control valves or loop pumps are wired.
- Service/access panels are in place.

Powering The Controls

Initial Configuration of the Unit

Before operating the unit, apply power and complete the following Aurora Startup procedure for the controls configuration. An AID Tool is recommended for setup, configuration and troubleshooting, especially with an Aurora 'Advanced' Control. AID Tool version 2.05 or greater is preferred.

1. Configure Aurora Screen

- a. In advanced controls - Confirm AXB is added and communicating.
- b. If HydroStat is installed, add 'TST' and ensure communication is present.

2. Aurora Setup Screen

- a. AXB Setup
 - i. DHW Enable - Ensure air is purged from HW system before enabling
 - ii. DHW Setpoint - 130 °F is the default but can be changed from 100 to 140 °F
- b. Sensor Kit Setup
 - i. Brine Selection - for HE/HR capacity calculation
 - ii. Flow Meter - activates the flow meter
 - iii. Activate energy option
Load pump and Aux heat current sensor activation
 - iv. Line Voltage calibration - Voltmeter required to calibrate line voltage during heating or cooling. Refer to Line Voltage Calibration in this manual for more details.
- e. Smart Grid Setup - Select Action option for utility received on-peak signal
- f. Home Automation 1 & 2 Setup - Select type of sensor for two home automation inputs.

Configuring the Sensor Kits

Configuring the Sensor kits

The Aurora Advanced Control allows Refrigeration, Energy, and Performance Monitoring sensor kits. These kits can be factory or field installed. The following description is for field activation of a factory installation of the sensor kits.

Energy Monitoring (Standard Sensor Kit on most 'Advanced' models)

The Energy Monitoring Kit includes two current transducers (load pump and electric heat) added to the existing two compressor sensors so that the complete power usage of the heat pump can be measured. The AID Tool provides a line voltage calibration procedure to improve accuracy. This information can be displayed on the AID Tool. Ensure the Energy Kit has been enabled by accessing the "Sensor Kit Setup" in the AID Tool and complete the following:

- a. Activate 'Energy Option' to activate the sensors for compressor (2), load pump and aux heat current.
- b. Select 'Pump' option of FC1, FC2, or open loop. Select 'Open Loop' if this heat pump is linked to a flow center through another heat pump. This selects the pump watts used in the calculation. Source pump watts are not measured but estimated.
- c. Line Voltage Calibration - Voltmeter required to calibrate line voltage during heating or cooling. Refer to Line Voltage Calibration in this manual for more details.
 - i. Turn on Unit in Heating or Cooling .
 - ii. Use multimeter at L1 and L2 to measure line voltage
 - iii. In the Sensor Kit Setup screen adjust the 'Base Voltage' to the nearest value to that is measured
 - iv. Then use the 'Fine Adjust' to select the exact voltage being measured at L1 and L2.
 - v. Exit 'Sensor Setup' Screen
- e. Power Adjustment: Refer to the Single Speed Power Adjustment tables in the Aurora 'Advanced' Control section of the literature
 - i. On the Main Menu screen select Setup
 - ii. Once in the Setup menu select the Power Adjustment Factor
 - iii. Power Adjustment - allows you to enter the unit's compressor power setting for high and low speed operation. Refer to the tables and use the voltage that is closest to the unit's line voltage and set the power adjustment accordingly.

Unit Startup cont.

- f. Energy monitoring can be read on any of the following components:
 - i. AID Tool - instantaneous information only
 - ii. WaterFurnace Web Portal via AWL device connected to Aurora

Refrigerant Monitoring (optional sensor kit)

The optional Refrigerant Monitoring Kit includes two pressure transducers, and three temperature sensors, heating liquid line (FP2), suction temperature and existing cooling liquid line (FP1). These sensors allow the measurement of discharge and suction pressures, suction and liquid line temperatures as well as superheat and subcooling. This information will only be displayed on the AID Tool. Ensure the Refrigerant Monitoring has been setup by accessing the 'Sensor Kit Setup' in the AID Tool and complete the following:

Once sensors are installed for discharge pressure, suction pressure, suction, liquid line cooling and liquid line heating no further setup is required.

- a. Turn on Unit in Heating or Cooling .
- b. Use the AID Tool to view the refrigerant performance in the 'Refrigerant Monitor' screen.
- c. Refrigerant monitoring can be read on any of the following components:
 - i. AID Tool - instantaneous information only
 - ii. WF Web Portal via AWL device connected to Aurora

Performance Monitoring (optional sensor kit)

The optional Performance Monitoring Kit includes three temperature sensors, source entering, source leaving, entering load water (HydroStat required to utilize) load leaving water temperature and a field installed water flow rate sensor. With this kit heat of extraction and rejection will be calculated. This requires configuration using the AID Tool for selection of water or antifreeze. Ensure the Energy Kit has been enabled by accessing the 'Sensor Kit Setup' in the AID Tool and complete the following:

- a. Select 'Brine' - and then choose Water or Antifreeze for the proper factor
- b. Select 'Flowmeter' to activate the flow sensor choose the appropriate 3/4 in. (018-025 models), 1 in. (040-075 models), or none.
- c. Turn on Unit in Heating or Cooling .
- d. Use the AID Tool to view the performance in the 'Performance Monitor' screen.
- e. Performance monitoring can be read on any of the following components:
 - i. AID tool - instantaneous information only
 - ii. WaterFurnace Web Portal via AWL device connected to Aurora.

The Aurora Base Control System

Aurora ‘Base’ Control

The Aurora ‘Base’ Control (ABC) System is a complete residential and commercial comfort system that brings all aspects of the HVAC system into one cohesive module network. The ABC features microprocessor control and HP, LP, condensate and freeze detection, over/under voltage faults, along with communicating thermostat capability for complete fault detection text at the thermostat.

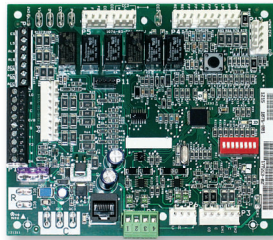

Aurora uses the Modbus communication protocol to communicate between modules. Each module contains the logic to control all features that are connected to the module. The Aurora ‘Base’ Control (ABC) has two Modbus channels. The first channel is configured as a master for connecting to devices such as a communicating thermostat, expansion board, or other slave devices. The second channel is configured as a slave for connecting the Aurora Interface Diagnostics Tool (AID Tool).

Aurora ‘Advanced’ Control

The Aurora ‘Advanced’ Control expands on the capability of the Aurora ‘Base’ Control (ABC) System by adding the Aurora Expansion Board (AXB). The additional features include compressor current monitoring, loop pump linking, intelligent hot water generator control, variable speed pump capability, and also allows for optional energy, refrigeration, and performance monitoring factory installed add-on sensor kits. The AXB also features a second field configurable accessory relay, and two home automation inputs that are AID configurable for different types of alarms from sump pumps to home security. The Smart Grid input is AID configurable with many options to react to Utility controlled relay operation for ON Peak optimization.

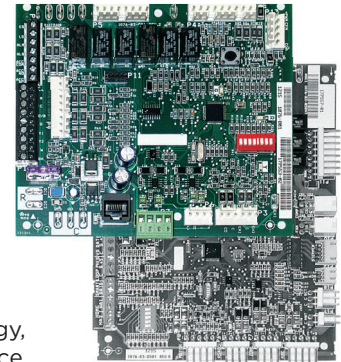

Aurora Control Features	Description	Aurora ‘Base’	Aurora ‘Advanced’
Microprocessor Compressor Control	Microprocessor control of compressor for timings with FP1, HP, LP, Condensate, assignable Acc relay	•	•
Advanced Microprocessor Features	Smart Grid, Home Automation Alarm Inputs, and Accessory2 Relay (HRV/ERV)	-	•
Base Hot Water Generator Operation	Compressor Contactor powers Hot Water Generator Pump with inline circuit breaker and thermostat limit.	•	See below
Advanced Hot Water Generator Control	Microprocessor and separate power relay for Hot Water Generator Pump with digital temperature monitoring and multiple HWG setpoint selection.	-	•
Base Loop Pump Control	Compressor Contactor powers Loop Pump with inline circuit breaker and no loop pump linking capability.	•	See below
Advanced Speed Pump Control	Microprocessor and separate power relay for loop pump and inline circuit breakers and loop pump linking.	-	•
Compressor Monitoring	Control monitors compressor starts for high current, missing leg etc.	-	•
Smart Grid/Utility Input	Allows simple input to externally enable of occupied/unoccupied mode for basic utility time of use programs.	-	Dry Contact x1
Home Automation Alarm Input	Allows simple input to signal sump, security, or smoke/CO sensor alarms from other home automation or security systems. The two inputs can be field configured to a number of options and logic.	-	Dry Contactx2
HAN/Smart Grid Com (AWL and Portal) Kit	Allows direct communication of the Aurora to Smart Meters, Home Automation Network and Internet.	-	Optional AWL

The Aurora Base Control System cont.

Service Device	Description	Aurora 'Base'	Aurora 'Advanced'
 <p>Aurora Interface and Diagnostics (AID) Tool</p>	<p>Allows setup, monitoring and troubleshooting of any Aurora Control.</p> <p>NOTE: Although the ABC has basic compatibility with all Aurora, new product features may not be available on older AID Tools. To simplify the basic compatibility ensure the version of AID is at least the same or greater than the ABC software version.</p>	For Service (Ver. 1.xx or greater)	For Service (Ver. 2.xx or greater)

Add On Control Feature Kits (field or factory installed)	Description	Aurora 'Base'	Aurora 'Advanced'
Geo Energy Monitoring Kit	Monitors realtime power consumption of compressor, aux heat and pump. AXB required.	-	Standard
Refrigeration Monitoring Kit	Monitors realtime pressures, temperatures, superheat, and subcooling. AXB required.	-	Optional Sensor Kit
Performance Monitoring Kit	Monitors water temperatures and water flow rate and calculates heat of extraction/rejection. AXB required.	-	Optional Sensor Kit
Data Logging (AWL) Kit	Allows data logging of up to 12 months. AXB required. Can also be temporarily installed for troubleshooting.	-	Optional
HAN/Smart Grid Com (AWL and Portal) Kit	Allows direct communication of the Aurora to Smart Meters, HAN, and internet. AXB required.	-	Optional
AXB Kit for advanced hot water generator control, flow center linking, variable speed pump	Added to ABC only units for key features of advanced hot water generator control and advanced loop control/linking.	Optional (Field Kit)	Standard

Add On Thermostats and Zoning	Description	Aurora 'Base'	Aurora 'Advanced'
HydroStat	Communicating controller for one hydronic heat pump.	Optional	Optional
HZO	Non-communicating controller for up to four heat pumps.	Optional	Optional
HZC	Non-communicating controller for one hydronic heat pump	Optional	Optional

The Aurora Base Control System cont.

Aurora 'Base' Control

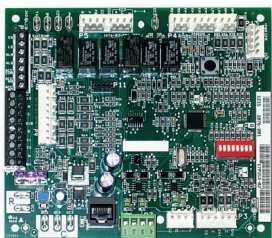

NOTE: Refer to the Aurora Base Control Application and Troubleshooting Guide and the Instruction Guide: Aurora Interface and Diagnostics (AID) Tool for additional information.

Control Features

- Random start at power up
- Anti-short cycle protection
- High and low pressure cutouts
- Loss of charge
- Water coil freeze detection
- Over/under voltage protection
- Load shed
- Emergency shutdown
- Diagnostic LED
- Test mode push button switch
- Alarm output
- Accessory output with N.O. and N.C.
- Modbus communication (master)
- Modbus communication (slave)

Field Selectable Options via Hardware

DIP Switch (SW1) – Test/Configuration Button (See SW1 Operation Table)

Test Mode

The control is placed in the test mode by holding the push button switch SW1 for 2 - 5 seconds. In test mode most of the control timings will be shortened by a factor of sixteen (16). LED3 (green) will flash at 1 second on and 1 second off. Additionally, when entering test mode LED1 (red) will flash the last lockout one time. Test mode will automatically time out after 30 minutes. Test mode can be exited by pressing and holding the SW1 button for 2 to 5 seconds or by cycling the power. **NOTE:** Test mode will automatically be exited after 30 minutes.

Reset Configuration Mode

The control is placed in reset configuration mode by holding the push button switch SW1 for 50 to 60 seconds. This will reset all configuration settings and the EEPROM back to the factory default settings. LED3 (green) will turn off when entering reset configuration mode. Once LED3 (green) turns off, release SW1 and the control will reset.

DIP Switch (SW2)

SW2-1 (Source) FP1 Selection – Low water coil temperature limit setting for freeze detection. On = 30°F; Off = 15°F.

SW2-2 (Load) FP2 Selection – On = 30°F; Off = 15°F

SW2-3 RV – O/B - thermostat type. Heat pump thermostats with “O” output in cooling or “B” output in Heating can be selected. On = O; Off = B.

SW2-4 Access Relay Operation (P2)
and 2-5

Access Relay Operation	SW2-4	SW2-5
Cycle with Blower		n/a
Cycle with Compressor	OFF	OFF
Water Valve Slow Opening	ON	OFF
Cycle with Comm. T-stat Hum Cmd		n/a

Cycle with Blower - (Not used on water-to-water)

Cycle with Compressor - The accessory relay will cycle with the compressor output.

Water Valve Slow Opening - The accessory relay will cycle and delay both the blower and compressor output for 90 seconds.

SW2-6 CC Operation – selection of single or dual capacity compressor. On = Single Stage; Off = Dual Capacity

SW2-7 Lockout and Alarm Outputs (P2) – selection of a continuous or pulsed output for both the LO and ALM Outputs. On = Continuous; Off = Pulsed

SW2-8 *Future Use*

Alarm Jumper Clip Selection

From the factory, ALM is connected to 24 VAC via JW2. By cutting JW2, ALM becomes a dry contact connected to ALG.

Field Selectable Options via Software

(Selectable via the Aurora AID Tool)

Safety Features

The following safety features are provided to protect the compressor, heat exchangers, wiring and other components from damage caused by operation outside of design conditions.

Fuse – a 3 amp automotive type plug-in fuse provides protection against short circuit or overload conditions.

Anti-Short Cycle Protection – 4 minute anti-short cycle protection for the compressor.

Random Start – 5 to 80 second random start upon power up.

The Aurora Base Control System cont.

Fault Retry - in the fault condition, the control will stage off the outputs and then “try again” to satisfy the thermostat Y input call. Once the thermostat input calls are satisfied, the control will continue on as if no fault occurred. If 3 consecutive faults occur without satisfying the thermostat Y input call, then the control will go to Lockout mode.

Lockout - The Alarm output (ALM) and Lockout output (L) will be turned on. The fault type identification display LED1 (Red) shall flash the fault code. To reset lockout conditions with SW2-8 On, thermostat inputs “Y1”, “Y2”, and “W” must be removed for at least 3 seconds. To reset lockout conditions with SW2-8 Off, thermostat inputs “Y1”, “Y2”, “W”, and “DH” must be removed for at least 3 seconds. Lockout may also be reset by turning power off for at least 30 seconds or by enabling the emergency shutdown input for at least 3 seconds.

High Pressure - fault is recognized when the Normally Closed High Pressure Switch, P4-9/10 opens, no matter how momentarily. The High Pressure Switch is electrically in series with the Compressor Contactor and serves as a hard-wired limit switch if an overpressure condition should occur.

Low Pressure - fault is recognized when the Normally Closed Low Pressure Switch, P4-7/8 is continuously open for 30 seconds. Closure of the LPS any time during the 30 second recognition time restarts the 30 second continuous open requirement. A continuously open LPS shall not be recognized during the 2 minute startup bypass time.

Loss of Charge - fault is recognized when the Normally Closed Low Pressure Switch, P4-7/8 is open prior to the compressor starting.

Freeze Detection (Source Coax) - set points shall be either 30°F or 15°F. When the thermistor temperature drops below the selected set point, the control shall begin counting down the 30 seconds delay. If the thermistor value rises above the selected set point, then the count should reset. The resistance value must remain below the selected set point for the entire length of the appropriate delay to be recognized as a fault. This fault will be ignored for the initial 2 minutes of the compressor run time.

Freeze Detection (Load Coax) - uses the FP2 input to protect against ice formation on the coax. The FP2 input will operate exactly like FP1.

Over/Under Voltage Shutdown - An over/under voltage condition exists when the control voltage is outside the range of 18 VAC to 30 VAC. If the over/under voltage shutdown lasts for 15 minutes, the lockout and alarm relay will be energized. Over/under voltage shutdown is self-resetting in that if the voltage comes back within range of 18 VAC to 30 VAC for at least 0.5 seconds, then normal operation is restored.

Operation Description

Power Up - The unit will not operate until all the inputs and safety controls are checked for normal conditions. The unit has a 5 to 80 second random start delay at power up. Then the compressor has a 4 minute anti-short cycle delay after the random start delay.

Standby In standby mode, Y1, Y2, W, DH, and G are not active. Input O may be active. The blower and compressor will be off.

Heating Operation

Heating, 1st Stage (Y1) - The compressor is energized 10 seconds after the Y1 input is received.

Cooling Operation

In all cooling operations, the reversing valve directly tracks the O input. Thus, anytime the O input is present, the reversing valve will be energized.

Cooling, 1st Stage (Y1, O) - The compressor is energized 10 seconds after the Y1 input is received.

Emergency Shutdown - Four (4) seconds after a valid ES input, P2-7 is present, all control outputs will be turned off and remain off until the emergency shutdown input is no longer present. The first time that the compressor is started after the control exits the emergency shutdown mode, there will be an anti-short cycle delay followed by a random start delay. Input must be tied to common to activate.

Load Shed - The LS input disables all outputs with the exception of the blower output. When the LS input has been cleared, the anti-short cycle timer and random start timer will be initiated. Input must be tied to common to activate.

The Aurora Base Control System cont.

Aurora 'Base' Control LED Displays

These three LEDs display the status, configuration, and fault codes for the control. These can also be read in plain English via the Aurora AID Tool.

Status LED (LED3, Green)

Description of Operation	Fault LED, Green
Normal Mode	ON
Control is Non-functional	OFF
Test Mode	Slow Flash
Lockout Active	Fast Flash
Dehumidification Mode	Flash Code 2
(Future Use)	Flash Code 3
(Future Use)	Flash Code 4
Load Shed	Flash Code 5
ESD	Flash Code 6
(Future Use)	Flash Code 7

Fault LED (LED1, Red)

Red Fault LED		LED Flash Code*	Lockout	Reset/Remove
ABC Basic Faults	Normal - No Faults	OFF	-	
	Fault - Input	1	No	Auto
	Fault - High Pressure	2	Yes	Hard or Soft
	Fault - Low Pressure	3	Yes	Hard or Soft
	Fault - Freeze Detection FP2	4	Yes	Hard or Soft
	Fault - Freeze Detection FP1	5	Yes	Hard or Soft
	Fault - Condensate Overflow	7	Yes	Hard or Soft
	Fault - Over/Under Voltage	8	No	Auto
	Fault - FP1 & FP2 Sensor Error	11	Yes	Hard or Soft

NOTE: All codes >11 use long flash for tens digit and short flash for the ones digit. 20, 30, 40, 50, etc. are skipped.

ABC Control Board Layout

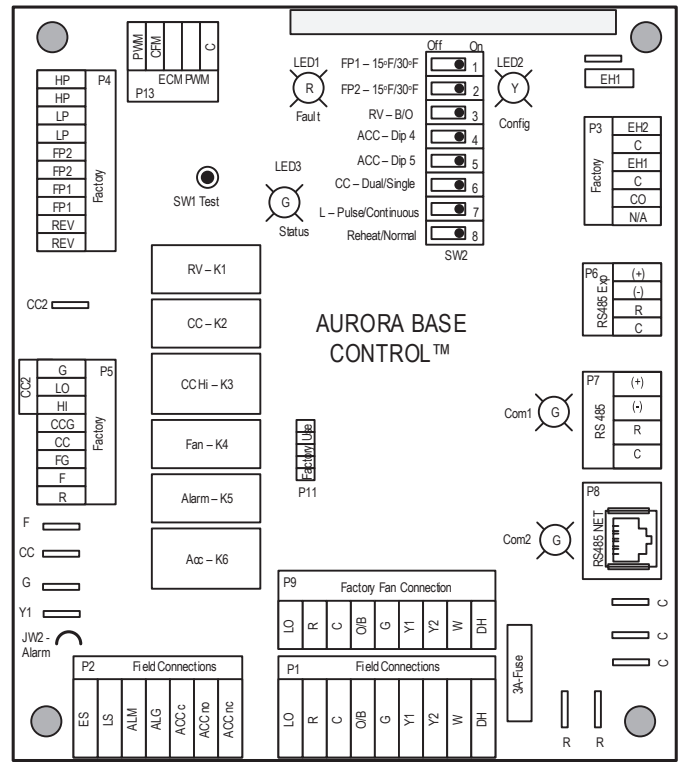

Aurora Interface and Diagnostics (AID) Tool

The Aurora Interface and Diagnostics (AID) Tool is a device that is a member of the Aurora network. The AID Tool is used to troubleshoot equipment which uses the Aurora control via Modbus RTU communication. The AID Tool provides diagnostics, fault management, ECM setup, and system configuration capabilities to the Aurora family of controls. An AID Tool is recommended, although not required, for ECM airflow settings. The AID Tool simply plugs into the exterior of the cabinet in the AID Tool port.



The Aurora ‘Advanced’ Control System

Aurora ‘Advanced’ Control Features

The Aurora ‘Advanced’ Control system expands on the capability of the Aurora ‘Base’ Control (ABC) by adding the Aurora Expansion Board (AXB). All of the preceding features of the Aurora ‘Base’ Control are included. The following control description is of the additional features and capability of the Aurora advanced control.

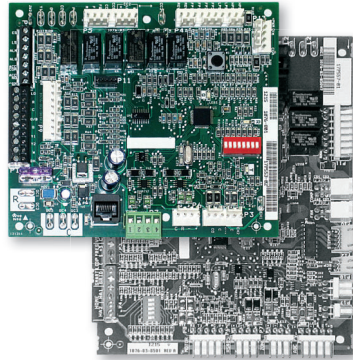

It is highly recommended the installing/servicing contractor obtain an Aurora Interface and Diagnostic Tool (AID) and specialized training before attempting to install or service an Aurora ‘Advanced’ control system.



The additional AXB features include the following:

AXB DIP Switch

DIP 1 - ID: This is the AXB ModBus ID and should always read On.

DIP 2 & 3 - Future Use

DIP 4 & 5 - Accessory Relay2: A second, DIP configurable, accessory relay is provided that can be cycled with the compressor 1 or 2, blower, or the Dehumidifier (DH) input. This is to complement the Accessory 1 Relay on the ABC board.

Position	DIP 4	DIP 5	Description
1	ON	ON	Cycles with Fan or ECM (or G)
2	OFF	ON	Cycles with CC1 first stage of compressor or compressor spd 6
3	ON	OFF	Cycles with CC2 second stage of compressor or compressor spd 7-12
4	OFF	OFF	Cycles with DH input from ABC board

Advanced Hot Water Generator Control (Domestic Hot Water Option)

In lieu of the ‘Base Hot Water Generator Control’, the Advanced features an AID Tool selectable temperature limit and microprocessor control of the process. This will maximize hot water generation and prevent undesirable energy use. An alert will occur when the hot water input temperature is at or above setpoint (100°F - 140°F) for 30 continuous seconds (130°F is the default setting). This alert will appear as an E15 on the AID Tool and the hot water pump de-energizes. Hot water pump operations resume on the next compressor cycle or after 15 minutes of continuous compressor operation during the current thermostat demand cycle. Since compressor hot gas temperature is dependent on loop temperature in cooling mode, loop temperatures may be too low to allow proper heating of water. The control will monitor water and refrigerant temperatures to determine if conditions are satisfactory for heating water. LED1 (red LED) will flash code 15 when the DHW limit is reached and when conditions are not favorable for water heating. Error code 15 will also be displayed on the AID Tool in the fault screen. This flash code is a noncritical alert and does not necessarily indicate a problem.

Compressor Monitoring

The AXB includes two current transducers to monitor the compressor current and starting characteristics. Open circuits or welded contactor faults will be detected. A fault will produce an E10 code.

Loop Pump Linking

This input and output are provided so that two units can be linked together with a common flow center. When either unit has a call for loop pump, both unit’s loop pump relays and variable speed pumps are energized. The flow center then can simply be wired to either unit. The output from one unit should be routed to the input of the other. If daisy chained up to 16 heat pumps can be wired and linked together in this fashion.

Advanced Communication Ports

Communication ports P6 and P8 will provide future expansion via dedicated protocols. These are for future use.

The Aurora 'Advanced' Control System cont.

Smart Grid-On Peak (SG) Input

The 'On Peak' input was designed to allow utilities to utilize simple radio controlled switches to control the On Electric Peak behavior of the 5 and 7 Series Geothermal Heat Pumps. With a closed contact signal, this input will limit the operation and thus the power consumption of the unit by one of the below selections. The AID Tool will allow configuration of this input for the action of:

- No Action
- Disable compressor operation until removed
- Go to On Peak thermostat settings until removed [Requires Com T-Stat] (Future Release)
- Compressor limited to 50% or low cap until removed [dual capacity or variable speed only] (Future Release)
- Disable compressor operation for 1/2 hr (can be removed immediately) (Future Release)

Then Flash Code 7 on the Green LED for the 'On Peak' mode. And On Peak will display on communicating thermostats.

Home Automation 1 and 2 Inputs

The Home automation inputs are simple closed contact inputs that will trigger an AID Tool and thermostat alert for the homeowner. These would require optional sensors and or equipment for connection to the AXB board. With two inputs two different sensors can be selected. The selected text will then be displayed on the AID Tool and communicating thermostats. These events will NOT alter functionality or operation of the heat pump/accessories and is for homeowner/service notification only.

Home Automation 1 - E23 HA1

With a closed dry contact signal, this input will cause an alarm and Alert Code 23 to indicate on the stat or flash on ABC. The AID Tool will allow configuration of this input between the following selections:

- No Action
- Home Automation Fault [no lockout info only]
 - Output from home automation system
- Security Alarm [no lockout info only]
 - Output from home security
- Sump Alarm Fault [no lockout info only]
 - Switch output from sump sensor
- Smoke/CO Alarm Fault [no lockout info only]
 - Switch output from Smoke/CO sensor
- Dirty Filter Alarm [no lockout info only]
 - Output from dirty filter sensor

Home Automation 2 - E24 HA2

With a closed dry contact signal, this input will cause an alarm and Alert Code 24 to indicate on the stat or flash on ABC. The AID Tool will allow configuration of this input between the following selections:

- No Action
- Home Automation Fault [no lockout info only]
 - Output from home automation system
- Security Alarm [no lockout info only]
 - Output from home security
- Sump Alarm Fault [no lockout info only]
 - Switch output from sump sensor
- Smoke/CO Alarm Fault [no lockout info only]
 - Switch output from Smoke/CO sensor
- Dirty Filter Alarm [no lockout info only]
 - Output from dirty filter sensor

Monitoring Sensor Kits

Energy Monitoring

(Standard Sensor Kit on 'Advanced' models)

The Energy Monitoring Kit includes two current transducers (load pump and electric heat) added to the existing two compressor sensors so that the complete power usage of the heat pump can be measured. The AID Tool provides a line voltage calibration procedure to improve the accuracy, and a power adjustment setting that allows the compressor power to be adjusted to match the units line voltage using the provided tables. This information can be displayed on the AID Tool.

Refrigerant Monitoring (optional sensor kit)

The optional Refrigerant Monitoring Kit includes two pressure transducers, and three temperature sensors, heating liquid line, suction temperature and existing cooling liquid line (FPI). These sensors allow the measurement of discharge and suction pressures, suction and liquid line temperatures as well as superheat and subcooling. This information will only be displayed on the AID Tool.

Performance Monitoring (optional sensor kit)

The optional Performance Monitoring Kit includes three temperature sensors, source entering, source leaving, and leaving load water, and a water flow rate sensor. With this kit heat of extraction and rejection will be calculated. This requires configuration using the AID Tool for selection of water or antifreeze.

Power Adjustment Table

Model	Voltage		
	208	230	250
018	0.99	0.97	0.96
025	0.99	0.99	0.95
040	0.99	0.98	0.92
050	0.99	0.97	0.90
060	0.98	0.96	0.87
075	0.98	0.97	0.85

The Aurora 'Advanced' Control System cont.

Aurora 'Advanced' Control LED Displays

These three LEDs display the status, configuration, and fault codes for the control. These can also be read in plain English via the Aurora AID Tool.

Status LED (LED3, Green)

Description of Operation	Fault LED, Green
Normal Mode	ON
Control is Non-functional	OFF
Test Mode	Slow Flash
Lockout Active	Fast Flash
Dehumidification Mode	Flash Code 2
Load Shed	Flash Code 5
Emergency Shutdown	Flash Code 6
On Peak Mode	Flash Code 7
(Future Use)	Flash Code 8
(Future Use)	Flash Code 9

Configuration LED (LED2, Yellow)

Description of Operation	Configuration LED, Yellow
No Software Overwritten	ECM Setting
DIP Switch Overwritten	Slow Flash
ECM Configuration Mode	Fast Flash
Reset Configuration Mode	OFF

Fault LED (LED1, Red)

	Red Fault LED	LED Flash Code *	Lockout	Reset/Remove	Fault Condition Summary
ABC Basic Faults	Normal - No Faults	Off	-		
	Fault-Input	1	No	Auto	Tstat input error. Autoreset upon condition removal.
	Fault-High Pressure	2	Yes	Hard or Soft	HP switch has tripped (>600 psi)
	Fault-Low Pressure	3	Yes	Hard or Soft	Low Pressure Switch has tripped (<40 psi for 30 continuous sec.)
	Fault-Freeze Detection FP2	4	Yes	Hard or Soft	Freeze protection sensor has tripped (<15 or 30 degF for 30 continuous sec.)
	Fault-Freeze Detection FP1	5	Yes	Hard or Soft	Freeze protection sensor has tripped (<15 or 30 degF for 30 continuous sec.)
	Fault-Condensate Overflow	7	Yes	Hard or Soft	Condensate switch has shown continuity for 30 continuous sec.
	Fault-Over/Under Voltage	8	No	Auto	Instantaneous voltage is out of range. **Controls shut down until resolved.
ABC & AXB Advanced Faults	Fault-FP1 Snsr Error	11	Yes	Hard or Soft	If FP1 Sensor Error
	Fault-Compressor Monitor	10	Yes	Hard or Soft	Open Crkt, Run, Start or welded cont
	Non-CriticAXBSnsrErr	13	No	Auto	Any Other Sensor Error
	CriticAXBSnsrErr	14	Yes	Hard or Soft	Sensor Error for EEV or HW
	Alert-HotWtr	15	No	Auto	HW over limit or logic lockout. HW pump deactivated.
	Fault-VarSpdPump	16	No	Auto	Alert is read from PWM feedback.
	Not Used	17	No	Auto	IZ2 Com Fault. Autoreset upon condition removal.
	Non-CritComErr	18	No	Auto	Any non-critical com error
	Fault-CritComErr	19	No	Auto	Any critical com error. Auto reset upon condition removal
	Alarm - Low Loop Pressure	21	No	Auto	Loop pressure is below 3 psi for more than 3 minutes
	Alarm - Home Automation 1	23	No	Auto	Closed contact input is present on Dig 2 input - Text is configurable
	Alarm - Home Automation 2	24	No	Auto	Closed contact input is present on Dig 3 input - Text is configurable

NOTES:

*All codes >11 use long flash for tens digit and short flash for the ones digit. 20, 30, 40, 50 etc. are skipped!

Alert' is a noncritical sensor or function that has failed. Normal operation of the heat pump is maintained but service is desired at some point.

Reference Calculations

<p>Heating Calculations:</p> $LWT = EWT - \frac{HE}{GPM \times C^*}$ $HE = C^* \times GPM \times (EWT - LWT)$	<p>Cooling Calculations:</p> $LWT = EWT + \frac{HR}{GPM \times C^*}$ $HR = C^* \times GPM \times (LWT - EWT)$
--	--

NOTE: * C = 500 for pure water, 485 for brine.

Legend and Notes

Abbreviations and Definitions

ELT = entering load fluid temperature to heat pump	kW = kilowatts
SWPD = source coax water pressure drop	EST = entering source fluid temperature to heat pump
LLT = leaving load fluid temperature from heat pump	HE = heat extracted in MBTUH
PSI = pressure drop in pounds per square inch	LST = leaving source fluid temperature from heat pump
LGPM = load flow in gallons per minute	HC = total heating capacity in MBTUH
FT HD = pressure drop in feet of head	COP = coefficient of performance, heating [HC/kW x 3.413]
LWPD = load coax water pressure drop	EER = energy efficiency ratio, cooling
LWT = leaving water temperature	TC = total cooling capacity in MBTUH
EWT = entering water temperature	HR = heat rejected in MBTUH
Brine = water with a freeze inhibiting solution	

Notes to Performance Data Tables

The following notes apply to all performance data tables:

- Three flow rates are shown for each unit. The lowest flow rate shown is used for geothermal open loop/well water systems with a minimum of 50°F EST. The middle flow rate shown is the minimum geothermal closed loop flow rate. The highest flow rate shown is optimum for geothermal closed loop systems and the suggested flow rate for boiler/tower applications.
- Entering water temperatures below 40°F assumes 15% antifreeze solution.
- Interpolation between ELT, EST, and GPM data is permissible.
- Operation in the gray areas is not recommended.

Pressure Drop

Model	GPM	Pressure Drop (psi)				
		30°F	60°F	80°F	100°F	120°F
018R*	3.0	0.5	0.4	0.4	0.3	0.3
	4.0	1.1	0.9	0.9	0.8	0.8
	5.0	1.6	1.4	1.4	1.3	1.3
	6.0	2.1	1.9	1.9	1.8	1.8
025R*	4.0	0.7	0.6	0.4	0.3	0.3
	5.5	1.3	1.1	0.9	0.7	0.6
	7.0	1.9	1.7	1.5	1.3	1.2
	8.5	2.6	2.4	2.2	2.0	1.9
040H/R	5.0	0.9	0.6	0.6	0.5	0.5
	7.5	2.3	2.1	2.0	1.9	1.8
	10.0	3.7	3.5	3.3	3.2	3.0
	12.5	5.0	4.7	4.4	4.2	4.0
050H/R	8.0	1.7	1.4	1.4	1.3	1.3
	11.5	3.6	3.4	3.2	3.0	2.8
	15.0	5.6	5.4	5.0	4.6	4.2
	18.5	8.3	8.1	7.6	7.2	6.8
060H/R	9.0	1.4	1.1	1.0	1.0	0.9
	13.5	4.2	3.9	3.5	3.1	2.7
	18.0	6.9	6.7	6.0	5.2	4.5
	22.5	10.7	10.5	10.0	9.4	8.7
075H/R	10.0	3.2	3.0	2.8	2.7	2.5
	14.5	5.5	5.3	5.1	4.9	4.7
	19.0	7.9	7.6	7.3	7.1	6.8
	23.5	11.5	11.3	11.0	10.8	10.5

NOTES: Temperatures are Entering Water Temperatures 8/9/10
 *Domestic water heating units source side pressure drop and reversible units load and source pressure drop.

Vented Only Load Side

Model	GPM	Pressure Drop (psi)			
		60°F	80°F	100°F	120°F
018H	3.0	0.5	0.4	0.4	0.3
	4.0	1.4	1.3	1.2	1.2
	5.0	2.2	2.1	2.1	2.0
	6.0	3.0	2.9	2.9	2.8
025H	4.0	1.3	1.3	1.2	1.2
	5.5	3.0	2.9	2.8	2.7
	7.0	4.6	4.4	4.3	4.1
	8.5	6.7	6.5	6.4	6.2

NOTES: Temperatures are Entering Water Temperatures. 7/13/09
 Double wall vented coax for heating potable water

Operating Limits

Operating Limits	Cooling		Heating	
	°F	°C	°F	°C
Source Side Water Limits				
Minimum Entering Water	30	-1.1	20	-6.7
Normal Entering Water	85	29.4	60	15.6
Maximum Entering Water	110	43.3	90	32.2
Load Side Water Limits				
Minimum Entering Water	50	10.0	60	15.6
Normal Entering Water	60	15.6	100	37.8
Maximum Entering Water	90	32.2	120	48.9

NOTES: Minimum/maximum limits are only for start-up conditions, and are meant for bringing the space up to occupancy temperature. Units are not designed to operate at the minimum/maximum conditions on a regular basis. The operating limits are dependant upon three primary factors: 1) entering source temperature, 2) entering load temperature, and 3) flow rate (gpm). When any of the factors are at the minimum or maximum levels, the other two factors must be at the normal level for proper and reliable unit operation. Consult the Capacity Tables for each model to determine allowable normal operating conditions. Units are not designed for outdoor installation.

Physical Data

Model	018	018 Heating	025	025 Heating	040	050	060	075
Compressor (1 each)	Scroll							
Factory Charge R410a, oz [kg]	44.0 [1.25]	36 [1.02]	58.0 [1.64]	46.0 [1.30]	66 [1.87]	68 [1.93]	104 [2.95]	110 [3.12]
Coax & Piping Water Volume - gal [l]	.52 [1.97]	.52 [1.97]	.89 [3.38]	.89 [3.38]	1.0 [3.94]	1.4 [5.25]	1.6 [6.13]	1.6 [6.13]
Weight - Operating, lb [kg]	191 [86.6]	191 [86.6]	225 [102.1]	225 [102.1]	290 [131.5]	325 [147.4]	345 [156.5]	345 [156.5]
Weight - Packaged, lb [kg]	213 [96.6]	213 [96.6]	247 [112.0]	247 [112.0]	305 [138.3]	340 [154.2]	360 [163.3]	360 [163.3]

8/2/09

Flow Rates

Source Flow Rates

Model	Minimum Open Loop Flow Rate	Minimum Closed Loop Flow Rate	Normal Load Flow Rate	Maximum Flow Rate
018	3.0	4.0	5.0	7.0
025	4.0	5.0	7.0	9.0
040	5.0	8.0	10.0	12.0
050	8.0	12.0	15.0	17.0
060	9.0	13.0	18.0	20.0
075	10.0	14.0	19.0	21.0

5/15/09

Load Flow Rates

Model	Minimum Load Flow Rate	Normal Load Flow Rate	Maximum Flow Rate
018	3.0	5.0	7.0
025	4.0	7.0	9.0
040	5.0	10.0	12.0
050	8.0	15.0	17.0
060	9.0	18.0	20.0
075	10.0	19.0	21.0

5/15/09

Thermistor and Compressor Resistance

Thermistor Table

Thermistor Temperature (°F)	Resistance (Ohms)
78.8	9,230 - 10,007
77.5	9,460 - 10,032
76.5	9,690 - 10,580
75.5	9,930 - 10,840
33.5	30,490 - 32,080
32.5	31,370 - 33,010
31.5	32,270 - 33,690
30.5	33,190 - 34,940
1.5	79,110 - 83,750
0.5	81,860 - 86,460
0.0	82,960 - 87,860

Compressor Resistance Table (77°F)

Terminals	018 ZP16K5E	025 ZP25K5E	040 HRH034U	050 ZP51K5E	060 HRH056U	075 HLJ072T
C to S	2.14 - 2.28	1.77-2.03	1.30 - 1.49	0.74 - 0.85	0.76 - 0.88	0.78 - 0.90
C to R	1.42 - 1.64	0.95-1.09	0.49 - 0.57	0.42 - 0.48	0.26 - 0.30	0.27 - 0.31
S to R	3.56 - 4.10	2.72-3.12	1.79 - 2.06	1.16 - 1.33	1.02 - 1.18	1.05 - 1.21

NOTE: Resistance listed are for single phase (208-230/60Hz) compressors. 1/15/15

Operating Parameters

Heating Mode

Entering Load Temp (°F)	Entering Source Temp (°F)	Suction Pressure (psig)	Discharge Pressure (psig)	Superheat (°F)	Subcooling (°F)
60	20	52-67	195-227	8-16	5-15
	30	67-82	208-235	7-14	6-14
	50	95-113	216-245	7-14	6-12
	70	124-144	225-255	8-19	5-15
	90	143-167	230-275	14-26	8-12
80	20	54-69	283-316	8-16	7-15
	30	69-84	293-323	10-12	7-18
	50	98-125	302-335	12-14	8-16
	70	121-148	311-346	14-18	8-16
	90	144-179	319-363	14-26	8-16
100	20	56-71	369-405	8-10	6-14
	30	77-85	378-411	10-12	7-15
	50	104-126	388-425	12-14	7-15
	70	123-152	398-438	14-18	3-12
	90	148-191	408-452	14-22	3-12
120	20	59-74	455-495	8-18	4-16
	30	74-87	464-500	6-16	5-17
	50	106-128	474-515	5-17	5-15
	70	125-156	485-530	6-16	4-15
	90	Operation not recommended			

NOTES: Operating parameters at 3 gpm/ton source and load flow. Consult the Capacity Tables for each model for normal allowable operating conditions. Some of the conditions shown above are outside of the compressor operational limits for specific models.

Cooling Mode

Entering Load Temp (°F)	Entering Source Temp (°F)	Suction Pressure (psig)	Discharge Pressure (psig)	Superheat (°F)	Subcooling (°F)
50	30	86-99	135-160	12-22	2-15
	50	92-107	191-214	10-19	4-15
	70	98-115	248-268	5-15	6-16
	90	101-119	335-367	6-15	8-16
	110	105-122	425-465	8-16	10-19
70	30	89-106	131-163	15-20	3-6
	50	103-125	194-223	11-15	6-9
	70	118-143	257-273	11-15	9-12
	90	125-151	344-381	8-12	12-14
90	30	92-113	128-166	15-20	3-6
	50	115-143	197-233	11-15	6-9
	70	129-158	266-294	11-15	9-12
	90	150-168	354-395	8-12	12-14
110	30	96-121	125-170	55-65	2-20
	50	127-161	200-243	41-52	4-18
	70	158-200	275-315	21-38	8-19
	90	Operation not recommended			

NOTES: Operating parameters at 3 gpm/ton source and load flow. Consult the Capacity Tables for each model for normal allowable operating conditions. Some of the conditions shown above are outside of the compressor operational limits for specific models.

6/16/09

Antifreeze Correction

Catalog performance can be corrected for antifreeze use. Please use the following table and note the example given.

Antifreeze Type	Antifreeze % by wt	Heating		Cooling		Pressure Drop
		Load	Source	Load	Source	
EWT - °F [°C]		80 [26.7]	30 [-1.1]	50 [10.0]	90 [32.2]	30 [-1.1]
Water	0	1.000	1.000	1.000	1.000	1.000
Ethylene Glycol	10	0.990	0.973	0.976	0.991	1.075
	20	0.978	0.943	0.947	0.979	1.163
	30	0.964	0.917	0.921	0.965	1.225
	40	0.953	0.890	0.897	0.955	1.324
	50	0.942	0.865	0.872	0.943	1.419
Propylene Glycol	10	0.981	0.958	0.959	0.981	1.130
	20	0.967	0.913	0.921	0.969	1.270
	30	0.946	0.854	0.869	0.950	1.433
	40	0.932	0.813	0.834	0.937	1.614
	50	0.915	0.770	0.796	0.922	1.816
Ethanol	10	0.986	0.927	0.945	0.991	1.242
	20	0.967	0.887	0.906	0.972	1.343
	30	0.944	0.856	0.869	0.947	1.383
	40	0.926	0.815	0.830	0.930	1.523
	50	0.907	0.779	0.795	0.911	1.639
Methanol	10	0.985	0.957	0.962	0.986	1.127
	20	0.969	0.924	0.929	0.970	1.197
	30	0.950	0.895	0.897	0.951	1.235
	40	0.935	0.863	0.866	0.936	1.323
	50	0.919	0.833	0.836	0.920	1.399



WARNING: Gray area represents antifreeze concentrations greater than 35% by weight and should be avoided due to the extreme performance penalty they represent.

Antifreeze Correction Example

Antifreeze solution is propylene glycol 20% by weight for the source and methanol 10% for the load. Determine the corrected heating at 30°F source and 80°F load as well as pressure drop at 30°F for an O50. Also, determine the corrected cooling at 90°F source and 50°F load.

The corrected heating capacity at 30°F/80°F would be:

$$46,700 \text{ MBTUH} \times 0.913 \times 0.985 = 41,998 \text{ MBTUH}$$

The corrected cooling capacity at 90°F/50°F would be:

$$44,200 \times 0.969 \times 0.962 = 41,202 \text{ MBTUH}$$

The corrected pressure drop at 30°F and 15 GPM would be:

$$5.2 \text{ psi} \times 1.270 = 6.60 \text{ psi}$$

Troubleshooting Guideline for Refrigerant Circuit

The chart below will assist in determining if measurements taken at the unit are within factory specifications and aid in accurate diagnosis (SYMPTOM) and repair. The chart is general in nature and represents whether a symptom would result in normal, high, or low readings from the typical operating range.

Symptom	Head Pressure	Suction Pressure	Compressor Amp Draw	Superheat	Subcooling	Water Temp. Differential
Under Charged System (Possible Leak)	Low	Low	Low	High	Low	Low
Over Charged System	High	High	High	Normal	High	Normal
Low Water Flow Evaporator	Low/Normal	Low/Normal	Low	Low	High	High
Low Water Flow Condensor	High	High	High	High	Low	High
High Water Flow Evaporator	Normal	Low	Normal	High	Normal	Low
High Water Flow Condensor	Low	Low	Low	Low	High	Low
Restricted TXV (Check Service Advisory)	High	Low	Normal/Low	High	High	Low
Insufficient Compressor (Possible Bad Valves)	Low	High	Low	High	Normal/High	Low
TXV - Bulb Loss of Charge	Low	Low	Low	High	High	Low
Scaled Coaxial Heat Exchanger Evaporator	Low	Low	Low	Normal/Low	High	Low
Scaled Coaxial Heat Exchanger Condensor	High	High	High	Normal/Low	Low	Low
Restricted Filter Drier	Check temperature difference (delta T) across filter drier.					

7/8/14

HR Data

Heat of Rejection (kBtuh) Table																	
	Source EST °F	Source GPM	Load Flow-3 GPM				Load Flow-4 GPM				Load Flow-5 GPM						
			ELT 50°F	ELT 70°F	ELT 90°F	ELT 110°F	ELT 50°F	ELT 70°F	ELT 90°F	ELT 110°F	ELT 50°F	ELT 70°F	ELT 90°F	ELT 110°F			
018	30	3.0	19.8	21.3	22.7	24.2	20.1	21.5	22.8	24.2	20.4	21.6	22.9	24.2			
		4.0	19.9	21.3	22.6	23.9	20.2	21.4	22.7	23.9	20.4	21.6	22.8	24.0			
		5.0	20.0	21.2	22.4	23.6	20.2	21.4	22.5	23.7	20.4	21.5	22.7	23.8			
	50	3.0	19.6	22.6	25.6	28.6	20.0	22.9	25.8	28.8	20.5	23.3	26.1	28.9			
		4.0	19.6	22.5	25.5	28.4	20.0	22.9	25.7	28.6	20.5	23.2	25.9	28.7			
		5.0	19.7	22.5	25.4	28.2	20.0	22.8	25.6	28.3	20.4	23.1	25.8	28.5			
	70	3.0	19.3	23.9				19.9	24.4				20.6	24.9			
		4.0	19.3	23.8				19.9	24.3				20.5	24.8			
		5.0	19.3	23.8				19.9	24.2				20.4	24.7			
	90	3.0	18.4	22.7				19.0	23.2				19.5	23.6			
		4.0	18.4	22.7				19.0	23.1				19.5	23.6			
		5.0	18.5	22.7				18.9	23.1				19.4	23.5			
	110	3.0	17.6	21.5				18.0	21.9				18.4	22.3			
		4.0	17.6	21.6				18.0	22.0				18.4	22.3			
		5.0	17.6	21.6				18.0	22.0				18.4	22.4			
025	30	4.0	29.2	31.3	33.4	35.6	30.0	31.8	33.7	35.5	30.8	32.3	33.9	35.5			
		5.5	28.6	30.3	31.9	33.6	29.3	30.7	32.2	33.6	30.1	31.2	32.4	33.6			
		7.0	28.0	29.2	30.4	31.6	28.7	29.7	30.6	31.6	29.4	30.1	30.9	31.6			
	50	4.0	28.8	32.6	36.4	40.2	29.6	33.3	37.0	40.7	30.4	34.0	37.6	41.2			
		5.5	28.4	31.9	35.4	38.9	29.2	32.6	35.9	39.3	30.0	33.3	36.5	39.8			
		7.0	28.0	31.2	34.3	37.5	28.8	31.9	34.9	37.9	29.6	32.5	35.4	38.3			
	70	4.0	28.4	33.9	39.4			29.2	34.8	40.3			30.0	35.7	41.3		
		5.5	28.2	33.5	38.8			29.1	34.4	39.7			30.0	35.3	40.7		
		7.0	28.0	33.1	38.2			43.3	29.0	34.1			39.1	44.2	29.9		
	90	4.0	27.4	33.3				28.1	34.1				28.8	35.0			
		5.5	27.3	33.1				28.0	34.0				28.8	34.8			
		7.0	27.2	33.0				28.0	33.8				28.7	34.6			
	110	4.0	26.5	32.7				27.1	33.5				27.7	34.4			
		5.5	26.4	32.8				27.0	33.5				27.6	34.3			
		7.0	26.3	32.8				26.9	33.5				27.5	34.2			
040	30	5.0	43.4	41.8	40.2	38.6	44.5	42.3	40.0	37.8	45.6	42.8	39.9	37.0			
		7.5	42.2	40.4	38.6	36.7	43.1	40.8	38.5	36.2	43.9	41.2	38.5	35.7			
		10.0	41.0	38.9	36.9	34.8	41.6	39.3	37.0	34.7	42.2	39.6	37.1	34.5			
	50	5.0	41.7	46.1	50.6	55.1	43.4	47.4	51.4	55.3	45.2	48.6	52.1	55.6			
		7.5	41.0	44.8	48.6	52.3	42.6	45.9	49.2	52.5	44.2	47.1	49.9	52.7			
		10.0	40.4	43.5	46.5	49.6	41.9	44.5	47.1	49.7	43.3	45.5	47.7	49.9			
	70	5.0	39.9	50.5	61.0			42.3	52.5	62.7			44.7	54.5	64.3		
		7.5	39.8	49.2	58.6			42.2	51.1	59.9			44.5	52.9	61.3		
		10.0	39.8	48.0	56.1			64.3	42.1	49.7			57.2	64.8	44.4		
	90	5.0	38.4	48.8	59.1			40.3	50.7	61.1			42.2	52.6	63.1		
		7.5	38.3	48.1	57.9			40.1	49.9	59.7			42.0	51.8	61.6		
		10.0	38.1	47.4	56.6			40.0	49.2	58.4			41.9	51.0	60.1		
	110	5.0	36.9	47.1				38.3	48.9				39.6	50.8			
		7.5	36.7	46.9				38.1	48.8				39.5	50.7			
		10.0	36.4	46.8				37.9	48.7				39.4	50.6			

NOTE: Operation not recommended in shaded areas

4/05/2016

HR Data cont.

	Source EST °F	Source GPM	Load Flow-8 GPM				Load Flow-11.5 GPM				Load Flow-15 GPM			
			ELT 50°F	ELT 70°F	ELT 90°F	ELT 110°F	ELT 50°F	ELT 70°F	ELT 90°F	ELT 110°F	ELT 50°F	ELT 70°F	ELT 90°F	ELT 110°F
050	30	8.0	61.9	66.6	71.3	75.9	63.8	67.8	71.9	75.9	65.7	69.1	72.5	75.9
		11.5	61.1	64.6	68.1	71.6	62.8	65.7	68.6	71.5	64.5	66.9	69.2	71.5
		15.0	60.3	62.6	64.9	67.2	61.8	63.6	65.4	67.2	63.4	64.6	65.9	67.1
	50	8.0	60.2	68.7	77.3	85.9	62.2	70.4	78.5	86.7	64.2	72.0	79.8	87.5
		11.5	59.9	67.4	74.8	82.3	61.7	68.8	75.8	82.9	63.6	70.2	76.9	83.5
		15.0	59.7	66.0	72.3	78.6	61.3	67.2	73.1	76.1	63.0	68.5	74.0	79.5
	70	8.0	58.4	70.9	83.4		60.5	72.9	85.2		62.7	74.9	87.0	
		11.5	58.7	70.1	81.5		60.6	71.8	83.1		62.6	73.6	84.6	
		15.0	59.0	69.3	79.7	90.0	60.8	70.8	80.9	91.0	62.5	72.3	82.1	91.9
	90	8.0	56.4	68.2	80.0		58.1	70.0	81.9		59.9	71.8	83.7	
		11.5	56.6	67.9	79.3		58.2	69.6	81.0		59.8	71.2	82.7	
		15.0	56.8	67.7	78.6		58.2	69.2	80.1		59.7	70.7	81.6	
	110	8.0	54.3	65.5			55.7	67.1			57.1	68.7		
		11.5	54.4	65.8			55.7	67.3			57.0	68.9		
		15.0	54.5	66.1			55.7	67.5			56.9	69.0		
060	30	9.0	68.7	75.9	83.0	90.2	72.1	78.4	84.7	91.0	75.5	80.9	86.4	91.8
		13.5	67.8	73.5	79.2	84.9	71.3	76.0	80.7	85.4	74.8	78.5	82.2	85.9
		18.0	66.9	71.1	75.4	79.6	70.5	73.6	76.7	79.8	74.2	76.1	78.1	80.0
	50	9.0	67.2	78.3	89.5	100.7	70.0	80.7	91.3	102.0	72.8	83.0	93.2	103.3
		13.5	66.6	76.4	86.2	96.0	69.6	78.8	87.9	97.1	72.5	81.1	89.7	98.2
		18.0	66.1	74.5	83.0	91.4	69.2	76.9	84.6	92.2	72.2	79.2	86.2	93.1
	70	9.0	65.6	80.8	96.0		67.9	82.9	98.0		70.1	85.0	99.9	
		13.5	65.5	79.4	93.3		67.8	81.5	95.2		70.2	83.6	97.1	
		18.0	65.4	77.9	90.5	103.1	67.8	80.1	92.4	104.7	70.3	82.2	94.2	106.2
	90	9.0	62.8	77.4	92.0		64.7	79.4	94.0		66.7	81.4	96.1	
		13.5	62.7	76.5	90.4		64.6	78.6	92.5		66.6	80.6	94.6	
		18.0	62.5	75.7	88.8		64.5	77.7	90.9		66.5	79.8	93.1	
	110	9.0	60.0	74.0			61.6	75.9			63.2	77.7		
		13.5	59.9	73.7			61.5	75.6			63.0	77.5		
		18.0	59.7	73.4			61.3	75.4			62.8	77.4		
075	30	10.0	84.7	96.4	108.0	119.7	88.7	99.3	110.0	120.7	92.7	102.3	112.0	121.6
		14.5	84.4	93.8	10.3	112.6	88.2	96.6	105.0	113.4	91.9	99.4	106.8	114.2
		19.0	84.0	91.2	98.4	105.6	87.6	93.8	100.0	106.1	91.2	96.4	101.6	106.7
	50	10.0	82.3	97.2	112.0	126.8	85.9	100.2	114.5	128.8	89.4	103.1	116.9	130.7
		14.5	82.2	95.2	108.2	121.2	85.6	98.0	110.5	122.9	89.0	100.9	112.7	124.6
		19.0	82.0	93.2	104.4	115.6	85.4	95.9	106.5	117.0	88.7	98.6	108.6	118.5
	70	10.0	80.0	98.0	115.9		83.0	101.0	118.9		86.1	104.0	121.9	
		14.5	80.0	96.6	113.2		83.1	99.5	116.0		86.1	102.4	118.7	
		19.0	80.0	95.2	110.4	125.6	83.1	98.1	113.0	127.9	86.2	100.9	115.6	130.3
	90	10.0	77.4	94.8	112.2		79.9	97.3	114.8		82.4	99.9	117.4	
		14.5	77.4	93.9	110.4		79.9	96.4	112.9		82.4	98.9	115.3	
		19.0	77.0	93.0	108.6		79.9	95.4	110.9		82.5	97.9	113.3	
	110	10.0	74.9	91.6			76.8	93.7			78.7	95.8		
		14.5	74.8	91.2			76.7	93.3			78.7	95.3		
		19.0	74.7	90.8			76.7	92.8			78.7	94.9		

NOTE: Operation not recommended in shaded areas

4/05/2016

HE Data

Heat of Extraction (kBtu/h) Table															
	Source EST °F	Source GPM	Load Flow-3 GPM				Load Flow-4 GPM				Load Flow-5 GPM				
			ELT 60°F	ELT 80°F	ELT 100°F	ELT 120°F	ELT 60°F	ELT 80°F	ELT 100°F	ELT 120°F	ELT 60°F	ELT 80°F	ELT 100°F	ELT 120°F	
018	25	3.0													
		4.0													
		5.0	11.1	9.6	8.0	6.4	11.3	9.7	8.1	6.5	11.5	9.9	8.3	6.7	
	30	3.0	12.0	10.4	8.7	7.1	12.4	10.7	9.0	7.4	12.8	11.1	9.4	7.6	
		4.0	12.1	10.5	8.8	7.2	12.6	10.9	9.2	7.5	13.0	11.3	9.5	7.8	
		5.0	12.2	10.6	9.0	7.4	12.7	11.0	9.3	7.6	13.2	11.5	9.7	7.9	
	50	3.0	16.6	14.7	12.9	11.0	10.4	10.7	10.9	11.1	16.8	15.0	13.2	11.3	
		4.0	17.1	15.2	13.2	11.3	14.2	13.3	12.4	11.5	17.3	15.4	13.5	11.6	
		5.0	17.7	15.6	13.6	11.6	18.0	15.9	13.9	11.8	17.9	15.9	13.8	11.8	
	70	3.0	21.2	19.1	17.0	14.9	8.8	10.9	13.0	15.1	21.3	19.1	17.0	14.8	
		4.0	21.8	19.6	17.4	15.2	15.9	15.7	15.6	15.4	22.0	19.7	17.4	15.1	
		5.0	22.5	20.2	17.9	15.6	22.9	20.6	18.2	15.8	22.7	20.2	17.8	15.4	
	90	3.0	25.5	23.0			25.5	23.1			26.0	23.8			
		4.0	26.2	23.6			26.1	23.7			26.5	24.3			
		5.0	26.9	24.2			26.7	24.2			26.5	24.3			
025	25	4.0													
		5.5													
	30	7.0	17.0	14.7	12.4	10.1	17.2	14.9	12.7	10.4	17.4	15.1	12.9	10.6	
		4.0	17.8	15.6	13.4	11.1	18.1	15.9	13.6	11.4	18.4	16.2	13.9	11.7	
		5.5	18.4	16.1	13.7	11.4	18.7	16.4	14.1	11.7	19.0	16.7	14.4	12.1	
	50	7.0	19.1	16.6	14.1	11.6	19.3	16.9	14.5	12.1	19.6	17.2	14.8	12.5	
		4.0	24.9	22.3	19.6	17.0	25.1	22.5	19.9	17.3	25.3	22.7	20.1	17.5	
		5.5	25.9	23.2	20.4	17.6	26.1	23.4	20.6	17.9	26.3	23.6	20.9	18.2	
	70	7.0	27.0	24.0	21.1	18.1	27.1	24.2	21.3	18.4	27.2	24.4	21.6	18.8	
		4.0	32.1	29.0	25.9	22.9	32.1	29.1	26.1	23.1	32.2	29.3	26.3	23.4	
		5.5	33.4	30.2	27.0	23.7	33.5	30.3	27.2	24.0	33.5	30.4	27.3	24.3	
	90	7.0	34.8	31.4	28.0	24.6	34.8	31.5	28.2	24.8	34.8	31.6	28.3	25.1	
		4.0	39.3	35.7			39.2	35.8			39.1	35.9			
		5.5	40.8	37.0			40.3	36.8			39.8	36.7			
			7.0	42.3	38.3			41.4	37.9			40.5	37.5		
040	25	5.0													
		7.5													
	30	10.0	23.5	20.6	17.7	14.8	23.6	20.7	17.9	15.0	23.7	20.9	18.0	15.2	
		5.0	24.6	21.8	19.0	16.1	24.7	21.9	19.1	16.3	24.8	22.0	19.3	16.5	
		7.5	26.0	22.7	19.5	16.3	26.1	23.0	19.9	16.7	26.3	23.2	20.2	17.1	
	50	10.0	27.3	23.7	20.1	16.5	27.5	24.1	20.6	17.1	27.7	24.4	21.1	17.8	
		5.0	34.7	31.1	27.4	23.8	34.7	31.1	27.6	24.1	34.6	31.2	27.8	24.4	
		7.5	36.6	32.7	28.7	24.7	36.5	32.7	29.0	25.2	36.4	32.8	29.2	25.6	
	70	10.0	38.6	34.3	30.0	25.6	38.4	34.3	30.3	26.3	38.2	34.4	30.6	26.9	
		5.0	44.7	40.3	35.9	31.5	44.6	40.4	36.1	31.9	44.5	40.4	36.4	32.3	
		7.5	47.3	42.6	37.9	33.2	46.9	42.5	38.1	33.6	46.5	42.4	38.3	34.1	
	90	10.0	49.8	44.8	39.8	34.8	49.2	44.6	40.0	35.4	48.6	44.4	40.2	36.0	
		5.0	54.7	50.7			52.5	48.3			50.4	46.0			
		7.5	56.8	53.1	49.3			53.9	49.9	45.9			51.0	46.8	42.6
			10.0	58.9	55.4	51.9			55.3	51.5	47.8			51.7	47.6

NOTE: Operation not recommended in shaded areas

4/05/2016

HE Data cont.

Heat of Extraction (kBtu/h) Table															
Source EST °F	Source GPM	Load Flow-8 GPM				Load Flow-11.5 GPM				Load Flow-15 GPM					
		ELT 60°F	ELT 80°F	ELT 100°F	ELT 120°F	ELT 60°F	ELT 80°F	ELT 100°F	ELT 120°F	ELT 60°F	EL 80°F	ELT 100°F	ELT 120°F		
050	25	8.0													
		11.5													
		15.0	35.4	31.0	26.6	22.2	35.4	31.1	26.8	22.5	35.5	31.3	27.0	22.8	
	30	8.0	37.6	33.1	28.5	23.9	37.5	33.0	28.6	24.1	37.3	33.0	28.7	24.4	
		11.5	38.6	33.9	29.2	24.5	38.7	34.1	29.4	24.8	38.8	34.2	29.6	25.0	
		15.0	39.6	34.8	29.9	25.1	40.0	35.1	30.2	25.4	40.4	35.5	30.6	25.7	
	50	8.0	50.0	44.4	38.9	33.3	50.0	44.6	39.2	33.7	49.9	44.7	39.4	34.2	
		11.5	52.0	46.1	40.2	34.3	52.0	46.2	40.4	34.6	51.9	46.3	40.6	35.0	
		15.0	54.0	47.7	41.5	35.2	54.0	47.8	41.7	35.5	53.9	47.9	41.9	35.8	
	70	8.0	62.4	55.8	49.3	42.7	62.5	56.1	49.7	43.4	62.5	56.3	50.2	44.0	
		11.5	65.4	58.3	51.2	44.0	65.2	58.3	51.4	44.5	65.0	58.3	51.6	45.0	
		15.0	68.4	60.7	53.0	45.3	67.9	60.5	53.1	45.7	67.5	60.3	53.1	46.0	
	90	8.0	75.2	67.4	59.6		70.8	64.8	58.7		66.5	62.2	57.8		
		11.5	76.9	69.0	61.2		73.5	67.1	60.7		70.1	65.1	60.1		
		15.0	78.5	70.7	62.8		76.1	69.3	62.6		73.7	68.0	62.3		
060	25	9.0	Load Flow-9 GPM				Load Flow-13.5 GPM				Load Flow-18 GPM				
			ELT 60°F	ELT 80°F	ELT 100°F	ELT 120°F	ELT 60°F	ELT 80°F	ELT 100°F	ELT 120°F	ELT 60°F	ELT 80°F	ELT 100°F	ELT 120°F	
	30	13.5	38.3	33.9	29.5	25.1	38.8	34.4	30.0	25.6	39.4	35.0	30.6	26.2	
		18.0	40.1	35.9	31.7	27.5	40.7	36.5	32.3	28.0	41.4	37.1	32.8	28.6	
		9.0	42.0	37.4	32.8	28.2	42.0	37.6	33.2	28.9	42.0	37.8	33.7	29.5	
	50	13.5	44.0	39.0	34.0	29.0	43.3	38.8	34.2	29.7	42.7	38.6	34.5	30.4	
		18.0	44.0	39.0	34.0	29.0	43.3	38.8	34.2	29.7	42.7	38.6	34.5	30.4	
		9.0	55.7	50.2	44.7	39.3	56.2	50.8	45.4	40.1	56.7	51.4	46.1	40.9	
	70	13.5	58.4	52.5	46.6	40.6	58.5	52.8	47.2	41.5	58.5	53.2	47.8	42.4	
		18.0	61.1	54.7	48.4	42.0	60.7	54.8	48.9	43.0	60.4	54.9	49.4	44.0	
		9.0	71.3	64.5	57.8	51.1	71.6	65.1	58.6	52.1	72.0	65.7	59.4	53.1	
	90	13.5	74.8	67.5	60.3	53.0	74.9	68.0	61.1	54.2	75.0	68.5	61.9	55.4	
		18.0	78.3	70.5	62.7	55.0	78.2	70.9	63.6	56.3	78.0	71.2	64.4	57.6	
		9.0	86.6	78.7			84.7	78.0			82.7	77.4			
075	25	13.5	88.4	80.6	72.8		86.1	79.6	73.1		83.7	78.6	73.4		
		18.0	90.3	82.6	74.9		87.5	81.2	74.9		84.7	79.8	74.9		
		9.0	90.3	82.6	74.9		87.5	81.2	74.9		84.7	79.8	74.9		
075	30	10.0	Load Flow-10 GPM				Load Flow-14.5 GPM				Load Flow-19 GPM				
			ELT 60°F	ELT 80°F	ELT 100°F	ELT 120°F	ELT 60°F	ELT 80°F	ELT 100°F	ELT 120°F	ELT 60°F	ELT 80°F	ELT 100°F	ELT 120°F	
	50	14.5	45.5	40.0	34.5	29.0	46.0	40.6	35.1	29.7	46.5	41.1	35.7	30.3	
		19.0	47.8	42.3	36.7	31.2	48.3	42.8	37.3	31.8	48.7	43.3	37.9	32.4	
		10.0	50.1	44.1	38.1	32.1	50.5	44.6	38.7	32.8	51.0	45.2	39.4	33.5	
	70	14.5	52.3	45.9	39.5	33.1	52.8	46.5	40.2	33.9	53.3	47.1	40.8	34.6	
		19.0	52.3	45.9	39.5	33.1	52.8	46.5	40.2	33.9	53.3	47.1	40.8	34.6	
		10.0	66.7	59.6	52.5	45.4	67.3	60.3	53.3	46.4	67.8	61.0	54.2	47.3	
	90	14.5	70.1	62.4	54.8	47.2	70.5	63.1	55.7	48.2	71.0	63.7	56.5	49.3	
		19.0	73.4	65.2	57.1	48.9	73.8	65.9	58.0	50.1	74.1	66.5	58.9	51.2	
		10.0	85.6	77.0	68.3	59.7	86.3	77.8	69.4	60.9	86.9	78.7	70.4	62.2	
	075	25	14.5	90.0	80.8	71.5	62.2	90.5	81.5	72.6	63.6	91.0	82.3	73.7	65.0
			19.0	94.5	84.6	74.7	64.8	94.7	85.2	75.8	66.3	95.0	85.9	76.9	67.8
			10.0	103.9	94.4			102.2	93.7			100.4	93.1		
075	30	14.5	106.5	96.8	87.2		104.2	95.8	87.4		101.8	94.7	87.7		
		19.0	109.1	99.3	89.5		106.1	97.9	89.6		103.2	96.4	89.7		
		10.0	109.1	99.3	89.5		106.1	97.9	89.6		103.2	96.4	89.7		

NOTE: Operation not recommended in shaded areas

4/05/2016

DHW HE cont.

018 and 025 DHW Heat of Extraction (kBtuh) Table														
Source EST °F	Source GPM	Load Flow-3 GPM				Load Flow-4 GPM				Load Flow-5 GPM				
		ELT 60°F	ELT 80°F	ELT 100°F	ELT 120°F	ELT 60°F	ELT 80°F	ELT 100°F	ELT 120°F	ELT 60°F	ELT 80°F	ELT 100°F	ELT 120°F	
018	25	3.0												
		4.0												
		5.0	11.2	9.7	8.2	6.7	11.4	9.9	8.4	6.9	11.6	10.1	8.6	7.1
	30	3.0	11.9	10.4	9.0	7.5	12.1	10.6	9.2	7.7	12.3	10.8	9.3	7.8
		4.0	12.3	10.8	9.2	7.7	12.5	11.0	9.4	7.9	12.7	11.2	9.6	8.0
		5.0	12.7	11.1	9.5	7.9	12.9	11.3	9.7	8.0	13.1	11.5	9.8	8.2
	50	3.0	16.2	14.4	12.7	10.9	16.5	14.7	12.9	11.1	16.8	15.0	13.2	11.3
		4.0	16.7	14.9	13.0	11.2	17.0	15.2	13.3	11.4	17.3	15.4	13.5	11.6
		5.0	17.3	15.3	13.4	11.5	17.6	15.6	13.6	11.6	17.9	15.9	13.8	11.8
	70	3.0	20.6	18.5	16.3	14.2	20.9	18.8	16.7	14.5	21.3	19.1	17.0	14.8
		4.0	21.2	19.0	16.8	14.6	21.6	19.3	17.1	14.9	22.0	19.7	17.4	15.1
		5.0	21.9	19.6	17.3	15.0	22.3	19.9	17.6	15.2	22.7	20.2	17.8	15.4
90	3.0	24.7	22.0			24.9	22.4			25.2	22.7			
	4.0													
	5.0													
Source EST °F	Source GPM	Load Flow-4 GPM				Load Flow-5.5 GPM				Load Flow-7 GPM				
		ELT 60°F	ELT 80°F	ELT 100°F	ELT 120°F	EL 60°F	ELT 80°F	ELT 100°F	ELT 120°F	ELT 60°F	ELT 80°F	ELT 100°F	ELT 120°F	
025	25	4.0												
		5.5												
		7.0	16.8	14.6	12.5	10.3	17.0	14.9	12.9	10.9	17.1	15.2	13.3	11.4
	30	4.0	17.9	15.7	13.5	11.4	18.0	16.1	14.1	12.2	18.2	16.4	14.7	12.9
		5.5	18.4	16.2	13.9	11.7	18.6	16.5	14.3	12.2	18.8	16.8	14.8	12.7
		7.0	19.0	16.6	14.3	11.9	19.2	16.9	14.5	12.2	19.4	17.1	14.8	12.5
	50	4.0	24.4	21.7	19.0	16.2	24.7	22.1	19.5	16.9	24.9	22.4	20.0	17.6
		5.5	25.3	22.4	19.6	16.7	25.5	22.8	20.0	17.3	25.7	23.1	20.5	17.8
		7.0	26.1	23.2	20.2	17.2	26.4	23.5	20.6	17.7	26.6	23.8	21.0	18.1
	70	4.0	31.0	27.7	24.4	21.2	31.3	28.1	24.8	21.6	31.5	28.4	25.3	22.2
		5.5	32.2	28.7	25.2	21.8	32.4	29.1	25.7	22.4	32.7	29.5	26.2	23.0
		7.0	33.3	29.7	26.1	22.4	33.6	30.1	26.6	23.1	33.9	30.5	27.1	23.7
90	4.0	37.4	33.6			37.9	34.2			38.5	34.8			
	5.5													
	7.0													

NOTE: Operation not recommended in shaded areas

4/05/2016

Heating Cycle Analysis

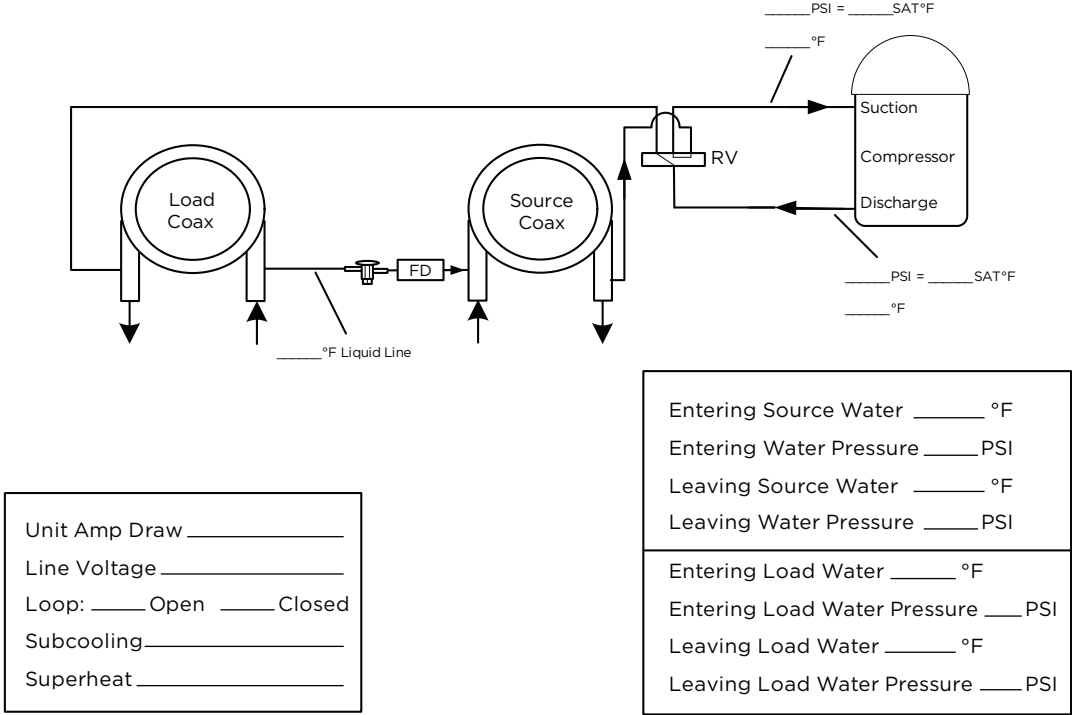

NOTE: Do not attach refrigerant gauges unless a problem is suspected!

Cooling Cycle Analysis

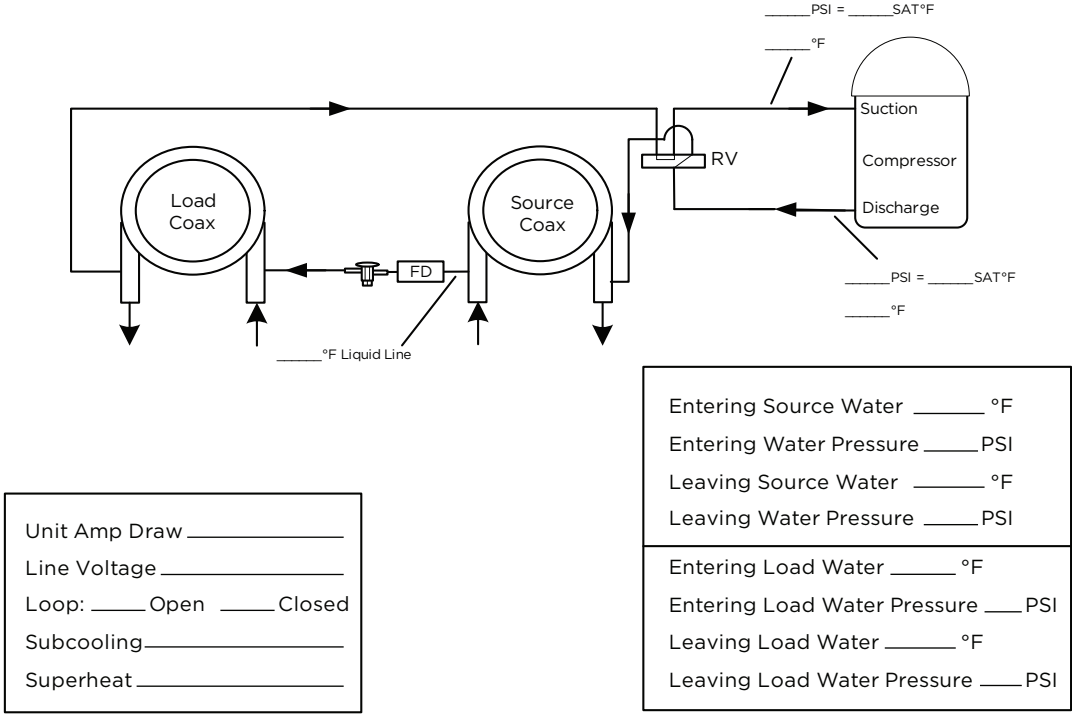

NOTE: Do not attach refrigerant gauges unless a problem is suspected!

Startup and Troubleshooting Form

Company Name: _____
 Technician Name: _____
 Model No: _____
 Owner's Name: _____
 Installation Address: _____

Company Phone No: _____
 Date: _____
 Serial No: _____
 Open or Closed Loop: _____
 Installation Date: _____

Check One

Start up/Check-out for new installation Troubleshooting Problem: _____

1. FLOW RATE IN GPM (SOURCE SIDE HEAT EXCHANGER)

Water In Pressure: a. _____ PSI
 Water Out Pressure: b. _____ PSI
 Pressure Drop = a - b c. _____ PSI
 Convert Pressure Drop to Flow Rate
 (refer to *Pressure Drop* table) d. _____ GPM

2. TEMPERATURE RISE OR DROP ACROSS SOURCE SIDE HEAT EXCHANGER

	COOLING	HEATING
Water In Temperature:	e. _____ °F	e. _____ °F
Water Out Temperature:	f. _____ °F	f. _____ °F
Temperature Difference:	g. _____ °F	g. _____ °F

3. TEMPERATURE RISE OR DROP ACROSS LOAD SIDE HEAT EXCHANGER

	COOLING	HEATING
Water In Temperature:	h. _____ °F	h. _____ °F
Water Out Temperature:	i. _____ °F	i. _____ °F
Temperature Difference:	j. _____ °F	j. _____ °F

4. HEAT OF REJECTION (HR) / HEAT OF EXTRACTION (HE) CALCULATION

HR or HE = Flow Rate x Temperature Difference x Brine Factor*
 d. (above) x g. (above) x 485 for Methanol or Environol, 500 for water*
 Heat of Extraction (Heating Mode) = _____ btu/hr
 Heat of Rejection (Cooling Mode) = _____ btu/hr
 Compare results to Capacity Data Tables

Note: Steps 5 through 8 need only be completed if a problem is suspected

5. WATTS

	COOLING	HEATING	HYDRONIC
Volts:	m. _____ VOLTS	m. _____ VOLTS	m. _____ VOLTS
Total Amps (Comp. + Fan):	n. _____ AMPS	n. _____ AMPS	n. _____ AMPS
Watts = m. x n. x 0.85	o. _____ WATTS	o. _____ WATTS	o. _____ WATTS

6. CAPACITY

Cooling Capacity = HR. - (o. x 3.413) p. _____ btu/hr
 Heating Capacity = HE. + (o. x 3.413) p. _____ btu/hr

7. EFFICIENCY

Cooling EER = p. / o. q. _____ EER
 Heating COP = p. / (o. x 3.413) q. _____ COP

8. SUPERHEAT (S.H.) / SUBCOOLING (S.C.)

	COOLING	HEATING	HYDRONIC
COOLING			
Suction Pressure:	r. _____ PSI	r. _____ PSI	r. _____ PSI
Suction Saturation Temperature:	s. _____ °F	s. _____ °F	s. _____ °F
Suction Line Temperature:	t. _____ °F	t. _____ °F	t. _____ °F
Superheat = t. - s.	u. _____ °F	u. _____ °F	u. _____ °F
HEATING			
Head Pressure:	v. _____ PSI	v. _____ PSI	v. _____ PSI
High Pressure Saturation Temp.:	w. _____ °F	w. _____ °F	w. _____ °F
Liquid Line Temperature*:	x. _____ °F	x. _____ °F	x. _____ °F
Subcooling = w. - x.	y. _____ °F	y. _____ °F	y. _____ °F

* Note: Liquid line is between the source heat exchanger and the expansion valve in the cooling mode; between the load heat exchanger and the expansion valve in the heating mode.

Troubleshooting

Should a major problem develop, refer to the following information for possible causes and corrective steps:

Compressor Won't Run

1. The fuse may be blown or the circuit breaker is open. Check electrical circuits and motor windings for shorts or grounds. Investigate for possible overloading. Replace fuse or reset circuit breakers after the fault is corrected.
2. Supply voltage may be too low. Check voltage with a volt meter.
3. Remote control system may be faulty. Check aquastat for correct wiring, setting and calibration. Check 24-volt transformer for burnout.
4. Wires may be loose or broken. Replace or tighten.
5. The low pressure switch may have tripped due to one or more of the following:
 - a. Fouled or plugged coaxial heat exchangers
 - b. Low or no water flow (source side heating, load side cooling)
 - c. Water too cold (source side heating)
 - d. Low refrigerant
6. The high pressure switch may have tripped due to one or more of the following:
 - a. Fouled or plugged coaxial heat exchanger
 - b. Low or no water flow (source side cooling, load side heating)
 - c. Water too warm (source side cooling)
7. Check the capacitor.
8. The compressor overload protection may be open. If the compressor dome is extremely hot, the overload will not reset until cooled down. If the overload does not reset when cool, it may be defective. If so, replace the compressor.

9. The internal winding of the compressor motor may be grounded to the compressor shell. If so, replace the compressor.
10. The compressor winding may be open. Check continuity with an ohm meter. If the winding is open, replace the compressor.

Insufficient Cooling or Heating

1. Check aquastat for improper location (secondary mode only).
2. Check for restriction in water flow.
3. Check subcooling for low refrigerant charge.
4. The reversing valve may be defective and creating a bypass of refrigerant. If the unit will not cool, check the reversing valve coil.
5. Check thermal expansion valve for possible restriction of refrigerant flow.

Noisy Unit Operation

1. Check compressor for loosened mounting bolts. Make sure compressor is floating free on its isolator mounts, and shipping bolt is removed from compressor plate.
2. Check for tubing contact with the compressor or other surfaces. Readjust it by bending slightly.
3. Check screws on all panels.
4. Check for chattering or humming in the contactor or relays due to low voltage or a defective holding coil. Replace the component.
5. Check for proper installation of vibration absorbing material under the unit. Unit must be fully supported, not just on corners.
6. Check for abnormally high discharge pressures.

Preventive Maintenance

1. Keep all air out of the water lines. An open loop system should be checked to ensure that the well head is not allowing air to infiltrate the water line. Lines should always be airtight.
2. Keep the system under pressure at all times. In open loop systems, it is recommended that a water control valve be placed in the discharge line to prevent loss of pressure during off cycles. Closed loop systems must have a positive static pressure.

NOTES: If the installation is performed in an area with a known high mineral content in the water, it is best to establish a periodic maintenance schedule to check the water-to-refrigerant heat exchanger on a regular basis. Should periodic cleaning be necessary, use standard cleaning procedures which are compatible with either the cupronickel or copper water lines. Generally, the more water flowing through the unit, the less chance there is for scaling. Low GPM flow rates produce higher temperatures through the coil. To avoid excessive pressure drop and the possibility of copper erosion, do not exceed GPM flow rate as shown on the specification sheets for each unit.

Cleaning Procedure

1. Close the inlet and outlet water valves to isolate the heat pump from the well system, water heater or loop pumps.
2. Disconnect piping and remove solenoid valve, pumps, etc. from the inlet and outlet connections on the heat pump.
3. Connect plastic hoses from the circulating pump* to the outlet of the water-to-refrigerant heat exchanger to be de-limed (refer to the Cleaning Connections illustration).
4. Connect a plastic hose from the circulating pump inlet to the bottom of a plastic five (5) gallon pail (refer to the Cleaning Connections illustration).
5. Connect a plastic hose from the inlet line of the water-to-refrigerant heat exchanger to the plastic pail. Secure tightly to ensure that circulating solution does not spill (refer to the Cleaning Connections illustration).
6. Partially fill the plastic pail with clear water (about two-thirds full) and prime the circulating pump. Circulate until lines are full.
7. Start the circulating pump and slowly add a commercial scale remover** to the water as recommended by the scale remover manufacturer's directions.
8. Be sure the pump circulation is opposite to the normal water flow through the water-to-refrigerant heat exchanger.
9. Maintain re-circulation until all scale and other material has been dissolved and flushed from the heat exchanger.
10. Upon completion of the procedure. Safely dispose of the solution.
11. Rinse the pump and plastic pail. Refill with clear water.
12. Start the pump circulation and flush the system until all acid residue has been removed from the system. Refill the plastic pail until only clear water is circulated.
13. Turn off the circulating pump and disconnect all hoses and fittings.
14. Replace solenoid valves, pumps, hoses and other devices in their original locations. On closed loop systems, be sure to purge between the flow center and unit to avoid getting air into the loop.
15. Put the heat pump back into operation. Check for proper operating temperature.

Cleaning Connections

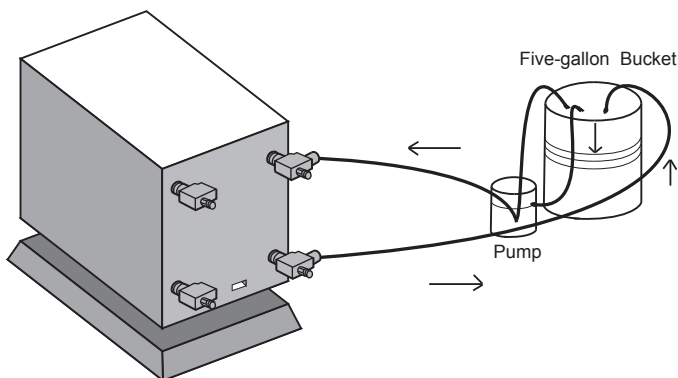

WARNING: This process involves a caustic solution and may be harmful to people and animals. Wear protective equipment (glasses, rubber gloves, apron, etc.)

NOTES: *Virginia Chemical Co. makes a Pump model H460.

* W.W. Granger Co. sells a Pump #2P-017 made by Little Giant.

**Virginia Chemical Co. makes a liquid ice machine cleaner which should be used on water-to-refrigerant heat exchangers serving a domestic hot water system. Calci-Solve by NYCO is available for use on other heat exchangers

Service Parts

Aurora Controls

Part Description		018	025	040	050	060	075
		208-230/60/1	208-230/60/1	208-230/60/1	208-230/60/1	208-230/60/1	208-230/60/1
Refrigeration Components	Compressor	34P622-01	34P583-01	34P621-01	34P580-01	34P646-01	34P614-01
	Compressor Capacitor	16P008D18	16P008D20	16P008D36	16P008D25	16P008D41	16P008D41
	Compressor Sound Jacket	92P504A05	92P504A05	92P519-01	92P519-02	92P519-02	92P519-02
	Thermal Expansion Valve	33P605-16	33P605-18	33P605-10	33P605-15	33P605-17	33P605-17
	Filter Drier for 'Reversible Models'	36P500B01	36P500B01	36P500B01	36P500B02	36P500B02	36P500B02
	Filter Drier for 'Heating Only' Models	36P510-01					
	Reversing Valve with Coil	33P506-04	33P506-04	33P503-05	33P526-05	33P526-05	33P526-05
	Hot Water Generator (Desuperheater)	n/a	n/a	62I516-03	62I516-03	62I516-03	62I516-03
	Source Coaxial Heat Exchanger (copper)	62I566-01	62I573-01	62I579-01	62I543-04	62I557-01	62I557-01
	Source Coaxial Heat Exchanger (cupronickel)	62I566-02	62I573-02	62I579-02	62I543-03	62I557-02	62I557-02
	Load Coaxial Heat Exchanger (copper)	62I566-01	62I573-01	62I579-01	62I543-04	62I557-01	62I557-01
	Load Coaxial Heat Exchanger (cupronickel)	62I566-02	62I573-02	62I579-02	62I543-03	62I557-02	62I557-02
	DHW Load Coax Vented Double Wall (copper)	62P567-01	62P549-01	n/a	n/a	n/a	n/a
Safeties / Sensors	High Pressure Switch	35P506B02	35P506B02	35P506B02	35P506B02	35P506B02	35P506B02
	Low Pressure Switch	35P506B01	35P506B01	35P506B01	35P506B01	35P506B01	35P506B01
	Discharge Pressure Transducer	35P555-01	35P555-01	35P555-01	35P555-01	35P555-01	35P555-01
	Suction Pressure Transducer	35P555-02	35P555-02	35P555-02	35P555-02	35P555-02	35P555-02
Electrical	Compressor Contactor	13P004A03	13P004A03	13P004A03	13P004A03	13P004A03	13P004A03
	Transformer	15P501-02	15P501-02	15P501-02	15P501-02	15P501-02	15P501-02
	Relay 24 VDC SPDT	13P711-01	13P711-01	13P711-01	13P711-01	13P711-01	13P711-01
	Circuit Breaker 5 Amp	19P583-01	19P583-01	19P583-01	19P583-01	19P583-01	19P583-01
	Aurora Board Programmed	17X553-10	17X553-10	17X553-10	17X553-10	17X553-10	17X553-10
	Aurora Expansion Board (AXB)	17X597-12	17X597-12	17X597-12	17X597-12	17X597-12	17X597-12
	Thermistor-Feerze Protection	12P560-06	12P560-06	12P560-06	12P560-06	12P560-06	12P560-06
	Power Block 15 amp 2 pole	12P500A01	12P500A01	12P500A01	12P500A01	12P500A01	12P500A01
	Current Transducer	12P557-01	12P557-01	12P557-01	12P557-01	12P557-01	12P557-01
	IntelliStart Soft Starter	IS1B08-16SN	IS1B08-16SN	IS1B08-16SN	IS1B16-32SN	IS1B16-32SN	IS1B16-32SN
Grounding Lug	12P004A	12P004A	12P004A	12P004A	12P004A	12P004A	
Cabinet	Front/Rear Access Panel	40P749-01	40P749-01	40P749-01	40P749-01	40P749-01	40P749-01
	Top Panel	42P557-01B	42P557-01B	42C548-01	42C548-01	42C548-01	42C548-01

3/7/2022

Notes

Revision Guide

Pages:	Description:	Date:	By:
Misc.	Updated electrical table, service parts table, and modulating water valve info.	16 Jan 2023	JM
Misc.	Update performance tables, physical data, electrical data, and schematics	10 May 2022	JM
All	NSW to 5 Series Update	08 Feb 2016	MA



Manufactured by
WaterFurnace International, Inc.
9000 Conservation Way
Fort Wayne, IN 46809
www.waterfurnace.com



IM2506WN 01/23

Product:	5 Series NSW 500W11
Type:	Geothermal Hydronic Heat Pump
Size:	1.5-6 Tons
Document:	Installation Manual