

OPERATION & MAINTENANCE

7 Series 700A11



60HZ

OMW7-0018W



 **WARNING**



WARNING: Before performing service or maintenance operations on the system, turn off main power switches to the unit. Electrical shock could cause serious personal injury.

WARNING: All products are designed, tested, and manufactured to comply with the latest publicly released and available edition of UL 60335-2-40 for electrical safety certification. All field electrical connections must follow the National Electrical Code (NEC) guide standards and / or any local codes that may be applicable for the installation.

WARNING: Only factory authorized personnel are approved for startup, check test and commissioning of this unit.

INSTALLER: Please take the time to read and understand these instructions prior to any installation. Installer must give a copy of this manual to the owner.

Definition of Warnings and Symbols

 DANGER	Indicates a situation that results in death or serious injury.
 WARNING	Indicates a situation that could result in death or serious injury.
 CAUTION	Indicates a situation that could result in minor or moderate injury.
NOTICE	Indicates a situation that could result in equipment or property damage.

For the User

 **WARNING**

This appliance is not intended for use by persons (including children) with reduced physical, sensory, or mental capabilities, or lack of experience and knowledge, unless they have been given supervision or instruction concerning use of the appliance by a person responsible for their safety.

Children should be supervised to ensure that they do not play with the appliance.

Keep this manual in a safe place in order to provide your serviceman with necessary information.

NOTICE

NOTICE: To avoid equipment damage, do not leave the system filled in a building without heat during cold weather, unless adequate freeze protection levels of antifreeze are used. Heat exchangers do not fully drain and will freeze unless protected, causing permanent damage.



Table of Contents

UNIT OVERVIEW

General Installation Information	4
Nomenclatures	6
AHRI Data	7
Physical Data	9
Dimensional Data	10
Electrical Data	12

OPERATING PRINCIPLES

Auxiliary Heat Ratings	13
Auxiliary Heat Electrical Data	13
Blower Performance Data	14
Antifreeze Corrections	15
Correction Factor Tables	16
Heat of Extraction/Heat of Rejection	17
Water Quality	18
Operating Parameters	19
Pressure Drop	20
Operation Logic	21
Aurora Controls Operation	22
Refrigerant Circuit Guideline	34
Electrical Information	35
Electronic Thermostat Installation	36
Electrical Information Flow Centers	37

SERVICE AND TROUBLESHOOTING

Closed Loop Ground Source Systems	41
Open Loop Ground Water Systems	43
Compressor and Thermistor Resistance	44
Reference Calculations and Legend	45
Operating Limits	46
Preventative Maintenance	47
Replacement Procedures	47
Troubleshooting	48
Aurora Interface Diagnostic (AID) Tool	49
Preliminary Checkout Procedure	49
Aurora Fault/Alarm Codes	50
Troubleshooting Checklist	53
Control Board Troubleshooting Steps	53
Control Board Troubleshooting Flow Charts	56
Communicating Thermostat Troubleshooting Guide	66
Control Board Signals	70
Jumping the Control Board	73
Troubleshooting	74
Performance Data	76
Service Parts List	87
Decommissioning	89
Refrigerant Recovery	90
Refrigerant Removal and Evacuation	90
Charging Procedures	91

REVISION GUIDE	93
---------------------------------	-----------

General Installation Information

NOTICE: Do not store or install units in corrosive environments or in locations subject to temperature or humidity extremes. Corrosive conditions and high temperature or humidity can significantly reduce performance, reliability, and service life.

NOTICE: A minimum of 24 in. clearance should be allowed for access to front access panel.

NOTICE: To avoid equipment damage, DO NOT use these units as a source of heating or cooling during the construction process. The mechanical components and filters can quickly become clogged with construction dirt and debris, which may cause system damage and void product warranty.

For the Installer

If you are NOT sure how to install or operate the unit, contact your dealer.

Installing and servicing air conditioning and heating equipment can be hazardous due to system pressure and electrical components. Only trained and qualified service personnel should install, repair or service heating and air conditioning equipment. When working on heating and air conditioning equipment, observe precautions in the literature, tags and labels attached to the unit and other safety precautions that may apply.

This manual contains specific information about the required qualification of the working personnel for maintenance, service and repair operations. Every working procedure that affects safety means shall only be carried out by competent persons.

Examples for such working procedures are:

- breaking into the refrigerating circuit;
- opening of sealed components or ventilated enclosures.

Follow all safety codes. Wear safety glasses and work gloves. Use quenching cloth for brazing operations. Have fire extinguisher available for all brazing operations. Follow all procedures to remain in compliance with national gas regulations.

Prior to beginning work on systems containing FLAMMABLE REFRIGERANTS, safety checks are necessary to ensure that the risk of ignition is minimized. Work shall be undertaken under a controlled procedure so as to minimise the risk of a flammable gas or vapor being present while the work is being performed. All maintenance staff and others working in the local area shall be instructed on the nature of work being carried out. Work in confined spaces shall be avoided.

The area shall be checked with an appropriate refrigerant detector prior to and during work, to ensure the technician is aware of potentially toxic or flammable atmospheres. Ensure that the leak detection equipment being used is suitable for use with all applicable refrigerants, i.e. non-sparking, adequately sealed or intrinsically safe.

If any hot work is to be conducted on the refrigerating equipment or any associated parts, appropriate fire extinguishing equipment shall be available to hand. Have a dry powder or CO2 fire extinguisher adjacent to the charging area.

No person carrying out work in relation to a REFRIGERATING SYSTEM which involves exposing any pipe work shall use any sources of ignition in such a manner that it may lead to the risk of fire or explosion. All possible ignition sources, including cigarette smoking, should be kept sufficiently far away from the site of installation, repairing, removing and disposal, during which refrigerant can possibly be released to the surrounding space. Prior to work taking place, the area around the equipment is to be surveyed to make sure that there are no flammable hazards or ignition risks. "No Smoking" signs shall be displayed.

Where electrical components are being changed, they shall be fit for the purpose and to the correct specification. At all times the manufacturer's maintenance and service guidelines shall be followed. If in doubt, consult the manufacturer's technical department for assistance.

The following checks shall be applied to installations using FLAMMABLE REFRIGERANTS:

- the actual REFRIGERANT CHARGE is in accordance with the room size within which the refrigerant containing parts are installed;
- the ventilation machinery and outlets are operating adequately and are not obstructed;
- if an indirect refrigerating circuit is being used, the secondary circuit shall be checked for the presence of refrigerant;
- marking to the equipment continues to be visible and legible. Markings and signs that are illegible shall be corrected;
- refrigerating pipe or components are installed in a position where they are unlikely to be exposed to any substance which may corrode refrigerant containing components, unless the components are constructed of materials which are inherently resistant to being corroded or are suitably protected against being so corroded.

Instructions for Equipment Using R-454B Refrigerant

WARNING

- **Do NOT pierce or burn**
- **Do NOT use means to accelerate the defrosting process or to clean the equipment, other than those recommended by the manufacturer**
- **Be aware that refrigerants may not contain an odor**

WARNING

- **The Appliance should be stored so as to prevent mechanical damage and in a room without continuously operating ignition sources (example: open flames, an operating gas appliance or an operating electric heater)**

General Installation Information

⚠ WARNING

Ventilated Area: ensure that the area is in the open or that it is adequately ventilated before breaking into the system of conducting any hot work. A degree of ventilation should continue during the period that the work is carried out. The ventilation should safely disperse any released refrigerant and preferably expel it. Keep ventilation area clear of obstructions!

⚠ WARNING

Do NOT use potential sources of ignition in searching for or detection of refrigerant leaks. A halide torch (or any other detector using a naked flame) shall not be used.

The following leak detection methods are deemed acceptable for all refrigerant systems. Electronic leak detectors may be used to detect refrigerant leaks but, in the case of FLAMMABLE REFRIGERANTS, the sensitivity may not be adequate, or may need re-calibration. (Detection equipment shall be calibrated in a refrigerant-free area.) Ensure that the detector is not a potential source of ignition and is suitable for the refrigerant used. Leak detection equipment shall be set at a percentage of the LFL of the refrigerant and shall be calibrated to the refrigerant employed, and the appropriate percentage of gas (25 % maximum) is confirmed. Leak detection fluids are also suitable for use with most refrigerants but the use of detergents containing chlorine shall be avoided as the chlorine may react with the refrigerant and corrode the copper pipe-work. NOTE Examples of leak detection fluids are bubble method, fluorescent method agents If a leak is suspected, all naked flames shall be removed/extinguished. If a leakage of refrigerant is found which requires brazing, all of the refrigerant shall be recovered from the system, or isolated (by means of shut off valves) in a part of the system remote from the leak. Removal of refrigerant shall follow the procedure outlined in this manual.

Installation Site

This equipment has been evaluated to be installed up to a maximum altitude of 3000m (9843ft) and should not be installed at an altitude greater than 3000m. For installation only in locations not accessible to the general public.

⚠ WARNING

For appliances using A2L refrigerants connected via an air duct system to one or more rooms, only auxiliary devices approved by the appliance manufacturer or declared suitable with the refrigerant shall be installed in connecting ductwork. The manufacturer shall list in the instructions all approved auxiliary devices by manufacturer and model number for use with the specific appliance, if those devices have a potential to become an ignition source.

Installation Space Requirements

NOTE: Equipment with refrigerant charge less than 64 oz does not require have a minimum floor area requirement and does not require a refrigerant leak detection sensor. The sensor might be added as a feature.

⚠ WARNING

Equipment containing R-454B refrigerant shall be installed, operated, and stored in a room with floor area larger than the area defined in the “Minimum Floor Area” chart based on the total refrigerant charge in the system. This requirement applies to indoor equipment with or without a factory refrigerant leakage sensor.

⚠ CAUTION

It is not recommended to use a potable water source for this equipment water supply.

⚠ WARNING

This equipment comes with a factory installed Refrigerant Detection Device which is capable of determining it’s specified end-of-life and replacement instructions. Refrigerant sensors for refrigerant detection systems shall only be replaced with sensors specified by the appliance manufacture.

⚠ WARNING

Take sufficient precautions in case of refrigerant leakage. If refrigerant gas leaks, ventilate the area immediately.
POSSIBLE RISKS: Excessive refrigerant concentrations in a closed room can lead to oxygen deficiency

⚠ WARNING

ALWAYS recover the refrigerant. Do NOT release them directly into the environment. Follow handling instructions carefully in compliance with national regulations.

⚠ WARNING

Check that cabling will not be subject to wear, corrosion, excessive pressure, vibration, sharp edges or any other adverse environmental effects. The check shall also take into account the effects of aging or continual vibration from sources such as compressors or fans.

Nomenclature

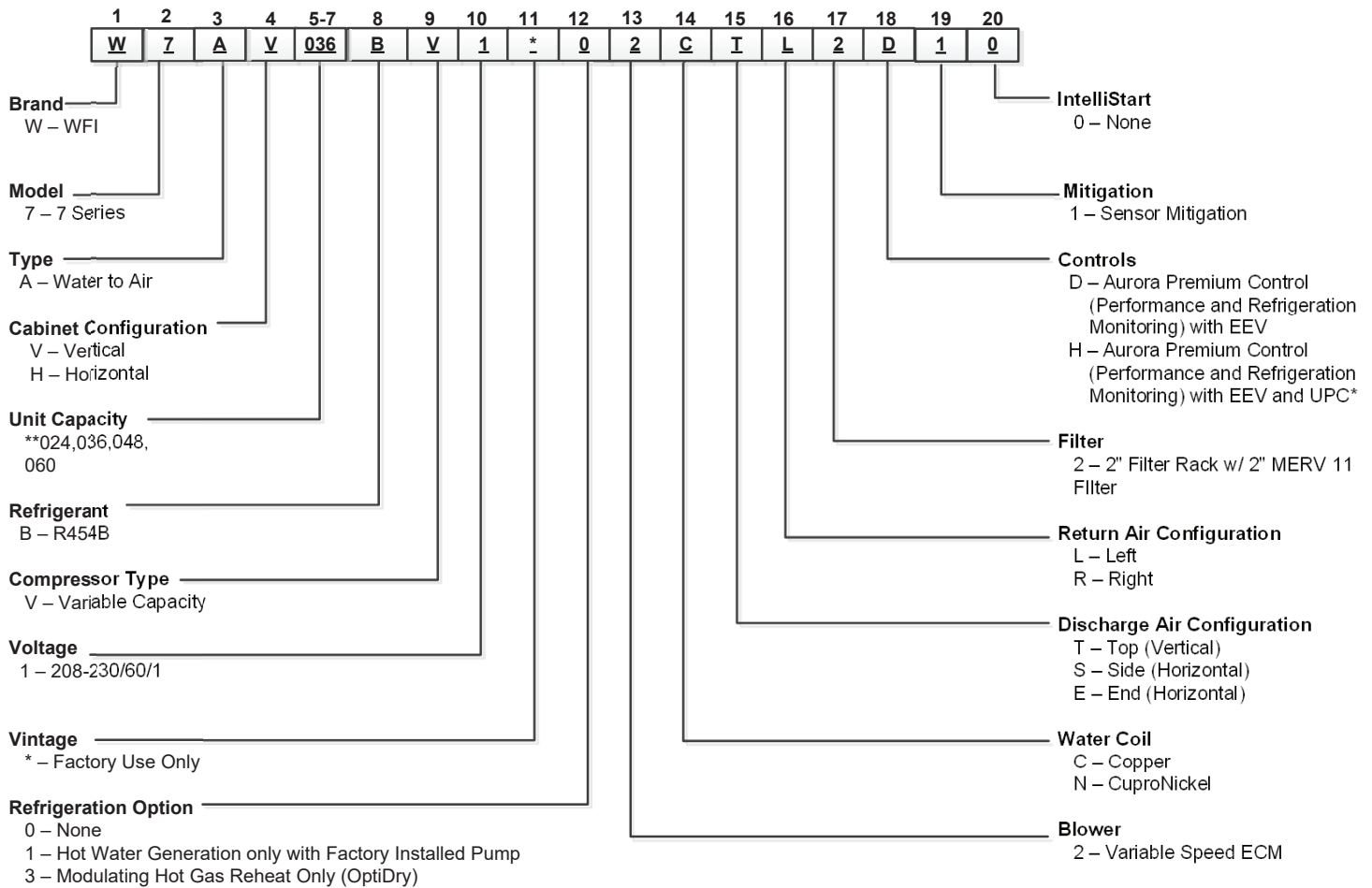

Rev.: 5/16/24

*UPC is not compatible with Symphony or IntelliZone2.

**024 model not available with OptiDry

AHRI Data

The performance standard AHRI/ASHRAE/ISO 13256-1 became effective January 1, 2000 and replaces ARI Standards 320, 325, and 330. This new standard has three major categories: Water Loop (comparable to ARI 320), Ground Water (ARI 325), and Ground Loop (ARI 330). Although these standards are similar there are some differences:

Unit of Measure: The Cooling COP

The cooling efficiency is measured in EER (US version measured in Btu/h per Watt. The Metric version is measured in a cooling COP (Watt per Watt) similar to the traditional COP measurement.

Water Conditions Differences

Entering water temperatures have changed to reflect the centigrade temperature scale. For instance the water loop heating test is performed with 68°F (20°C) water rounded down from the old 70°F (21.1°C).

Air Conditions Differences

Entering air temperatures have also changed (rounded down) to reflect the centigrade temperature scale. For instance the cooling tests are performed with 80.6°F (27°C) dry bulb and 66.2°F (19°C) wet bulb entering air instead of the traditional 80°F (26.7°C) DB and 67°F (19.4°C) WB entering air temperatures. 80.6/66.2 data may be converted to 80/67 using the entering air correction table. This represents a significantly lower relative humidity than the old 80/67 of 50% and will result in lower latent capacities.

Pump Power Correction Calculation

Within each model, only one water flow rate is specified for all three groups and pumping Watts are calculated using the following formula. This additional power is added onto the existing power consumption.

- Pump power correction = (gpm x 0.0631) x (Press Drop x 2990) / 300
Where 'gpm' is waterflow in gpm and 'Press Drop' is the pressure drop through the unit heat exchanger at rated water flow in feet of head.

Blower Power Correction Calculation

Blower power is corrected to zero external static pressure using the following equation. The nominal airflow is rated at a specific external static pressure. This effectively reduces the power consumption of the unit and increases cooling capacity but decreases heating capacity. These Watts are significant enough in most cases to increase EER and COPs fairly dramatically over ARI 320, 325, and 330 ratings.

- Blower Power Correction = (cfm x 0.472) x (esp x 249) / 300
Where 'cfm' is airflow in cfm and 'esp' is the external static pressure at rated airflow in inches of water gauge.

ISO Capacity and Efficiency Calculations

The following equations illustrate cooling calculations:

- ISO Cooling Capacity = Cooling Capacity (Btu/h) + (Blower Power Correction (Watts) x 3.412)
- ISO EER Efficiency (W/W) = ISO Cooling Capacity (Btu/h) x 3.412 / [Power Input (Watts) - Blower Power Correction (Watts) + Pump Power Correction (Watt)]

The following equations illustrate heating calculations:

- ISO Heating Capacity = Heating Capacity (Btu/h) - (Blower Power Correction (Watts) x 3.412)
- ISO COP Efficiency (W/W) = ISO Heating Capacity (Btu/h) x 3.412 / [Power Input (Watts) - Blower Power Correction (Watts) + Pump Power Correction (Watt)]

Comparison of Test Conditions

	ARI 320	ISO/AHRI 13256-1 WLHP	ARI 325	ISO/AHRI 13256-1 GWHP	ARI 330	ISO/AHRI 13256-1 GLHP
Cooling						
Entering Air - DB/WB °F	80/67	80.6/66.2	80/67	80.6/66.2	80/67	80.6/66.2
Entering Water - °F	85	86	50/70	59	77	77
Fluid Flow Rate	*	**	**	**	**	**
Heating						
Entering Air - DB/WB °F	70	68	70	68	70	68
Entering Water - °F	70	68	50/70	50	32	32
Fluid Flow Rate	*	**	**	**	**	**

NOTES: * Flow rate is set by 10°F rise in standard cooling test

** Flow rate is specified by the manufacturer

Part load entering water conditions not shown

WLHP = Water Loop Heat Pump; GWHP = Ground Water Heat Pump; GLHP = Ground Loop Heat Pump

Conversions:

Airflow (lps) = cfm x 0.472;

WaterFlow (lps) = gpm x 0.0631;

ESP (Pascals) = ESP (in wg) x 249;

Press Drop (Pascals) = Press Drop (ft hd) x 2990

AHRI Data

Variable Speed Residential AHRI Data

ECM Motor
 AHRI/ASHRAE/ISO 13256-1
 English (IP) Units

Model	Capacity Modulation	Flow Rate Clg/Htg	Water Loop Heat Pump				Ground Water Heat Pump				Ground Loop Heat Pump			
			Cooling EWT 86°F		Heating EWT 68°F		Cooling EWT 59°F		Heating EWT 50°F		Cooling Full Load 77°F Part Load 68°F		Heating Full Load 32°F Part Load 41°F	
		cfm	Capacity Btuh	EER Btuh/W	Capacity Btuh	COP	Capacity Btuh	EER Btuh/W	Capacity Btuh	COP	Capacity Btuh	EER Btuh/W	Capacity Btuh	COP
024	Full	850/1150	22,200	16.9	39,200	6.0	26,300	37.8	32,100	5.0	24,100	23.6	24,800	4.1
	Part		9,300	21.5	13,500	8.4	11,900	57.4	10,100	6.0	13,400	41.0	12,400	5.1
036	Full	1300/1500	33,500	15.3	51,800	5.4	38,200	28.7	41,900	4.7	35,800	18.1	32,900	3.8
	Part		11,900	20.4	17,000	7.9	11,400	51.6	14,000	5.9	13,400	41.0	12,400	5.1
048	Full	1500/1800	41,500	16.0	66,000	4.8	49,000	27.4	54,500	4.2	45,000	18.9	42,000	3.6
	Part		20,000	24.0	23,200	7.8	19,000	56.0	19,000	6.1	15,600	47.0	16,900	5.1
060	Full	1800/2200	50,000	15.3	79,800	4.7	60,700	23.4	66,000	4.3	56,000	17.1	51,700	3.5
	Part		20,400	23.7	28,300	8.0	27,000	54.2	22,100	5.9	22,700	42.0	19,400	5.2

Cooling capacities based upon 80.6°F DB, 66.2°F WB entering air temperature
 Heating capacities based upon 68°F DB, 59°F WB entering air temperature
 All ratings based upon 208V operation

6/13/24

Energy Star Compliance Table

Model	Tier 3	
	Ground Water	Ground Loop
024	E	E
036	E	E
048	E	E
060	E	E

5/14/24

Energy Star Rating Criteria

In order for water-source heat pumps to be Energy Star rated they must meet or exceed the minimum efficiency requirements listed below. Tier 3 represents the current minimum efficiency water source heat pumps must have in order to be Energy Star rated.

Tier 3: 1/1/2012 - No Effective End Date Published		
	EER	COP
Water-to-Air		
Ground Loop	17.1	3.6
Ground Water	21.1	4.1
Water-to-Water		
Ground Loop	16.1	3.1
Ground Water	20.1	3.5



Physical Data

Model		024	036	048	060
Compressor (1 each)		Variable Speed Scroll			
Factory Charge R454B, oz [kg]	Vertical	64 [1.81]	64 [1.81]	95 [2.69]	110 [3.12]
Factory Charge R454B, oz [kg]	Horizontal	60 [1.70]	60 [1.70]	91 [2.58]	118 [3.35]
Factory Charge R454B, oz [kg]	Vertical MHGR Only	n/a	66 [1.87]	97 [2.75]	112 [3.18]
Factory Charge R454B, oz [kg]	Horizontal MHGR Only	n/a	62 [1.76]	93 [2.64]	120 [3.40]
ECM Blower Motor & Blower		Variable Speed			
Blower Motor Type/Speeds	ECM				
Blower Motor- hp [W]	ECM	1/2 [373]	1/2 [373]	1 [746]	1 [746]
High Static Blower Motor - hp [W]	ECM	1 [746]	1 [746]	n/a	n/a
Blower Wheel Size (Dia x W), in. [mm]	ECM	11 x 10 [279 x 254]	11 x 10 [279 x 254]	11 x 10 [279 x 254]	11 x 10 [279 x 254]
High Static Blower Wheel Size - [Dia. x W], in. [mm]	ECM	11 x 10 [279 x 254]	11 x 10 [279 x 254]	n/a	n/a
Coax and Water Piping					
Water Connections Size - Swivel - in [mm]		1" [25.4]	1" [25.4]	1" [25.4]	1" [25.4]
HWG Connection Size - Stub - in [mm]		1/2" [12.7]	1/2" [12.7]	1/2" [12.7]	1/2" [12.7]
Coax & Piping Water Volume - gal [l]		1.3 [4.9]	1.3 [4.9]	2.3 [8.7]	2.3 [8.7]
Vertical					
Air Coil Dimensions (H x W), in. [mm]		32 x 25 [813 x 635]	32 x 25 [813 x 635]	32 x 25 [813 x 635]	36 x 25 [914 x 635]
Air Coil Total Face Area, ft ² [m ²]		5.6 [0.570]	5.6 [0.570]	5.6 [0.570]	6.3 [0.641]
Air Coil Tube Size, in [mm]		3/8 [9.5]	3/8 [9.5]	3/8 [9.5]	3/8 [9.5]
Air Coil Number of rows		3	3	3	4
Reheat Coil Dimensions (H x W), in. [mm] (MHGR Only)		23 x 30 [584 x 762]	23 x 30 [584 x 762]	23 x 30 [584 x 762]	23 x 34 [584 x 864]
Filter Standard - 2" [51mm] Pleated MERV11 Throwaway, in [mm]		32 x 30 [813 x 762]	32 x 30 [813 x 762]	32 x 30 [813 x 762]	36 x 30 [914 x 762]
Weight - Operating, lb [kg]		331 [150]	331 [150]	354 [161]	372 [169]
Weight - Packaged, lb [kg]		351 [159]	351 [159]	374 [170]	392 [178]
Weight - Operating, lb [kg] (MHGR Only)		n/a	382 [173]	418 [190]	444 [201]
Weight - Packaged, lb [kg] (MHGR Only)		n/a	402 [182]	438 [199]	464 [210]
Horizontal					
Air Coil Dimensions (H x W), in. [mm]		20 x 40 [508 x 1016]	20 x 40 [508 x 1016]	20 x 40 [508 x 1016]	20 x 45 [508 x 1143]
Air Coil Total Face Area, ft ² [m ²]		5.6 [0.570]	5.6 [0.570]	5.6 [0.570]	6.3 [0.641]
Air Coil Tube Size, in [mm]		3/8 [9.5]	3/8 [9.5]	3/8 [9.5]	3/8 [9.5]
Air Coil Number of rows		3	3	3	4
Reheat Coil Dimensions (H x W), in. [mm] (MHGR Only)		18 x 33 [457 x 838]	18 x 33 [457 x 838]	18 x 33 [457 x 838]	18 x 38 [457 x 965]
Filter Standard - 2" [51mm] Pleated MERV11 Throwaway, in [mm]		1 - 20 x 20 [508 x 508] 1 - 20 x 22 [508 x 559]	1 - 20 x 20 [508 x 508] 1 - 20 x 22 [508 x 559]	1 - 20 x 20 [508 x 508] 1 - 20 x 22 [508 x 559]	1 - 20 x 25 [508 x 635] 1 - 20 x 22 [508 x 559]
Weight - Operating, lb [kg]		365 [166]	365 [166]	388 [176]	402 [182]
Weight - Packaged, lb [kg]		395 [179]	395 [179]	418 [190]	432 [196]
Weight - Operating, lb [kg] (MHGR Only)		n/a	387 [176]	452 [205]	494 [224]
Weight - Packaged, lb [kg] (MHGR Only)		n/a	407 [185]	482 [219]	514 [233]

Dimensional Data - Vertical

Top Air Discharge

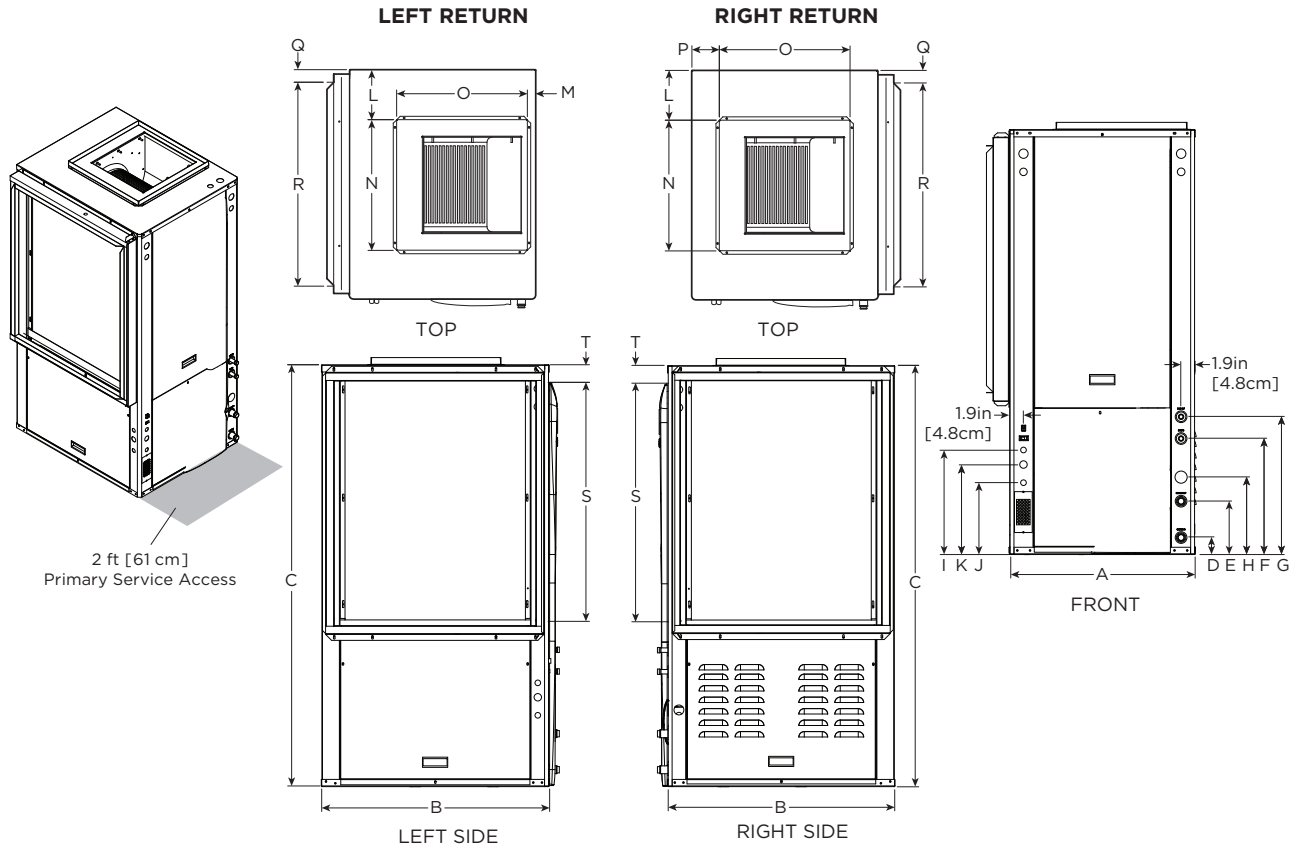

Vertical Top Flow Model	Overall Cabinet			Water Connections								Electrical Connections			Discharge Connection duct flange installed (± 0.10 in.)					Return Connection using std deluxe filter rack (± 0.10)			
	A	B	C	D	E	F	G	H	Loop Water FPT	HWG (O.D.)	I	J	K	L	M	N	O	P	Q	R	S	T	
	Width	Depth	Height	Loop In	Loop Out	HWG In	HWG Out	Condensate			1/2" cond Low Voltage	1/2" cond Ext Pump	3/4" cond Power Supply	Supply Width	Supply Depth	Supply Width	Supply Depth	Return Depth	Return Height	Return Depth	Return Height		
024-036	in.	25.6	31.6	54.4	2.3	7.3	15.9	18.9	10.6	1"	1/2"	14.3	9.8	12.3	6.9	1.1	18.0	18.0	3.8	1.7	28.1	30.0	1.7
	cm.	65.0	80.3	138.2	5.8	18.5	40.4	48.0	26.9	Swivel	Stub	36.3	24.9	31.2	17.5	2.8	45.7	45.7	9.7	4.3	71.4	76.2	4.3
048	in.	25.6	31.6	54.4	2.3	7.3	15.9	18.9	10.6	1"	1/2"	14.3	9.8	12.3	6.9	1.1	18.0	18.0	3.8	1.7	28.1	30.0	1.7
	cm.	65.0	80.3	138.2	5.8	18.5	40.4	48.0	26.9	Swivel	Stub	36.3	24.9	31.2	17.5	2.8	45.7	45.7	9.7	4.3	71.4	76.2	4.3
060	in.	25.6	31.6	58.4	2.3	7.3	15.9	18.9	10.6	1"	1/2"	14.3	9.8	12.3	6.9	1.1	18.0	18.0	3.8	1.7	28.1	34.0	1.7
	cm.	65.0	80.3	148.3	5.8	18.5	40.4	48.0	26.9	Swivel	Stub	36.3	24.9	31.2	17.5	2.8	45.7	45.7	9.7	4.3	71.4	86.4	4.3

Condensate is 3/4" PVC female glue socket and is switchable from side to front
 Unit shipped with deluxe 2" (field adjustable to 1") duct collar/filter rack extending from unit 3.25" and is suitable for duct connection.
 Discharge flange is field installed and extends 1" [25.4mm] from cabinet
 Decorative molding and/or water connections extend 1.2" [30.5mm] beyond front of cabinet.
 Louvered vents in the compressor section right side access panel extend 1/2" [12.7 mm] from side of cabinet. Allow clearance for venting.

05/10/24

Dimensional Data - Horizontal

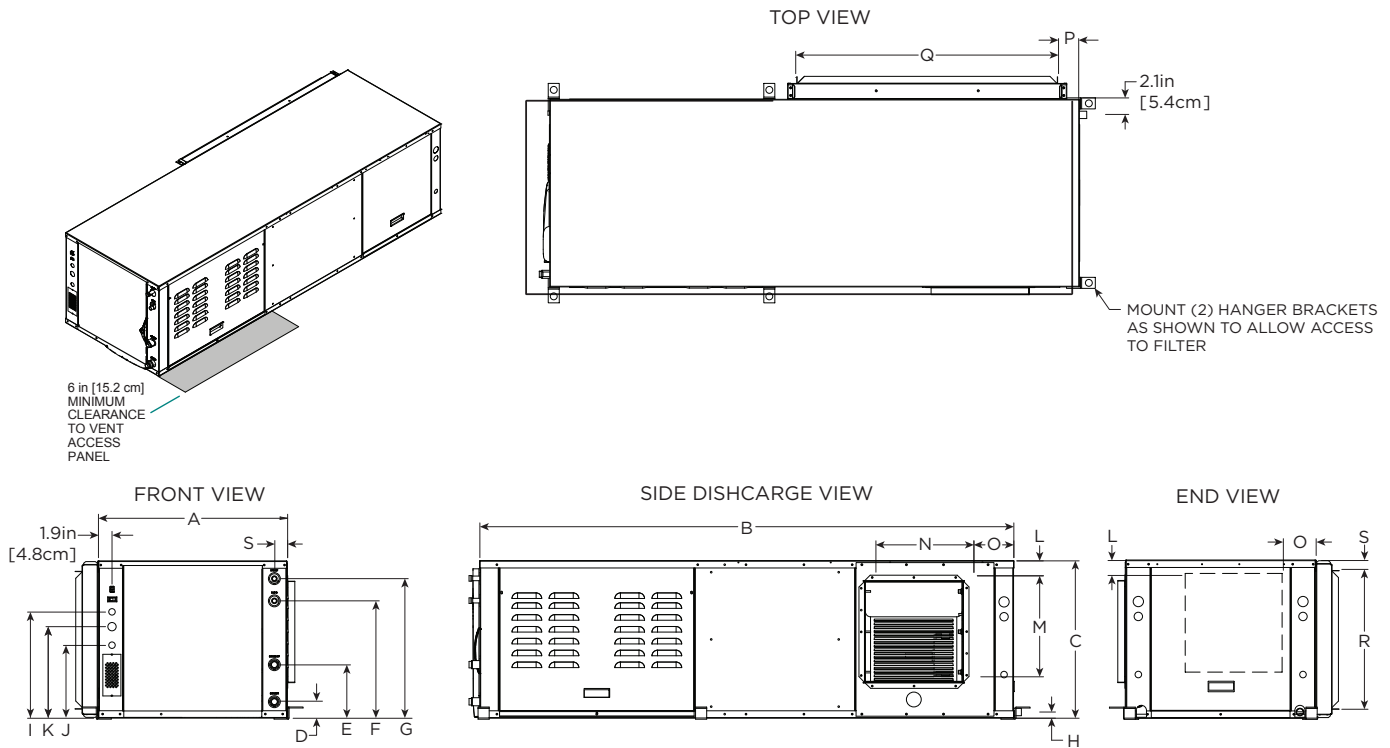

AS SHOWN LR UNIT (RR UNIT ON OPPOSITE SIDE—SAME DIMENSIONS)

Horizontal Models	Overall Cabinet			Water Connections								Electrical Connections			Discharge Connection duct flange installed (± 0.10 in.)				Return Connection using std deluxe filter rack (± 0.10)			
	A	B	C	D	E	F	G	H	Loop Water FPT	HWG Sweat (O.D.)	I	J	K	L	M	N	O	P	Q	R	S	
	Width	Depth	Height	In	Out	HWG In	HWG Out	Condensate			1/2" cond	1/2" cond	3/4" cond		Supply Height	Supply Depth			Return Depth	Return Height		
024-036	in.	25.6	77.0	21.3	2.3	7.3	15.9	18.9	0.8	1" Swivel	1/2" Stub	14.3	9.8	12.3	SEE CHART	13.6	13.2	SEE CHART	2.8	40.4	18.9	1.3
	cm.	65.0	195.6	54.1	5.8	18.5	40.4	48.0	2.0			36.3	24.9	31.2		34.5	33.5		7.1	102.6	48.0	3.3
048	in.	25.6	77.0	21.3	2.3	7.3	15.9	18.9	0.8	1" Swivel	1/2" Stub	14.3	9.8	12.3	SEE CHART	13.6	13.2	SEE CHART	2.8	40.4	18.9	1.3
	cm.	65.0	195.6	54.1	5.8	18.5	40.4	48.0	2.0			36.3	24.9	31.2		34.5	33.5		7.1	102.6	48.0	3.3
060	in.	25.6	82.0	21.3	2.3	7.3	15.9	18.9	0.8	1" Swivel	1/2" Stub	14.3	9.8	12.3	SEE CHART	13.6	13.2	SEE CHART	2.8	45.4	18.9	1.3
	cm.	65.0	208.3	54.1	5.8	18.5	40.4	48.0	2.0			36.3	24.9	31.2		34.5	33.5		7.1	115.3	48.0	3.3

Condensate is 3/4" PVC female glue socket and is switchable from side to front

5/10/24

Unit shipped with deluxe 2" (field adjustable to 1") duct collar/filter rack extending from unit 3.25" and is suitable for duct connection.

Discharge flange is field installed and extends 1" [25.4mm] from cabinet

Decorative molding and/or water connections extend 1.2" [30.5mm] beyond front of cabinet.

Louvered vents in the compressor section right side access panel extend 1/2" [12.7 mm] from side of cabinet. Allow clearance for venting.

Units Not Shown Above	L	O	
Right Return End Discharge	in	2.8	4.6
	cm	7.1	11.8
Right Return Side Discharge	in	4.9	6.9
	cm	12.4	17.5
Left Return End Discharge	in	4.9	7.6
	cm	12.4	19.4
Left Return Side Discharge	in	2.8	6.9
	cm	7.1	17.5

Electrical Data

Model	Rated Voltage	Voltage Min/Max	COMP MRC	COMP MOC	Drive RLA	Drive Internal Fuse	HWG Pump FLA	Ext Loop FLA	Blower Motor FLA	Total Unit FLA	Minimum Circuit Amp	Max Fuse HACR Breaker
024-036	208-230/60/1	187/253	22.0	17.0	22.0	30.0	0.4	5.4	4.0	31.8	37.3	40
*036	208-230/60/1	187/253	22.0	17.0	22.0	30.0	0.4	5.4	7.0	34.8	40.3	45
048	208-230/60/1	187/253	28.0	22.0	28.0	35.0	0.4	5.4	7.0	40.8	47.8	50
060	208-230/60/1	187/253	33.0	27.0	33.0	40.0	0.4	5.4	7.0	45.8	54.1	60

*With optional 1 HP ECM motor
 Rated Voltage of 208/230/60/1
 HACR circuit breaker in USA only
 All fuses Class RK-5

Auxiliary Heat Ratings

Model	KW		Stages	BTU/HR		Min CFM	Variable Speed Compatibility		
	208V	230V		208V	230V		024-036	048	060
EAL(H)10	7.2	9.6	2	24,600	32,700	1100	•	•	•
EAL(H)15	10.8	14.4	3	36,900	49,100	1250	•	•	•
EAL(H)20	14.4	19.2	4	49,200	65,500	1500		•	•

Air flow level for auxiliary heat (Aux) must be above the minimum cfm in this table
 Order the "H" part number when installed on horizontal and vertical rear discharge units

5/10/24

Auxiliary Heat Electrical Data

Model	Supply Circuit	Heater Amps		Min Circuit Amp		Max Fuse (USA)		Max Fuse (CAN)		Max CKT BRK	
		208 V	240 V	208 V	240 V	208 V	240 V	208 V	240 V	208 V	240 V
EAL(H)10*	Single	34.7	40	53.3	60	60	60	60	60	60	60
EAL(H)15*	Single	52.0	60	75	85	80	90	80	90	70	100
	L1/L2	34.7	40	53.3	60	60	60	60	60	60	60
	L3/L4	17.3	20	21.7	25	25	25	25	25	20	30
EAL(H)20*	Single	69.3	80	96.7	110	100	110	100	110	100	100
	L1/L2	34.7	40	53.3	60	60	60	60	60	60	60
	L3/L4	34.7	40	43.3	50	45	50	45	50	40	50

All heaters rated single phase 60 cycle and include unit fan load
 All fuses type "D" time delay (or HACR circuit breaker in USA)

11/30/17

Blower Performance Data

Variable Speed Air Flow

Model	Max ESP	Speed 1	Speed 2	Speed 3	Speed 4	Speed 5	Speed 6	Speed 7	Speed 8	Speed 9	Speed 10	Speed 11	Speed 12
024***	0.50	285	380 G	525 L	675	815	980	1100 H	1220 Aux				
036	0.50	285	380 G	525 L	675	815	980	1100	1220	1330	1440 H	1540 Aux	1575
036 w/1hp*	0.75	480	565 G	665 L	761	870	1000	1100	1200	1300	1410 H	1520 Aux	1630
048	0.75	475	620 G	730 L	850	1020	1140	1270	1400	1520	1650 H	1790 Aux	1925
060	0.75	400	600 G	830 L	1050	1230	1400	1560	1700	1870	2010 H	2140 Aux	2265
**VS Compressor Speed				1-2	3-4		5-6	7-8		9-10	11-12		

5/10/24

** VS Compressor speed is given for the factory default cfm settings. When the cfm default settings are changed it will change the relationship to the compressor speed that is shown in the table. In cooling mode compressor speeds 10-12 are only available when SuperBoost mode is selected at the thermostat.

* optional 1 HP ECM

Factory settings are at recommended G, L, H and Aux positions

"G" may be located anywhere within the airflow table

"L" setting should be located within the boldface CFM range

"H" setting MUST be located within the shaded CFM range

"Aux" setting MUST be equal to or greater than "H" setting

"Aux" setting MUST be equal to or greater than the minimum allowable CFM for the auxiliary heater kit (see auxiliary heat ratings table)

CFM is controlled within 5% up to the maximum ESP

Max ESP includes allowance for wet coil and standard filter

***Operation for 024 model above Speed 8 is NOT recommended

Setting Blower Speed - Variable Speed ECM

The ABC board's Yellow Config LED will flash the current ECM blower speed selections for G, low, and high continuously with a short pause in between. The speeds can also be confirmed with the AID Tool under the Setup/ECM Setup screen. The Aux will not be flashed but can be viewed in the AID Tool. The ECM blower motor speeds can be field adjusted with or without using an AID Tool.

Variable speed ECM Setup without an AID Tool

The blower speeds for G only, Low (Y1), and High (Y2/Aux) can be adjusted directly at the Aurora ABC board which utilizes the push button (SW1) on the ABC board. This procedure is outlined in the ECM Configuration Mode portion of the Aurora 'Base' Control System section. The Aux cannot be set manually without an AID Tool.

Variable speed ECM Setup with an AID Tool

A much easier method utilizes the AID Tool to change the airflow using the procedure below. First navigate to the Setup screen and then select ECM Setup. This screen displays the current ECM settings. It allows the technician to enter the setup screens to change the ECM settings. Change the highlighted item using the ◀ and ▶ buttons and then press the ◻ button to select the item.

Selecting YES will enter ECM speed setup, while selecting NO will return to the previous screen.

ECM Speed Info	
Blower Only Speed	3
Lo Compressor	6
Hi Compressor	9
Aux Heat	10
Want To Change?	
Yes	No
Option ◀▶	Enter ◻

ECM Speed Setup - These screens allow the technician to select the G, low, high, and auxiliary heat blower speed for the ECM blower motor. Change the highlighted item using the ▲ and ▼ buttons. Press the ◻ button to select the speed.

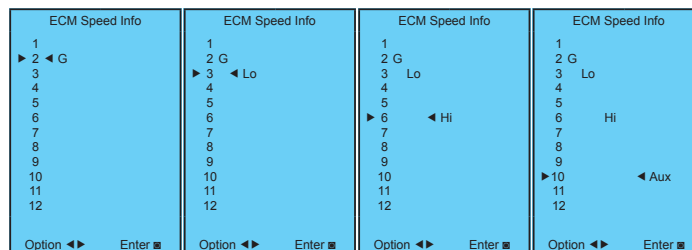

After the auxiliary heat speed setting is selected the AID Tool will automatically transfer back to the ECM Setup screen.

Cooling Airflow Setup - These screens allow the technician to select -15%, -10%, -5%, None or +5% change from the heating airflow. Change the adjustment percentage using the ▲ and ▼ buttons. Press the ◻ button to save the change.

Cooling Airflow Setup	
--- ECM Only ---	
The airflow will be adjusted by the chosen amount in cooling mode.	
Adjustment: -15%	
Want To Change?	
Yes	No
Option ◀▶	Enter ◻

Cooling Airflow Setup	
--- ECM Only ---	
The airflow will be adjusted by the chosen amount in cooling mode.	
Adjustment: -15%	
Change ▼▲	
Enter ◻	

Antifreeze Corrections

Catalog performance can be corrected for antifreeze use. Please use the following table and note the example given.

Antifreeze Type	Antifreeze % by wt	Heating	Cooling	Pressure Drop
EWT - °F [°C]		30 [-1.1]	90 [32.2]	30 [-1.1]
Water	0	1.000	1.000	1.000
	10	0.973	0.991	1.075
Ethylene Glycol	20	0.943	0.979	1.163
	30	0.917	0.965	1.225
	40	0.890	0.955	1.324
	50	0.865	0.943	1.419
	10	0.958	0.981	1.130
Propylene Glycol	20	0.913	0.969	1.270
	30	0.854	0.950	1.433
	40	0.813	0.937	1.614
	50	0.770	0.922	1.816
	10	0.927	0.991	1.242
Ethanol	20	0.887	0.972	1.343
	30	0.856	0.947	1.383
	40	0.815	0.930	1.523
	50	0.779	0.911	1.639
	10	0.957	0.986	1.127
Methanol	20	0.924	0.970	1.197
	30	0.895	0.951	1.235
	40	0.863	0.936	1.323
	50	0.833	0.920	1.399



WARNING: Gray area represents antifreeze concentrations greater than 35% by weight and should be avoided due to the extreme performance penalty they represent.

Antifreeze Correction Example

Antifreeze solution is Propylene Glycol 20% by weight. Determine the corrected heating and cooling performance at 30°F and 90°F respectively as well as pressure drop at 30°F for a 036 operating at 100% capacity.

The corrected cooling capacity at 90°F would be: 35,200 Btu/h x 0.969 = 34,109 Btu/h

The corrected heating capacity at 30°F would be: 37,400 Btu/h x 0.913 = 34,146 Btu/h

The corrected pressure drop at 30°F and 11.5 gpm would be: 7.9 feet of head x 1.270 = 10.03 feet of head

Correction Factor Tables

Air Flow Corrections (Compressor Speeds 1-3)

Airflow		Cooling				Heating		
CFM Per Ton of Clg	% of Nominal	Total Cap	Sens Cap	Power	Heat of Rej	Htg Cap	Power	Heat of Ext
240	60	0.940	0.740	0.967	0.951	0.943	1.106	0.902
275	69	0.950	0.783	0.973	0.959	0.953	1.088	0.918
300	75	0.960	0.827	0.978	0.967	0.962	1.070	0.935
325	81	0.970	0.870	0.984	0.975	0.972	1.053	0.951
350	88	0.980	0.913	0.989	0.984	0.981	1.035	0.967
375	94	0.990	0.957	0.995	0.992	0.991	1.018	0.984
400	100	1.000	1.000	1.000	1.000	1.000	1.000	1.000
425	106	1.030	1.022	1.024	1.026	1.009	0.982	1.016
450	113	1.060	1.045	1.048	1.051	1.019	0.965	1.033
475	119	1.091	1.067	1.071	1.077	1.028	0.947	1.049
500	125	1.121	1.089	1.095	1.103	1.038	0.930	1.065
520	130	1.151	1.111	1.110	1.129	1.047	0.912	1.082

6/29/12

Air Flow Corrections (Compressor Speeds 4-12)

Airflow		Cooling				Heating		
CFM Per Ton of Clg	% of Nominal	Total Cap	Sens Cap	Power	Heat of Rej	Htg Cap	Power	Heat of Ext
240	60	0.928	0.747	0.936	0.929	0.961	1.097	0.938
275	69	0.940	0.789	0.946	0.941	0.967	1.081	0.948
300	75	0.952	0.831	0.957	0.953	0.974	1.064	0.959
325	81	0.964	0.873	0.968	0.965	0.980	1.048	0.969
350	88	0.976	0.916	0.979	0.976	0.987	1.032	0.979
375	94	0.988	0.958	0.989	0.988	0.993	1.016	0.990
400	100	1.000	1.000	1.000	1.000	1.000	1.000	1.000
425	106	1.020	1.023	1.004	1.018	1.010	0.966	1.018
450	113	1.056	1.042	1.008	1.035	1.020	0.932	1.036
475	119	1.072	1.079	1.011	1.053	1.029	0.898	1.054
500	125	1.087	1.095	1.015	1.070	1.039	0.865	1.071
520	130	1.099	1.113	1.019	1.088	1.049	0.831	1.089

6/14/12

Cooling Capacity Corrections

Entering Air WB °F	Total Clg Cap	Sensible Cooling Capacity Multipliers - Entering DB °F										Power Input	Heat of Rejection
		60	65	70	75	80	80.6	85	90	95	100		
55	0.898	0.723	0.866	1.048	1.185	*	*	*	*	*	*	0.985	0.913
60	0.912		0.632	0.880	1.078	1.244	1.260	*	*	*	*	0.994	0.927
63	0.945			0.768	0.960	1.150	1.175	*	*	*	*	0.996	0.954
65	0.976			0.694	0.881	1.079	1.085	1.270	*	*	*	0.997	0.972
66.2	0.983			0.655	0.842	1.040	1.060	1.232	*	*	*	0.999	0.986
67	1.000			0.616	0.806	1.000	1.023	1.193	1.330	1.480	*	1.000	1.000
70	1.053				0.693	0.879	0.900	1.075	1.205	1.404	*	1.003	1.044
75	1.168					0.687	0.715	0.875	1.040	1.261	1.476	1.007	1.141

NOTE: *Sensible capacity equals total capacity at conditions shown.

4/22/12

Heating Capacity Corrections

Ent Air DB °F	Heating Corrections		
	Htg Cap	Power	Heat of Ext
45	1.062	0.739	1.158
50	1.050	0.790	1.130
55	1.037	0.842	1.096
60	1.025	0.893	1.064
65	1.012	0.945	1.030
68	1.005	0.976	1.012
70	1.000	1.000	1.000
75	0.987	1.048	0.970
80	0.975	1.099	0.930

11/10/09

Heat of Extraction/Heat of Rejection

Model		GPM	Heat of Extraction (MBtuh)				GPM	Heat of Rejection (MBtuh)				
			30°F	50°F	70°F	90°F		30°F	50°F	70°F	90°F	110°F
024-036	Full Load	5.5	22.5	32.5	41.7	49.1	4.5	39.1	44.1	42.8	40.3	37.9
		8.0	23.2	33.9	43.3	51.2	7.0	39.4	44.7	43.0	41.1	38.5
		11.5	23.8	34.8	44.7	53.1	9.0	39.8	45.1	43.2	41.4	39.0
048	Full Load	6.5	27.9	38.5	52.5	60.1	5.5	47.9	53.7	51.4	48.5	54.1
		10.0	30.6	42.6	55.9	66.9	8.0	48.2	53.9	51.7	48.9	45.9
		13.5	31.7	44.3	58.9	71.4	10.5	48.7	54.2	51.9	49.2	46.2
060	Full Load	8.5	33.5	48.4	63.9	83.0	6.5	66.9	70.8	69.0	64.1	58.7
		13.0	36.9	51.9	68.4	84.3	10.0	67.3	71.2	69.2	64.3	59.2
		17.0	37.3	53.1	70.5	87.9	13.5	68.0	71.7	69.5	64.7	59.4

Note: operation not recommended in shaded areas.

5/13/24

Water Quality

Material		Copper	90/10 Cupronickel	316 Stainless Steel
pH	Acidity/Alkalinity	7 - 9	7 - 9	7 - 9
Scaling	Calcium and Magnesium Carbonate	(Total Hardness) less than 350 ppm	(Total Hardness) less than 350 ppm	(Total Hardness) less than 350 ppm
Corrosion	Hydrogen Sulfide	Less than 0.5 ppm (rotten egg smell appears at 0.5 ppm)	10 - 50 ppm	Less than 1 ppm
	Sulfates	Less than 125 ppm	Less than 125 ppm	Less than 200 ppm
	Chlorine	Less than 0.5 ppm	Less than 0.5 ppm	Less than 0.5 ppm
	Chlorides	Less than 20 ppm	Less than 125 ppm	Less than 300 ppm
	Carbon Dioxide	Less than 50 ppm	10 - 50 ppm	10 - 50 ppm
	Ammonia	Less than 2 ppm	Less than 2 ppm	Less than 20 ppm
	Ammonia Chloride	Less than 0.5 ppm	Less than 0.5 ppm	Less than 0.5 ppm
	Ammonia Nitrate	Less than 0.5 ppm	Less than 0.5 ppm	Less than 0.5 ppm
	Ammonia Hydroxide	Less than 0.5 ppm	Less than 0.5 ppm	Less than 0.5 ppm
	Ammonia Sulfate	Less than 0.5 ppm	Less than 0.5 ppm	Less than 0.5 ppm
	Total Dissolved Solids (TDS)	Less than 1000 ppm	1000 - 1500 ppm	1000 - 1500 ppm
	LSI Index	+0.5 to -0.5	+0.5 to -0.5	+0.5 to -0.5
Iron Fouling (Biological Growth)	Iron, FE ²⁺ (Ferrous) Bacterial Iron Potential	< 0.2 ppm	< 0.2 ppm	< 0.2 ppm
	Iron Oxide	Less than 1 ppm, above this level deposition will occur	Less than 1 ppm, above this level deposition will occur	Less than 1 ppm, above this level deposition will occur
Erosion	Suspended Solids	Less than 10 ppm and filtered for max. of 600 micron size	Less than 10 ppm and filtered for max. of 600 micron size	Less than 10 ppm and filtered for max. of 600 micron size
	Threshold Velocity (Fresh Water)	< 6 ft/sec	< 6 ft/sec	< 6 ft/sec

NOTES: Grains = ppm divided by 17
mg/L is equivalent to ppm

2/22/12

Water Quality

It is the responsibility of the system designer and installing contractor to ensure that acceptable water quality is present and that all applicable codes have been met in these installations. Failure to adhere to the guidelines in the water quality table could result in loss of warranty. In ground water situations where scaling could be heavy or where biological growth such as iron bacteria will be present, a closed loop system is recommended. The heat exchanger coils in ground water systems may, over a period of time, lose heat exchange capabilities due to a buildup of mineral deposits inside. These can be cleaned, but only by a qualified service mechanic, as special solutions and pumping equipment are required. Hot water generator coils can likewise become scaled and possibly plugged. In areas with extremely hard water, the owner should be informed that the heat exchanger may require occasional flushing.

Heat pumps with cupronickel heat exchangers are recommended for open loop applications due to the increased resistance to build-up and corrosion, along with reduced wear caused by acid cleaning.

Water Treatment

Do not use untreated or improperly treated water. Equipment damage may occur. The use of improperly treated or untreated water in this equipment may result in scaling, erosion, corrosion, algae or slime. Purchase of a pre-mix antifreeze could significantly improve system reliability if the water quality is

controlled and there are additives in the mixture to inhibit corrosion. There are many examples of such fluids on the market today such as Environol™ 1000 (pre-mix ethanol), and others. The services of a qualified water treatment specialist should be engaged to determine what treatment, if any, is required. The product warranty specifically excludes liability for corrosion, erosion or deterioration of equipment.

The heat exchangers and water lines in the units are copper or cupronickel tube. There may be other materials in the buildings piping system that the designer may need to take into consideration when deciding the parameters of the water quality. If antifreeze or water treatment solution is to be used, the designer should confirm it does not have a detrimental effect on the materials in the system.

Contaminated Water

In applications where the water quality cannot be held to prescribed limits, the use of a secondary or intermediate heat exchanger is recommended to separate the unit from the contaminated water. The table above outlines the water quality guidelines for unit heat exchangers. If these conditions are exceeded, a secondary heat exchanger is required. Failure to supply a secondary heat exchanger where needed will result in a warranty exclusion for primary heat exchanger corrosion or failure.

Operating Parameters

024 - Comp Speed 8 - 850 CFM

Entering Water Temp °F	Water Flow	Cooling -- No Hot Water Generation					
		Suction Pressure psig	Discharge Pressure psig	Superheat	Subcooling	Water Temp Rise °F	Air Temp Drop °F DB
30	8.0	109-114	116-126	6-10	8-12	6-10	15-20
50	8.0	128-133	162-172	6-10	6-10	5-8	20-25
70	8.0	130-135	225-232	8-12	6-10	5-8	20-25
90	8.0	134-139	300-310	6-10	6-10	5-8	18-23
110	8.0	136-141	442-452	6-10	8-12	5-9	16-21

6/17/24

024 - Comp Speed 12 - 1350 CFM

Entering Water Temp °F	Water Flow	Heating -- No Hot Water Generation					
		Suction Pressure psig	Discharge Pressure psig	Superheat	Subcooling	Water Temp Drop °F	Air Temp Rise °F DB
30	9.0	66-71	254-264	6-16	6-11	3-7	17-22
50	9.0	91-96	290-300	6-16	6-17	4-9	23-38
70	9.0	134-139	320-330	6-10	6-17	4-9	30-35
90	9.0	174-179	351-361	6-10	6-16	7-11	35-40

6/17/24

036 - Comp Speed 10 - 1300 CFM

Entering Water Temp °F	Water Flow	Cooling -- No Hot Water Generation					
		Suction Pressure psig	Discharge Pressure psig	Superheat	Subcooling	Water Temp Rise °F	Air Temp Drop °F DB
30	9	103-108	129-139	17-25	8-13	6-10	15-20
50	9	124-129	175-185	5-12	5-10	6-10	20-25
70	9	128-134	242-249	5-12	5-10	6-10	20-25
90	9	137-142	298-318	5-10	9-14	6-10	18-23
110	9	139-144	457-467	5-10	9-14	5-9	16-21

6/17/24

036 - Comp Speed 12 - 1500 CFM

Entering Water Temp °F	Water Flow	Heating -- No Hot Water Generation					
		Suction Pressure psig	Discharge Pressure psig	Superheat	Subcooling	Water Temp Drop °F	Air Temp Rise °F DB
30	11.5	66-71	254-264	6-16	6-11	3-7	17-22
50	11.5	91-96	290-300	6-16	6-17	4-9	23-38
70	11.5	134-139	320-330	6-10	6-17	4-9	30-35
90	11.5	174-179	351-361	6-10	6-16	7-11	35-40

6/17/24

048 - Comp Speed 10 - 1400 CFM

Entering Water Temp °F	Water Flow	Cooling -- No Hot Water Generation					
		Suction Pressure psig	Discharge Pressure psig	Superheat	Subcooling	Water Temp Rise °F	Air Temp Drop °F DB
30	10.5	113-118	144-154	17-22	9-14	8-13	19-25
50	10.5	130-135	184-194	10-12	6-11	8-13	19-25
70	10.5	132-137	252-259	10-12	6-11	8-13	18-24
90	10.5	133-138	319-324	10-12	8-12	7-12	17-23
110	10.5	135-140	451-462	10-12	10-12	7-12	17-23

6/17/24

048 - Comp Speed 12 - 1800 CFM

Entering Water Temp °F	Water Flow	Heating -- No Hot Water Generation					
		Suction Pressure psig	Discharge Pressure psig	Superheat	Subcooling	Water Temp Drop °F	Air Temp Rise °F DB
30	13.5	65-70	296-306	10-15	18-23	4-8	20-25
50	13.5	98-103	332-342	7-10	18-23	5-9	28-33
70	13.5	132-137	368-378	7-11	18-23	8-12	34-39
90	13.5	174-179	413-423	7-10	18-23	9-13	36-44

6/17/24

060 - Comp Speed 10 - 1800 CFM

Entering Water Temp °F	Water Flow	Cooling -- No Hot Water Generation					
		Suction Pressure psig	Discharge Pressure psig	Superheat	Subcooling	Water Temp Rise °F	Air Temp Drop °F DB
30	13.5	112-117	156-166	20-24	5-10	8-12	19-25
50	13.5	124-129	190-200	6-10	8-12	8-12	19-25
70	13.5	128-133	255-262	6-10	8-13	8-12	19-25
90	13.5	137-142	333-343	6-10	11-15	8-12	19-25
110	13.5	139-144	343-353	6-10	15-19	8-12	19-25

6/17/24

060 - Comp Speed 12 - 2200 CFM

Entering Water Temp °F	Water Flow	Heating -- No Hot Water Generation					
		Suction Pressure psig	Discharge Pressure psig	Superheat	Subcooling	Water Temp Drop °F	Air Temp Rise °F DB
30	17.0	64-69	270-280	6-10	8-12	4-8	20-26
50	17.0	101-106	305-315	6-10	10-15	4-8	24-30
70	17.0	129-134	339-349	6-10	13-18	6-10	32-38
90	17.0	169-174	377-387	6-10	13-18	8-12	39-45

6/17/24

Pressure Drop

Model	GPM	Pressure Drop (psi)				
		30° F	50° F	70°	90° F	110° F
024-036	11.5	3.60	3.30	3.10	2.90	2.70
	9.0	2.30	2.10	2.00	1.90	1.70
	7.0	1.50	1.40	1.30	1.20	1.10
	6.0	1.20	1.15	1.10	1.05	1.00
	4.5	0.70	0.66	0.64	0.60	0.55
048	13.5	4.60	4.40	4.10	3.80	3.50
	10.5	2.90	2.70	2.50	2.30	2.20
	7.5	1.70	1.60	1.50	1.40	1.30
	6.0	1.20	1.10	1.00	0.96	0.91
	4.0	0.62	0.61	0.60	0.58	0.56
060	17.0	6.40	6.00	5.60	5.20	4.80
	13.5	4.10	3.80	3.60	3.30	3.10
	9.5	2.20	2.10	2.00	1.80	1.70
	7.5	1.70	1.60	1.50	1.40	1.30
	5.0	0.68	0.62	0.58	0.55	0.53

5/10/24

Operation Logic

Heating Mode

When the variable speed controls determine that heating is needed in the space the blower will be turned on, the compressor will be ramped to speed 6 and the loop pump will be started. The compressor will continue to run at speed 6 for 60 seconds for oil circulation. During the 60 second oil circulation the controls will calculate what speed the compressor will need to operate at to maintain the set point in the space. If the compressor is operating at speed 12 and the unit is unable to maintain set point the controls will stage on the electric heat. Electric heat will not operate unless the compressor is already running at speed 12. Every 30 minutes if the compressor has been operating lower than speed 6, the controls will increase the compressor to speed 6 for one minute for oil circulation.

Cooling Mode

When the variable speed controls determine that cooling is needed in the space the blower will be turned on, the reversing valve will be enabled, the compressor will be ramped to speed 6, and the loop pump will be started. The compressor will continue to run at speed 6 for 60 seconds for oil circulation. During the 60 second oil circulation the controls will calculate what speed the compressor will need to operate at to maintain the set point in the space. The compressor will be limited to a maximum of speed 9 for cooling. If additional capacity is needed SuperBoost mode can be enabled from the thermostat allowing the compressor to run at speeds higher than 9 for a period of 24 hours. Every 30 minutes if the compressor has been operating lower than speed 6, the controls will increase the compressor to speed 6 for one minute for oil circulation.

ECM Blower Motor

The variable speed controls will vary the ECM blower output to maintain optimum air flow at each of the 12 compressor speeds. If dehumidification mode is selected during the cooling operation the airflow will be varied to allow for maximum moisture removal.

Variable Speed Loop Pump

The variable speed controls will operate the variable speed loop pump similar to the way the ECM blower motor operates. The speed of the pump will be increased as the compressor speed is increased to maintain adequate water flow.

Safe Mode

The system has encountered an unsafe operating condition that prevents automatic speed control, e.g. lost a sensor signal. To avoid damage to the system, the drive is running the compressor at a fixed speed of 2400 rpm awaiting the problem to be solved and eventually returning to normal operation. If the problem cannot be solved the drive stops and issues an alarm. (See fault/alarm table.)

Derating

The VS compressor utilizes 'envelope control' to maintain performance within operational limits and improve reliability. To accomplish this, pressure sensors for discharge and suction pressure as well as hot gas temperature sensing are used to monitor the conditions in which the compressor operates. The envelope does vary based upon operating speed (rpm). When operating out of these limits the control will attempt to improve the situation by moderating the compressor speed for a larger envelope. When this occurs it can be observed on the Aurora control as an 'E' code. The control will automatically try to resolve the situation. If the situation progresses, a fault and lockout will be generated by the control.

Dehumidification Operation

If there is an active dehumidification demand with no active heating demand, the MHGR valve will open and allow refrigerant flow to the reheat coil. The system compressor percentage will be based on the current SST and the current Target SST. The control will try to maintain the current SST to the Target SST, while operating the compressor capacity between the minimum compressor speed value and the Maximum Reheat Compressor Speed value. When a dehumidification without cooling demand is active, the target blower speed will be set to the Dehumidification Only Speed. In addition, the target LAT that MHGR uses will be the current Neutral LAT Set-point to keep from over-cooling the space. Head Pressure Control (HPC) is also enabled in this mode to maintain SDT based on target.

Cooling with Dehumidification Operation

While operating in the Cooling with Dehumidification, the target LAT that MHGR uses will be the current Cooling LAT Set-point value. The compressor capacity will in general be limited to the Maximum Reheat Compressor Speed value. If the MHGR valve is fully closed, the LAT is more than 1°F above the target SAT value, and the nominal compressor PID value results in a target RPM greater than the current Maximum Reheat Compressor Speed for more than one minute, compressor control will switch from SST to regular cooling mode, and the Maximum Reheat Compressor Speed value will be ignored. Head Pressure Control (HPC) is also enabled in this mode to maintain SDT based on target.

Aurora Control System

Aurora Advanced VS Control

Aurora Advanced VS Control System is a complete residential and commercial comfort system that brings all aspects of the HVAC system into one cohesive module network. The Aurora Advanced VS Control features the Aurora Base Control (ABC) and the Aurora Expansion Board (AXB). The variable speed drive communicates to the Aurora Control and provides variable capacity and envelope control. The ABC features microprocessor control and HP, LP, loss of charge, condensate and freeze detection, over/under voltage faults, along with communicating thermostat capability for complete fault detection text at the thermostat. Aurora uses the Modbus communication protocol to communicate between modules. Each module contains the logic to control all features that are connected to the module. The ABC has two Modbus channels. The first channel is configured for connecting to devices such as a communicating thermostat, expansion board, or other devices. The second channel is configured for connecting the Aurora Interface Diagnostics Tool (AID Tool).

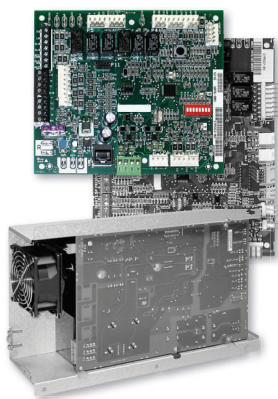

The Aurora AXB expands on the capability of the ABC control board. The additional features include active dehumidification, SuperBoost cooling mode, loop pump linking, intelligent hot water generator control, variable speed pump capability, standard energy, refrigeration, and optional performance monitoring. The AXB also features an optional second field configurable accessory relay, and two home automation inputs that are AID configurable for different types of alarms from sump pumps to home security. The Smart Grid input is AID configurable with many options to react to Utility controlled relay operation for On Peak optimization. The AXB also expands the communication capability for IntelliZone2 ready operation as well as other expansion with the ClimateTalk protocol.

IB-G Interface Board (OptiDry Option Only)



The IB-G is a small electronic circuit board that extends the functionality of an external system controller to drive step motor valves. This interface board is used for the MHGR option to drive the 3-way reheat valve for dehumidification application. In this case, the AXB powers the IB-G board through 24VDC supply and provides an analog 0-10VDC signal to the IB-G for reheat valve modulation. The signal is then converted to a step motor signal to position the valve. The IB-G includes LED indicators for power and valve position, and option for 400 pulses per second (pps), and a valve open or close feature.

Aurora Control Features	Description	Aurora Advanced VS
Advanced Microprocessor Features	Smart Grid, Home Automation Alarm Inputs, and Accessory2 Relay (HRV/ERV)	•
Advanced Hot Water Generator Control	Microprocessor and separate power relay for Hot Water Generator Pump with digital temperature monitoring and multiple HWG setpoint selection.	•
Advanced Speed Pump Control	Microprocessor and separate power relay for loop pump and inline circuit breakers and loop pump linking.	•
Variable Speed Pump	Capable of setup, monitoring and controlling a variable speed flow center.	•
Active Dehumidification	Coil temperature is monitored and air flow is reduced for maximum latent moisture removal.	Variable Speed Only
Modulating Hot Gas Reheat	SST control and LAT monitoring for Dehumidification operation. Controls IB-G interface board for reheat valve modulation during dehumidification. Includes HPC to maintain saturated discharge temperature (SDT) for dehumidification.	•
SuperBoost	Allow the variable speed compressor to ramp up an extra 30% of cooling capacity if needed. This extra 'SuperBoost' will only be available for a 24 hr period and then the unit will revert to normal operation.	•
Smart Grid/Utility Input	Allows simple input to externally enable of occupied/unoccupied mode for basic utility time of use programs.	Dry Contact x1
Home Automation Alarm Input	Allows simple input to signal sump, security, or smoke/CO sensor alarms from other home automation or security systems. The two inputs can be field configured to a number of options and logic.	Dry Contact x2
HAN/Smart Grid Com (AWL and Portal) Kit	Allows direct communication of the Aurora to Smart Meters, Home Automation Network and Internet.	Optional AWL
IntelliZone2 Compatibility	IntelliZone2 communicates to the heat pump via the AXB board.	Optional IntelliZone2

Service Device	Description	Aurora Advanced VS
 Aurora Interface and Diagnostics (AID) Tool	Allows setup, monitoring and troubleshooting of any Aurora Control. NOTE: Although the ABC has basic compatibility with all Aurora, new product features may not be available on older AID Tools. To simplify the basic compatibility ensure the version of AID is at least the same or greater than the ABC software version.	For Service (Ver. 2.20 or greater)

Aurora Control System

Add On Control Feature Kits (field or factory Installed)	Description	Aurora Advanced VS
Geo Energy Monitoring Kit	Monitors real time power consumption of compressor, blower, aux heat and pump. Requires thermostat TPCM32U04A or TPCC32U02.	Standard
Refrigeration Monitoring Kit	Monitors real time pressures, temperatures, superheat, and subcooling.	Standard
Performance Monitoring Kit	Monitors air and water temperatures, and water flow rate and calculates heat of extraction/rejection.	Standard
Data Logging (AWL) Kit	Allows data logging of up to 12 months. Can also be temporarily installed.	Optional
HAN/Smart Grid Com (AWL and Portal) Kit	Allows direct communication of the Aurora to Smart Meters, HAN, and internet.	Optional

Add On Thermostats and Zoning	Description	Aurora Advanced VS
 <p>TPCM32U04A - MonoChrome Communicating Thermostat</p>	Elite Stat with full English fault codes and alerts, communicating thermostat; Required for viewing Energy Monitoring. Monochrome thermostat allows instantaneous energy measurement only. Compatible with AWL.	Optional
 <p>TPCC32U02 - Color Touchscreen Communicating Thermostat</p>	4.3 in. color touchscreen communicating thermostat with full English fault codes and alerts; Required for viewing Energy Monitoring. Color thermostat allows instantaneous and 13 month history. Compatible with AWL.	Optional
 <p>IntelliZone2' Zoning</p>	Includes color main thermostat and up to 6 zones (with variable speed), 4 zones (with dual capacity), and 2 zones (with single speed). There are 4 thermostat options (MasterStat, SensorStat, SensorStat Remote Kit, ZoneStat). Compatible with AWL. IntelliZone2 is not compatible with UPC controls.	Optional

NOTES: The IntelliZone2 or one of the communicating thermostats shown above must be used to control the variable speed heat pump.

Aurora Advanced VS Control Features

NOTE: Refer to the Aurora Advanced VS Control Application and Troubleshooting Guide and the Instruction Guide: Aurora Interface and Diagnostics (AID) Tool for additional information.

Control Features

Software ABC VS Version 4.0 Variable Capacity Compressors

- Random start at power up
- Anti-short cycle protection
- High and low pressure cutouts
- Loss of charge
- Water coil freeze detection
- Air coil freeze detection
- Over/under voltage protection
- Condensate overflow sensor
- Load shed
- Dehumidification (where applicable)
- Emergency shutdown
- Diagnostic LED
- Test mode push button switch
- Two auxiliary electric heat outputs
- Alarm output
- AWL compatible
- Accessory output with N.O. and N.C.
- Modbus communication

Software ABC VS Version 4.0 (OptiDry Only)

- Cooling with dehumidification (OptiDry only)
- Saturated suction temperature (SST) control (OptiDry only)
- Leaving air temperature (LAT) control (OptiDry only)
- Head pressure control (OptiDry only)

Variable Speed ECM Blower Motor

A variable speed ECM blower motor is driven directly using the onboard PWM output. Multiple blower speeds are available based upon requirements of the compressor and electric heat. The blower speeds can be changed either by the variable speed ECM manual configurations mode method or by using the Aurora AID Tool directly.

Advanced Hot Water Generator Control (not available with OptiDry Option)

An AID Tool selectable temperature limit and microprocessor control of the process is featured. This will maximize hot water generation and prevent undesirable energy use. An alert will occur when the hot water input temperature is at or above the set point (130°F default) for 30 continuous seconds. This alert will appear as an E15 on the AID Tool and the hot water pump de-energizes. Hot water pump operations resume on the next compressor cycle or after 15 minutes of continuous compressor operation during the current thermostat demand cycle. Since compressor hot gas temperature is dependent on loop temperature in cooling mode, loop temperatures may be too low to allow proper heating of water. The control will monitor water and refrigerant temperatures to determine if conditions are satisfactory for heating water.

Aurora Control System

VS Drive and Envelope Control

The VS drive operates the compressor between 20 and 100% capacity. The VS drive communicates any out of refrigerant envelope conditions to the Aurora and will attempt to adjust the compressor speed to keep within the envelope. These conditions are measured using the discharge and suction pressure transducers, discharge temperature, and current sensors of the drive.

IntelliZone2 Zoning Compatibility (Optional IntelliZone2 Communicating Zoning)

A dedicated input to connect and communicate with the IntelliZone2 (IZ2) zoning system is provided on P7 on the AXB control board. There is a dedicated communication port using a proprietary ModBus protocol. The AXB is standard on variable speed systems. Consult the IntelliZone2 literature for more information. Not compatible with UPC control opt.

Electronic Expansion Valve (EEV)

The electronic expansion valve is controlled by the AXB board and is set to maintain optimal superheat setting for maximum efficiency. All operation parameters are communicated to the VS drive and the Aurora system.

Modulating Hot Gas Reheat Valve (with OptiDry option only)

The 3-way modulating hot gas reheat valve is controlled by the AXB through a 0-10VDC signal to the IB-G interface board. The valve prevents refrigerant flow through the MHGR circuit during normal system cooling and heating operation. The valve is engaged during dehumidification and modulates refrigerant flow to the reheat coil to help maintain humidity within the space.

AWL - Aurora WebLink (Optional Accessory)

AWL is an add-on WiFi router that connects to the ABC and offers many features:

- Remote access to thermostat settings, schedules, etc. with your smartphone, tablet or laptop.
- Receive Lockout/Fault info via text or email.
- View heat pump energy usage from the internet for the day, week, month, year or real-time.
- Internet AID Tool capability allows remote troubleshooting for the technician.
- Remote AID Tool capability at the heat pump with smartphone, tablet or laptop for the technician.
- Allows data acquisition of the heat pump through the internet, see graphs of performance and chart historical data for the technician.
- Stores historical data on SD card.
- Not compatible with UPC control option

Variable Speed Pump

This input and output are provided to drive and monitor a variable speed pump. The VS pump output is a PWM signal to drive the variable speed pump. The minimum and maximum level are set using the AID Tool. 50% and 100% are the default settings respectively. The VS data input allows a separate PWM signal to return from the pump giving fault and performance information. Fault received from the variable speed pump will be displayed as E16.

Modulating Water Valve

This output is provided to drive a modulating water valve. Through advanced design the 0-10VDC valve can be driven directly from the VS Pump output. The minimum and maximum level are set in the same way as the VS pump using the AID Tool. 50% and 100% are the default settings respectively.

Loop Pump Linking

This input and output are provided so that two units can be linked together with a common flow center. When either unit has a call for loop outputs, both unit's loop pump relays and variable speed pumps are energized. The flow center then can simply be wired to either unit. The output from one unit should be routed to the input of the other. If daisy chained, up to 16 heat pumps can be linked together.

NOTE: Not recommended on OptiDry

Advanced Communication Ports

AXB Communication ports P6 and P8 will provide future expansion via dedicated protocols. These are for future use.

Smart Grid/On Peak (SG) Input

The 'Smart Grid/On Peak' input was designed to allow utilities to utilize simple radio controlled switches to control the On Electric Peak behavior of the Geothermal Heat Pumps and provide demand reduction. With a closed contact signal, this input will limit the operation and thus the power consumption of the unit by disabling the compressor and electric heat as long as the signal is present. Code 7 will flash on the Green LED signifying the 'On Peak' mode. On Peak will also display on communicating thermostats.

Home Automation 1 and 2 Inputs

The Home Automation inputs are simple closed contact inputs that will trigger an AID Tool and thermostat alert for the homeowner. These would require optional sensors and or equipment for connection to the AXB board. With two inputs, two different sensors can be selected. The selected text will then be displayed on the AID Tool and communicating thermostats. These events will NOT alter functionality or operation of the heat pump/accessories and is for homeowner/service notification only.

Home Automation 1 - E23 HA1

With a closed dry contact signal, this input will cause an alarm and Alert Code 23 to indicate on the stat or flash on ABC. The AID Tool will allow configuration of this input between the following selections:

- *No Action*
- *Home Automation Fault* [no lockout info only] - Output from home automation system
- *Security Alarm* [no lockout info only] - Output from home security
- *Sump Alarm Fault* [no lockout info only] - Switch output from sump sensor
- *Smoke/CO Alarm Fault* [no lockout info only] - Switch output from Smoke/CO sensor
- *Dirty Filter Alarm* [no lockout info only] - Output from dirty filter sensor

Aurora Control System

Home Automation 2 – E24 HA2

With a closed dry contact signal, this input will cause an alarm and Alert Code 24 to indicate on the stat or flash on ABC. The AID Tool will allow configuration of this input between the following selections:

- *No Action*
- *Home Automation Fault* [no lockout info only] - Output from home automation system
- *Security Alarm* [no lockout info only] - Output from home security
- *Sump Alarm Fault* [no lockout info only] - Switch output from sump sensor
- *Smoke/CO Alarm Fault* [no lockout info only] - Switch output from Smoke/CO sensor
- *Dirty Filter Alarm* [no lockout info only] - Output from dirty filter sensor

Monitoring Sensor Kits

Energy Monitoring (Standard on all units)

The Energy Monitoring Kit includes two current transducers (blower and electric heat). The variable speed drive measures compressor drive power so that the complete power usage of the heat pump can be measured. The AID Tool provides configuration detail for the type of blower motor and a line voltage calibration procedure to improve the accuracy. This information can be displayed on the AID Tool or selected communicating thermostats. The TPCM32U04A will display instantaneous energy use while the color touchscreen TPCC32U02 will, in addition, display a 13 month history in graph form.

Refrigerant Monitoring

The Refrigerant Monitoring Kit includes two pressure transducers, and three temperature sensors, heating liquid line, suction temperature and existing cooling liquid line (FPI). These sensors allow the measurement of discharge and suction pressures, suction and liquid line temperatures as well as superheat and subcooling. This information will only be displayed on the AID Tool.

Performance Monitoring

The Performance Monitoring Kit includes three temperature sensors, entering and leaving water, leaving air temperature and a water flow rate sensor. With this kit heat of extraction and rejection will be calculated. This requires configuration using the AID Tool for selection of water or antifreeze.

Special Modes and Applications Communicating Digital Thermostats

The Aurora VS controls system also requires either the monochromatic or color touch screen graphic display thermostats for user interface. These displays not only feature easy to use graphical interface but display alerts and faults in plain English.

NOTE: Thermostat humidity reading must be calibrated for OptiDry option for proper humidity control. Sling Psychrometer/Fieldpiece (JL3/FRH3 Psychrometer) recommended for calibration.

‘SuperBoost’ Cooling Mode

Occasionally there can be a requirement for a short term ‘boost’ of cooling capacity during a large party etc. The unit allows the user to select ‘SuperBoost’ mode on the thermostat which will allow the unit VS to ramp up an extra 30% of cooling capacity if needed. This extra ‘SuperBoost’ will only be available for a 24 hr period and then the unit will revert to normal operation. The short term boost does not affect ground loop sizing since it is limited in operation. Continuous use of SuperBoost will result in overheating of the ground loop.

Dehumidification – Active

Active dehumidification (not available with OptiDry) will only activate during cooling operation and is based upon the humidity setpoint of the thermostat being at least 5% below the actual relative humidity and being within the temperature parameters described here. The green status LED will flash code 2 when active. The unit can operate a maximum of 1.5°F below the cooling setpoint. The compressor will ramp up and airflow will begin at a low level. Airflow is then reduced periodically until air coil temperature setpoint is reached. If coil temperature continues to drop, the airflow is increased until air coil setpoint is maintained. After 20 minutes of operation in the Active Dehumidification mode, normal cooling operation will resume for 5 minutes. This cycle continues until the dehumidification setpoint is reached, room temperature is more than 1.5°F below cooling setpoint, or more than 1°F above cooling setpoint (normal cooling takes over). In IntelliZone2 systems, active dehumidification is only enabled when system is operating on compressor speeds 4 or lower. Once active dehumidification is activated the main zone and any other active cooling zone will remain open.

Field Hardware Selectable Options ABC Field Selectable Options via Button (SW1)

Test/Configuration Button (See SW1 Operation Table)

Test Mode

The control is placed in the test mode by holding the push button switch on the ABC SW1 for 2 - 5 seconds. In test mode most of the control timings will be shortened by a factor of sixteen (16). LED3 (green) will flash at 1 second on and 1 second off. Additionally, when entering test mode LED1 (red) will flash the last lockout one time. Test mode will automatically time out after 30 minutes. Test mode can be exited by pressing and holding the SW1 button for 2 to 5 seconds or by cycling the power. **NOTE:** Test mode will automatically be exited after 30 minutes.

Variable Speed ECM Configuration Mode

The control is placed in the variable speed ECM configuration mode by holding the push-button switch SW1 for 5 to 10 seconds, the high, low, and G variable speed ECM speeds can be selected by following the LED display lights. LED2 (yellow) will fast flash when entering the variable speed ECM configuration. When setting G speed LED3

Aurora Control System

(green) will be continuously lit, for low speed LED1 (red) will be continuously lit, and for high speed both LED3 (green) and LED1 (red) will be continuously lit. During the variable speed ECM configuration mode LED2 (yellow) will flash each of the 12 possible blower speeds 3 times. When the desired speed is flashed press SW1, LED2 will fast flash until SW1 is released. G speed has now been selected. Next select low speed, and high speed blower selections following the same process above. After third selection has been made, the control will exit the variable speed ECM configuration mode. Aux blower speed will remain at default or current setting and requires the AID Tool for adjustment.

Reset Configuration Mode

The control is placed in reset configuration mode by holding the push button switch SW1 on the ABC for 50 to 60 seconds. This will reset all configuration settings and the EEPROM back to the factory default settings. LED3 (green) will turn off when entering reset configuration mode. Once LED3 (green) turns off, release SW1 and the control will reset.

ABC DIP Switch (SW2)

- SW2-1** FP1 Selection - Low water coil temperature limit setting for freeze detection. On = 30°F; Off = 15°F.
- SW2-2** FP2 Selection - Low air coil temperature limit setting for freeze detection. On = 30°F; Off = Not Used
- SW2-3** RV - O/B - thermostat type. Heat pump thermostats with "O" output in cooling or "B" output in Heating can be selected. On = O; Off = B.
- SW2-4** Access Relay Operation (P2) and 2-5

Access Relay Operation	SW2-4	SW2-5
Cycle with Blower	ON	ON
Cycle with Compressor	OFF	OFF
Water Valve Slow Opening	ON	OFF
Cycle with Comm. T-stat Hum Cmd	OFF	ON

- SW2-6** CC Operation - selection of single or dual capacity compressor. On = Single Stage; Off = Dual Capacity
NOTE: SW2-6 is not applicable to the unit
- SW2-7** Lockout and Alarm Outputs (P2) - selection of a continuous or pulsed output for both the LO and ALM Outputs. On = Continuous; Off = Pulsed
NOTE: SW2-7 is not applicable to the unit
- SW2-8** *Future Use*

Alarm Jumper Clip Selection

From the factory, ALM is connected to 24 VAC via JW2. By cutting JW2, ALM becomes a dry contact connected to ALG.

Variable Speed ECM Blower Speeds

The blower speeds can be changed either by using the variable speed ECM manual configurations mode method or by using the Aurora AID Tool directly (see Instruction Guide: Aurora Interface and Diagnostics (AID) Tool topic).

AXB DIP Switch (SW1)

DIP 1 - ID: This is the AXB ModBus ID and should always read On.

DIP 2 & 3 - Future Use

DIP 4 & 5 - Accessory Relay2: A second, DIP configurable, accessory relay is provided that can be cycled with the compressor 1 or 2, blower, or the Dehumidifier (DH) input. This is to complement the Accessory 1 Relay on the ABC board.

Position	DIP 4	DIP 5	Description
1	ON	ON	Cycles with blower or ECM (or G)
2	OFF	ON	Cycles with CC1 first stage of compressor or compressor spd 1-12
3	ON	OFF	Cycles with CC2 second stage of compressor or compressor spd 7-12
4	OFF	OFF	Cycles with DH input from ABC board

IB-G Dip Switches/Jumpers (OptiDry Only)

Number of Steps

DIP#	6386
1	OFF
2	OFF
3	OFF

Valve Type Operation

DIP#	OFF
4	Bipolar
5	Std Direction
6	Std Response
7	200pps
8	Std Operation

Input Signal (Jumper Location)

1
0-10V

NOTE: The cells marked with **BOLD** text in the tables above are default settings for the IB-G board required to operate the MHGR valve. The above Jumper/Dip switch settings must not be changed. Modifying default Jumper/Dip switch settings will prevent proper Dehumidification operation.

Field Selectable Options via Software

(Selectable via the Aurora AID Tool)

Many options are field selectable and configurable in Aurora software via the AID Tool. Consult the installation manual or Aurora documentation for further details.

AID Tool Dehumidification Settings (with OptiDry option only)

The Hot Gas Reheat screen on the AID Tool can be found under Settings. It includes the following adjustable settings:

- Mode: Dehum Only/w/Cooling/Off
- SST Reading
- SST Setpoint
- LAT Reading
- LAT Setpoint
- HPC Enable (Go to "OptiDry Setup" under the Setup screen to turn HPC "ON")
- HPC Setpoint (Min SDT while operating)
- Current Valve Pos
- Max RH Comp speed
- Dehum only **Blower** Pump Speed (field selectable based on application)

Aurora Control System

Diagnostics

VS Manual Operation
Sensor Inputs
System Outputs
Timers
VS Service
VS Sensors and Ref
Energy Monitor
Performance Monitor
AXB Inputs
AXB Outputs
OptiDry Status
Back
Option Enter

Setup

AXB Setup
Sensor Kit Setup
Smart Grid Setup
Home Automation Setup
EH Power Mode
OptiDry Setup
Update Model Number
Update Serial Number

OptiDry Status

Mode: DH Only
SST Reading 35.7°F
LAT Reading 68.7°F
HPC Active Yes
Valve Pos. 75%
Pump Speed 50%

Back

OptiDry Setup

SST Setpoint 32.0°F
LAT Setpoint 60.0°F
Ntrl LAT Setpoint 70.0°F
HPC Enable Yes
HPC Setpoint 100.0°F
Min VS Pump Spd 25%
Max RH Comp Spd 9
DH only Blwr Spd 3

Want to Change?
Yes No

Recommended AID Tool Dehumidification Settings

Neutral LAT SP ¹	LAT SP ²	SST SP ¹	Moisture Removal Capacity	Moisture Removal Efficiency	Power Consumption	Recommended Region
70°F <= SP <= 80°F	60°F	32°F <= SP <= 37°F	High	High	Medium	High Humidity
60°F <= SP < 70°F	60°F	32°F <= SP <= 37°F	Med High	Med High	High	Mod. High Humidity
60°F <= SP < 70°F	60°F	37°F < SP <= 45°F	Med Low	Med Low	Medium	Mod. Humidity
70°F <= SP <= 80°F	60°F	37°F < SP <= 45°F	Low	Low	Low	Low Humidity

Use the above table to set LAT and SST parameters for Dehumidification based on recommended regions. The regions are characterized based on the annual mean relative humidity levels (see Relative Humidity Map below). The recommended settings reflect the performance of the unit with OptiDry system with regards to Moisture Removal Capacity, Efficiency and Power Consumption.

NOTE:

1. Default setting for Neutral LAT is 70°F
2. Default setting for LAT is 60°F
3. Default setting for SST is 32°F

Relative Humidity Map

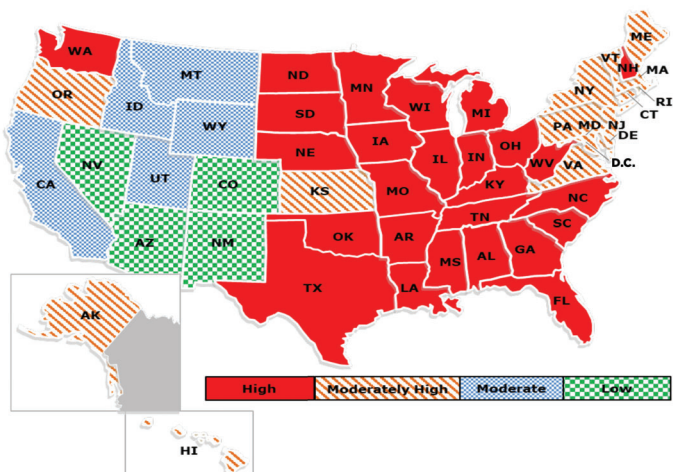

Basic Aurora Safety Features

The following safety features are provided to protect the compressor, heat exchangers, wiring and other components from damage caused by operation outside of design conditions.

Fuse - a 3 amp automotive type plug-in fuse provides protection against short circuit or overload conditions.

Anti-Short Cycle Protection - 4 minute anti-short cycle protection for the compressor.

Random Start - 5 to 80 second random start upon power up.

Fault Retry - in the fault condition, the control will stage off the outputs and then “try again” to satisfy the thermostat VS call. Once the thermostat input calls are satisfied, the control will continue on as if no fault occurred. If 3 consecutive faults occur without satisfying the thermostat VS call, then the control will go to Lockout mode.

Lockout - when locked out, the blower will operate continuously in “G” blower speed setting. The Alarm output (ALM) and Lockout output (L) will be turned on. The fault type identification display LED1 (Red) shall flash the fault code. To reset lockout conditions with SW2-8 On, the demand call must be removed for at least 30 seconds. To reset lockout conditions with SW2-8 Off, the demand call must be removed for at least 30 seconds. Lockout may also be reset by turning power off for at least 30 seconds or by enabling the emergency shutdown input for at least 30 seconds.



CAUTION: Frequent cycling of power to the drive can damage the drive! Wait at least 5 minutes between cycles (connecting and disconnecting power to the drive).

Lockout With Emergency Heat - if the control is locked out in the heating mode, and a call for emergency heat is received, the control will operate in the emergency heat mode while the compressor is locked out. The first emergency heat output will be energized 10 seconds after the W input is received, and the blower will shift to high speed. If the control remains locked out, and the W input is present, additional stage of emergency heat will stage on after 2 minutes. When the W input is removed, all of the emergency heat outputs will turn off, and the variable speed ECM blower will shift to low speed.

High Pressure - fault is recognized when the Normally Closed High Pressure Switch, P4-9/10 opens, no matter how momentarily. The High Pressure Switch is electrically in series with the Compressor Contactor and serves as a hardwired limit switch if an overpressure condition should occur.

Low Pressure - fault is recognized when the Normally Closed Low Pressure Switch, P4-7/8 is continuously open for 30 seconds. Closure of the LPS any time during the 30 second recognition time restarts the 30 second continuous open requirement. A continuously open LPS shall not be recognized during the 2 minute startup bypass time.

Loss of Charge - fault is recognized when the Normally Closed Low Pressure Switch, P4-7/8 is open prior to the compressor starting.

Condensate Overflow - fault is recognized when the impedance between this line and 24 VAC common or chassis ground drops below 100K ohms for 30 seconds continuously.

Aurora Control System

Freeze Detection-Coax - set points shall be either 30°F or 15°F. When the thermistor temperature drops below the selected set point, the control shall begin counting down the 30 seconds delay. If the thermistor value rises above the selected set point, then the count should reset. The resistance value must remain below the selected set point for the entire length of the appropriate delay to be recognized as a fault. This fault will be ignored for the initial 2 minutes of the compressor run time.

Freeze Detection-Air Coil - Air Coil Freeze Detection will use the FP2 input to protect against ice formation on the air coil. The FP2 input will operate exactly like FP1 except that the set point is 30 degrees and is not field adjustable.

Over/Under Voltage Shutdown - An over/under voltage condition exists when the control voltage is outside the range of 18 VAC to 30 VAC. If the over/under voltage shutdown lasts for 15 minutes, the lockout and alarm relay will be energized. Over/under voltage shutdown is self-resetting in that if the voltage comes back within range of 18 VAC to 30 VAC for at least 0.5 seconds, then normal operation is restored.

Other Lockouts and Alarms

Several other lockouts and alarms are shown in the Status LED1 (LED1, Red) table with the associated codes visible on the thermostat, ABC Fault LED, and in text in the AID Tool.

Operation Description

Power Up - The unit will not operate until all the inputs and safety controls are checked for normal conditions. The unit has a 5 to 80 second random start delay at power up. Then the compressor has a 4 minute anti-short cycle delay after the random start delay.

Standby - In standby mode the compressor, pump, and blower motor are not active. The RV may be active. The blower and compressor will be off.

Heating Operation - The unit will operate based upon demand as calculated by the room setpoint algorithm. The resulting compressor speed (1-12) will also select an appropriate blower speed for the selected compressor speed. Aux Heat will not be available (on IntelliZone2 Aux Heat is available on compressor speeds 10-12) until after the 12th compressor speed has been operational and still is not satisfying the thermostat, then auxiliary electric heat will be activated.

Emergency Heat (W) - The blower will be started on G speed, 10 seconds later the first stage of electric heat will be turned on. 5 seconds after the first stage of electric heat is energized the blower will shift to Aux speed. If the emergency heat demand is not satisfied after 2 minutes the second electric heat stage will be energized.

Cooling Operation - The unit will operate based upon demand as calculated by the room setpoint algorithm. The resulting compressor speed, speeds 1-9, (speeds 10-12 are reserved for SuperBoost mode only) will also select an appropriate blower speed. The blower mode will also have the cooling airflow adjustment applied. In all cooling operations, the reversing valve directly tracks the O input. Thus, anytime the O input is present, the reversing valve will be energized.

Dehumidification Operation (OptiDry Option Only)

The refrigerant flows in normal heat pump path in heating and cooling mode. During the Reheat mode, the operation begins with superheated vapor leaving the compressor going through the reheat valve to the reheat air coil. In the reheat coil the high temperature high pressure gas reheats the air exiting the unit to near neutral. Next, the refrigerant exits the reheat coil and passes through a check valve, which is used to prevent refrigerant flow into the reheat coil during normal heating and cooling operation.

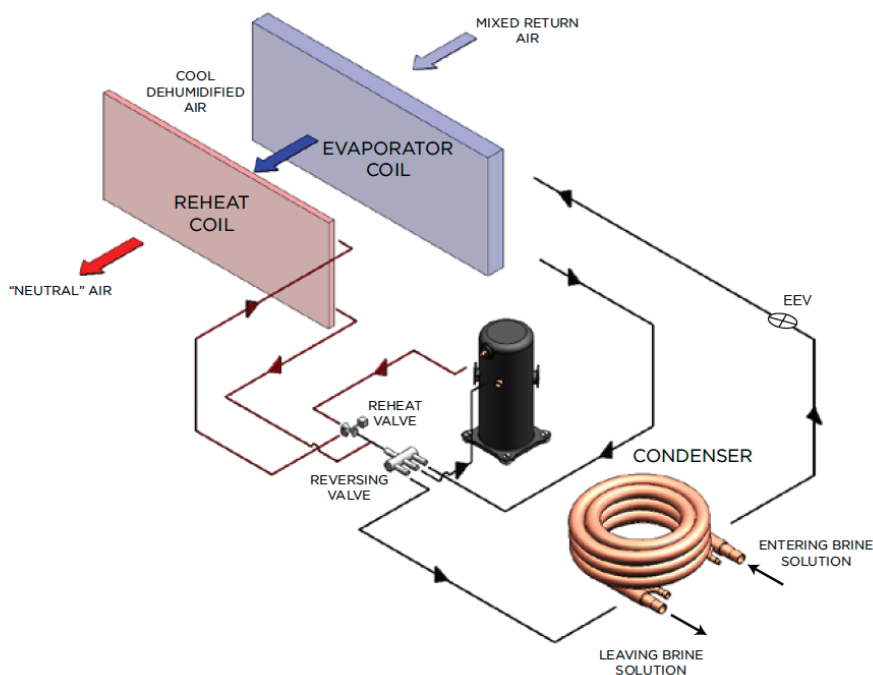

Aurora Control System

The refrigerant passes through the check valve and is then diverted to the coaxial heat exchanger by the four way reversing valve. The hot gas enters the coaxial heat exchanger which will condense the gas to a high pressure liquid due to heat being rejected to the loop fluid. The high pressure liquid leaves the coax and enters the inlet of the EEV. After passing through the EEV the low pressure mixture of liquid/vapor refrigerant expands in the air coil evaporating into a low pressure low temperature gas and moves back through the reversing valve and into the compressor suction. The cycle then starts again by compressing the low pressure low temperature gas into a superheated vapor.

If there is a dehumidification demand with no active heating demand, the system compressor percentage will be based on the current SST and the current Target SST. The control will try to maintain the current SST to the Target SST, while operating the compressor capacity between the minimum compressor speed value and the Maximum Reheat Compressor Speed value. When a dehumidification without cooling demand is active, the target blower speed will be set to the Dehumidification Only Blower Speed. In addition, the target LAT that MHGR uses will be the current Neutral LAT Set-point to keep from over-cooling the space. Head Pressure Control (HPC) is also enabled in this mode to maintain SDT based on target.

Cooling with Dehumidification Operation (OptiDry Option Only)

While operating in the Cooling with Dehumidification, the target LAT that MHGR uses will be the current Cooling LAT Set-point value. The compressor capacity will in general be limited to the Maximum Reheat Compressor Speed value. If the MHGR valve is fully closed, the LAT is more than 1°F above the target SAT value, and the nominal compressor PID value results in a target RPM greater than the current Maximum Reheat Compressor Speed for more than one minute, compressor control will switch from SST to regular cooling mode, and the Maximum Reheat Compressor Speed value will be ignored. Head Pressure Control (HPC) is also enabled in this mode to maintain SDT based on target.

Head Pressure Control (OptiDry Option Only) - This feature is activated during dehumidification to keep saturated discharge temperature elevated to help reheat the air stream through the reheat coil. This allows the system to supply neutral air to the space. When enabled, the system tries to maintain saturated discharge temperature above 100°F by decreasing water flow. Water flow is increased if saturated discharge temperature remains elevated above setpoint while operating in dehumidification mode. The Head Pressure Control also helps the system recover from cold loops during shoulder seasons by controlling water flow, thus keeping discharge pressure elevated to warm up the loop.

- HPC needs to be enabled using the AID Tool. Adjustments to the HPC setpoint should be made if the system struggles to supply neutral air to the space. Refer to AID Tool Dehumidification settings.

- If HPC is enabled, ensure the "Min VS Pump Spd" setting (under OptiDry Setup) on the AID Tool is set to 6% for applications with a VS Pump. For Modulating Water Valve, this setting should not be set below 25%. Failure to follow these guidelines will result in inadequate dehumidification operation. Refer to "Dehumidification Setup" under the Unit Startup section.

Blower (G) - The blower will start immediately upon receiving a thermostat G command. If there are no other commands from the thermostat the variable speed ECM will run on low speed until the G command is removed. Regardless of blower input (G) from the thermostat, the blower will remain on low speed for 30 seconds at the end of each heating, cooling, and emergency heat cycle.

Emergency Shutdown - Four (4) seconds after a valid ES input, P2-7 is present, all control outputs will be turned off and remain off until the emergency shutdown input is no longer present. The first time that the compressor is started after the control exits the emergency shutdown mode, there will be an anti-short cycle delay followed by a random start delay. Input must be tied to common to activate.

Continuous Blower Operation - The blower output will be energized any time the control has a G input present, unless the control has an emergency shutdown input present. The blower output will be turned off when G input is removed.

Load Shed - The LS input disables all outputs with the exception of the blower output. When the LS input has been cleared, the anti-short cycle timer and random start timer will be initiated. Input must be tied to common to activate.



Aurora Interface and Diagnostics (AID) Tool

The Aurora Interface and Diagnostics (AID) Tool is a device that is a member of the Aurora network. The AID Tool is used to troubleshoot equipment which uses the Aurora control via Modbus RTU communication. The AID Tool provides diagnostics, fault management, variable speed ECM setup, and system configuration capabilities to the Aurora family of controls. An AID Tool is recommended, although not required, for variable speed ECM airflow settings. The AID Tool simply plugs into the exterior of the cabinet in the AID Tool port.

Aurora Control System

ABC Control Board Layout

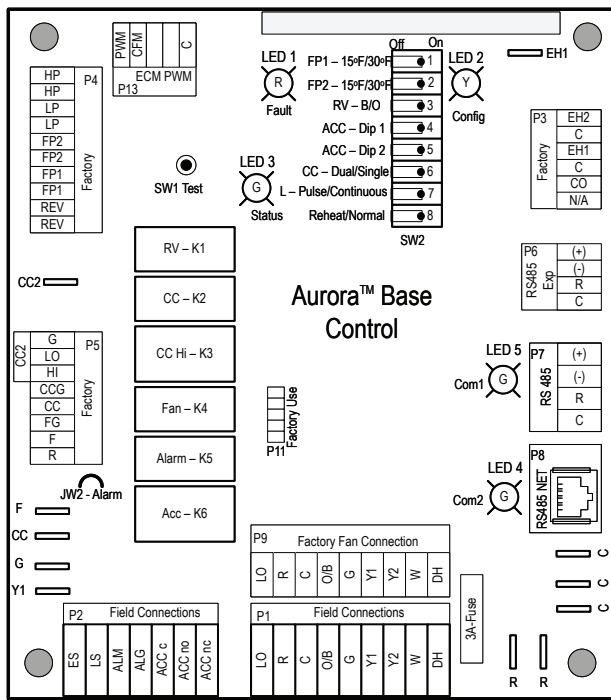

AXB Control Board Layout

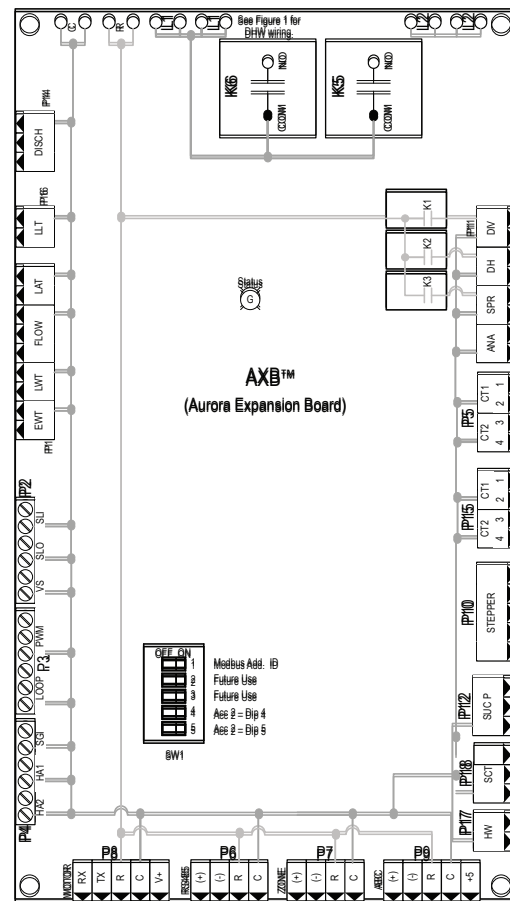

IB-G Interface Board (with OptiDry option only)

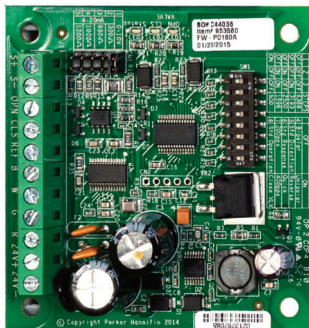

Power Supply/EEV Board (with OptiDry option only)

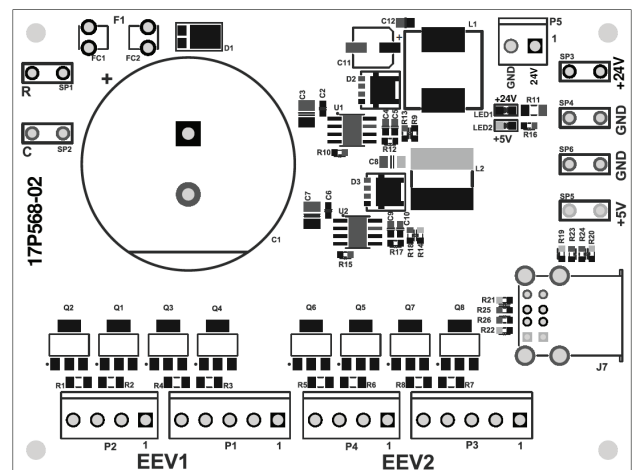

Variable Speed Drive

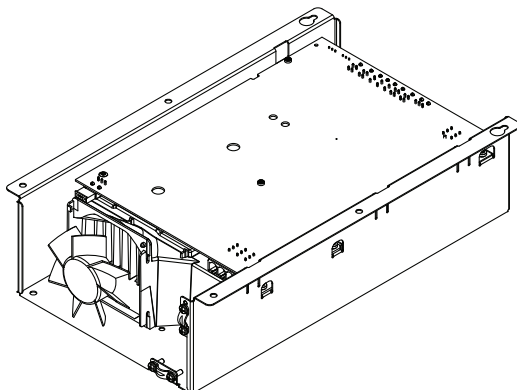

Aurora Control System



Aurora Contractor Connect and Symphony Contractor Connect

The Symphony Contractor Connect (SCC) brings ground source heat pump data and troubleshooting to your fingertips. Symphony Contractor Connect with the use of the Aurora Contractor Connect (ACC) replaces the current AID Tool. This app provides an enhanced and more efficient experience for the service technician in assessing system performance and component troubleshooting. REQUIRES dealer login credentials SCC is for dealer technicians ONLY and includes:

- AID Tool
- Troubleshooting videos and technical literature
- Easy AWL Setup to Home Router
- Perform routine installation chart reading/calculations
- Electronic capture of Start-Up Documentation
- Active Charge Assist/Charge Calculator for split system

Aurora Advanced VS Control LED Displays

These three LEDs display the status, configuration, and fault codes for the control. These can also be read in plain English via the Aurora AID Tool. See the LED tables for further explanation.

Status LED (LED3, Green)

Description of Operation	Fault LED, Green
Normal Mode	ON
Control is Non-functional	OFF
Test Mode	Slow Flash
Lockout Active	Fast Flash
Dehumidification Mode	Flash Code 2
Load Shed	Flash Code 5
Emergency Shutdown	Flash Code 6
On Peak Mode	Flash Code 7
Warning! VS Derated	Flash Code 8
Warning! VS SafeMode	Flash Code 9

Configuration LED (LED2, Yellow)

Description of Operation	Configuration LED, Yellow
No Software Overwritten	ECM Setting
DIP Switch Overwritten	Slow Flash
ECM Configuration Mode	Fast Flash
Reset Configuration Mode	OFF

IB-G LED Display (with OptiDry option only)

The IB-G has three LEDs to visually show the status of the valve and board. The RED LED is a status LED and will be on when that IB-G has power. The YELLOW LED is the Close Valve LED; it will only be on when the valve is fully closed. The GREEN LED is the Valve Open LED and will flash in different sequences depending on valve position. The GREEN LED will flash once for valve positions >0% and including 10%, twice for valve positions >10% and including 20%, etc. The GREEN LED will remain on when the valve is fully open.

Status LED (LED, Red)

Description of Operation	Status
IB-G has power	ON
IB-G has no power	OFF

MHGR Valve LED (LED, Yellow)

Description of Operation	Status
Valve is closed	ON
Valve is open	OFF

MHGR Valve Position LED (LED, Green)

Description of Operation	Status
0%<Valve position<=10%	Flash once
Valve position>10%	Flash twice
Valve position = 100%	ON
Valve position = 0%	OFF

Variable Speed 2.0 LED Status

LED Code	Full Description	Removal
ON	Normal operation of the heat pump	-
OFF	Microprocessor is not operational	Board replacement
Slow Flash	Speeds some timings for faster troubleshooting. Entered from pushed button on ABC	Auto after 20 min
Fast Flash	Lockout is active. Can be removed by hard or soft reset.	Hard or Soft Reset
Code 2	Unit has either Dehumidification Mode Call from dehumidistat (Active or Passive).	Remove Dehumid Call from Stat
Code 5	Active Load Shed (LS) input on ABC	Remove LS input
Code 6	Active Emergency Shutdown (ES) input on ABC	Remove ES input
Code 7	On Peak Mode is signalled from external source thru Smart Grid Input (dig1) or thru ext communication.	Remove Smart Grid Input or com
Code 8	Unit has encountered unacceptable condition and has moderated compressor speed to compensate.	Only automatic removal
Code 9	Unit has encountered unacceptable condition or lost EEV com and has adjusted operation to 2400 rpm and safe EEV %.	Only automatic removal

Aurora Control System

ASB Sensor Board

Refrigerant Leak Detection

The Aurora control system uses the ASB control board to monitor the refrigerant sensor and determine when a fault condition requiring mitigation has been recognized and is active.

The ASB control will provide the indicator for an active refrigerant leak condition requiring mitigation in addition to the currently measured refrigerant level in ppm for each sensor connected to the ASB.

Refrigerant Leak Mitigation

The refrigeration sensor will detect a leak if the LFL (Lower Flammability Limit) exceeds 13%. The ASB board will communicate the leak detection to the ABC control board. The ABC will deactivate the compressor, auxiliary heat and pump outputs. The system's blower will come on, and the system will continue to operate in this state until the ABC is no longer reporting a fault condition.

ASB Control Board

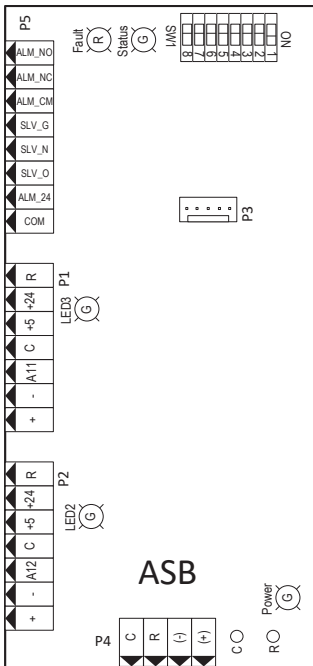

ASB Green Status LED	
OFF	Power Off
Slow Flash	Normal Operation
Fast Flash	ABC Loss Communication
ASB Red Fault LED	
OFF	Power Off
Slow Flash	Alarm
Fast Flash	Sensor Loss Communication

Mitigation Fault Codes

E81 – ASB Leak Detected

This occurs when an ASB has a sensor that has detected A2L refrigerant above its alarm threshold.

E82 – ASB Sensor Problem

This occurs when an ASB has a sensor that has lost communication, has a sensor health problem, or the sensor has an internal error.

E97 – Invalid System Configuration

This occurs when the ABC has not been configured for a refrigeration type, has not been configured for a discharge pressure sensor type, or has not been configured for a suction pressure sensor type. Configuration for a discharge or suction pressure sensor type does not mean the system has that capability, but it must be selected for configuration to be complete.

RDS Refrigeration Detection Sensor

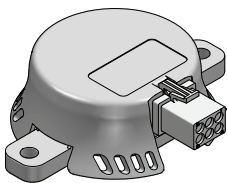

RDS Green Status LED	
Solid	Power Up / Self Test
Blinking	Normal Operation
RDS Red Fault LED	
Solid	Alarm State
Blinking	Sensor Fault

Aurora Control System

Variable Speed 2.0 LED Status

LED Flash Code	Lockout	Reset/Remove	Fault Condition Summary	ABC Action		AID Tool	I22 and Stat Display
				ABC Green Status LED	ABC Red Fault LED		
Off	-						
1	No	Auto	Tstat input error. Autoreset upon condition removal.	Normal	Code 1		
2	Yes	Hard or Soft	HP switch has tripped (>600 psi)	Lockout	Code 2	Lockout - E2 High Press	Lockout - E2 High Press
3	Yes	Hard or Soft	Low Pressure Switch has tripped (<40 psi for 30 continuous sec.)	Lockout	Code 3	Lockout - E3 Low Press	Lockout - E3 Low Press
4	Yes	Hard or Soft	Freeze protection sensor has tripped (<15 or 30 degF for 30 continuous sec.)	Lockout	Code 4	Lockout - E4 Freeze Detection FP2	Lockout - E4 Freeze Detection FP2
5	Yes	Hard or Soft	Freeze protection sensor has tripped (<15 or 30 degF for 30 continuous sec.)	Lockout	Code 5	Lockout - E5 Freeze Detection FP1	Lockout - E5 Freeze Detection FP1
7	Yes	Hard or Soft	Condensate switch has shown continuity for 30 continuous sec.	Lockout	Code 7	Lockout - E7 Condensate	Lockout - E7 Condensate
8	No**	Auto	Instantaneous Voltage is out of range. **Controls shut down until resolved.	Lockout	Code 8	Lockout - E8 Over/Under voltage	Lockout - E8 Over/Under voltage
11	Yes	Hard or Soft	If FPI or 2 Sensor Err	Lockout	Code 11	Lockout - E11 FPI/FP2 Sensor Error	Lockout - E11 FPI/FP2 Sensor Error
13	No	Auto	Any Other Sensor Err	Normal	Code 13	Alert - E13 Non-Critical AXB Sensor Error	Alert - E13 Non-Critical AXB Sensor Error
14	Yes	Hard or Soft	Sensor Err for EEV or HW	Lockout	Code 14	Lockout - E14 Critical AXB Sensor Error	Lockout - E14 Critical AXB Sensor Error
15	No	Auto	HW over limit or logic lockout. HW pump deactivated.	Normal	Code 15	Alert - E15 Hot Water Temp Limit	No Display
16	No	Auto	Alert is read from PWM feedback.	Normal	Code 16	Alert - E16 Var Spd Pump Err	Alert - E16 Var Spd Pump Err
17	No	Auto	I22 Com Fault. Autoreset upon condition removal.	Normal	Code 17	Warning - E17 I22 Comm Error	Warning - E17 I22 Comm Error
18	No	Auto	Any non-critical com error	Normal	Code 18	Alert - E18 Non-Critical Communication Error	Alert - E18 Non-Critical Communication Error
19	No	Auto	Any critical com error. Auto reset upon condition removal	Normal	Code 19	Alert - E19 Critical Communication Error	Alert - E19 Critical Communication Error
21	No	Auto	Loop pressure is below 3 psi for more than 3 minutes	Normal	Code 21	Alert - E51 Low Loop Pressure	No Display
23	No	Auto	Closed contact input is present on Dig 2 input - Text is configurable	Normal	Code 23	Alert - E23 Selected choice	Alert - E23 Selected choice
24	No	Auto	Closed contact input is present on Dig 3 input - Text is configurable	Normal	Code 24	Alert - E24 Selected Choice	Alert - E24 Selected Choice
41	No	Auto	Drive Temp has reached critical High Temp (>239°F/115°C)	Derated	Code 41	Warning! Derated - E41 DriveTemp	Warning! Derated - E41 DriveTemp
42	No	Auto	Discharge temperature has reached critical high temp (> 280°F/138°C)	Derated	Code 42	Warning! Derated - E42 HiDisTemp	Warning! Derated - E42 HiDisTemp
43	No	Auto	Suction Pressure is critically low (< 28 psig)	Derated	Code 43	Warning! Derated - E43 LoSucPres	Warning! Derated - E43 LoSucPres
44	No	Auto	Condensing pressure is critically high (> 119 psig)	Derated	Code 44	Warning! Derated - E44 LoConPress	Warning! Derated - E44 LoConPress
45	No	Auto	Condensing pressure is critically high (> 654 psig)	Derated	Code 45	Warning! Derated - E45 HiConPress	Warning! Derated - E45 HiConPress
46	No	Auto	Supply Voltage is <208V or Max Pwr is reached due to high pressure	Derated	Code 46	Warning! Derated - E46 OutPwrLmt	Warning! Derated - E46 OutPwrLmt
47	No	Auto	Com with EEV is interrupted EEV has gone independent mode	SafeMode	Code 47	Warning! SafeMode - E47 EEVIndCom	Warning! SafeMode - E47 EEVIndCom
48	No	Auto	Com with EEV is interrupted EEV has gone independent mode	SafeMode	Code 48	Warning! SafeMode - E48EEVOutCom	Warning! SafeMode - E48EEVOutCom
49	No	Auto	Ambient Temperature (T _{amb}) is <-76 or > 212 F and out of range or invalid	SafeMode	Code 49	Warning! SafeMode - E49	Warning! SafeMode - E49
51	Yes	Hard or Soft	Discharge Sensor (Sd) is > 280 F or invalid (-76 to 392 F)	Lockout	Code 51	Lockout! - E51 DisTempSnr	Lockout! - E51 DisTempSnr
52	Yes	Hard or Soft	Suction Pressure (P _s) is invalid (0 to 232 psi)	Lockout	Code 52	Lockout! - E52 SucPrsSnr	Lockout! - E52 SucPrsSnr
53	10x then Yes	Hard or Soft	Low condensing pressure (P _c) or invalid (0 to 870 psi) Retry 10x.	Norm then Lockout	Code 53	Lockout! - E53 ConPrsSnr	Lockout! - E53 ConPrsSnr
54	Yes	Hard or Soft	Supply Voltage is <180V (190V to reset) or powered off/on too quickly (<30 sec.)	Lockout	Code 54	Lockout! - E54 LowSupVolt	Lockout! - E54 LowSupVolt
55	10x then Yes	Hard or Soft	Comp Operating out of envelope (P _d) more than 90 sec. Retry 10x.	Norm then Lockout	Code 55	Lockout! - E55 OutEnvelop	No Display
56	Yes	Hard or Soft	Over current tripped by phase loss, earth fault, short circuit or major drive fault.	Lockout	Code 56	Lockout! - E56 OverCurrnt	Lockout! - E56 OverCurrnt
57	Yes	Hard or Soft	DC Link Voltage to compressor is >450Vdc or at minimum voltage (<185Vdc).	Lockout	Code 57	Lockout! - E57 Over/Under Volt	Lockout! - E57 Over/Under Volt
58	Yes	Hard or Soft	Drive Temp has reached critical High Temp >239 F	Lockout	Code 58	Lockout! - E58HiDrivTemp	Lockout! - E58HiDrivTemp
59	Yes	Hard or Soft	The MOC has encountered an internal fault or an internal error. Probably fatal.	Lockout	Code 59	Lockout! - E59 DrvIntErr	Lockout! - E59 DrvIntErr
61	Yes	Hard or Soft	More than one SafeMode condition is present: requiring lockout.	Lockout	Code 61	Lockout! - E61 MultSafeMd	Lockout! - E61 MultSafeMd
71	Yes	Hard or Soft	High superheat and high EEV opening % for a long time will trigger a loss of charge fault	Lockout	Code 71	Lockout! - E71 LossCharge	Lockout! - E71 LossCharge
72	No	Auto	Suction Temperature Sensor is invalid (-76 to 392 F)	SafeMode	Code 72	Warning! SafeMode - E72 SucTempSnr	Warning! SafeMode - E72 SucTempSnr
73	No	Auto	Leaving Air Temperature Sensor is invalid (-76 to 392 F)	Normal	Code 73	Alert - E73 LAT Sensor	No Display
74	No	Auto	Suction pressure has exceeded that maximum operating level for 90 sec.	SafeMode	Code 74	Warning! SafeMode - E74 MaxOpPress	Warning! SafeMode - E74 MaxOpPress

Refrigerant Circuit Guideline

Symptom	Head Pressure	Suction Pressure	Compressor Amp Draw	Superheat	Subcooling	Air Temp. Differential	Water Temp. Differential
Under Charged System (Possible Leak)	Low	Low	Low	High	Low	Low	Low
Over Charged System	High	High	High	Normal	High	Normal/Low	Normal
Low Air Flow Heating	High	High	High	High/Normal	Low	High	Low
Low Air Flow Cooling	Low	Low	Low	Low/Normal	High	High	Low
Low Water Flow Heating	Low/Normal	Low/Normal	Low	Low	High	Low	High
Low Water Flow Cooling	High	High	High	High	Low	Low	High
High Air Flow Heating	Low	Low	Low	Low	High	Low	Low
High Air Flow Cooling	Low	High	Normal	High	Low	Low	Normal
High Water Flow Heating	Normal	Low	Normal	High	Normal	Normal	Low
High Water Flow Cooling	Low	Low	Low	Low	High	Normal	Low
Low Indoor Air Temperature Heating	Low	Low	Low	Normal	High	Normal	Normal/High
Low Indoor Air Temperature Cooling	Low	Low	Low	Normal/Low	High	Low	Low
High Indoor Air Temperature Heating	High	High	High	Normal/High	Normal/Low	Low	Normal
High Indoor Air Temperature Cooling	High	High	High	High	Low	Low	High
Restricted EEV (Check Service Advisory)	High	Low	Normal/Low	High	High	Low	Low
Insufficient Compressor (Possible Bad Valves)	Low	High	Low	High	Normal/High	Low	Low
Scaled Coaxial Heat Exchanger Heating	Low	Low	Low	Normal/Low	High	Low	Low
Scaled Coaxial Heat Exchanger Cooling	High	High	High	Normal/Low	Low	Low	Low
Restricted Filter Drier	Check temperature difference (delta T) across filter drier.						

6/1/12

Electrical Information

General

Be sure the available power is the same voltage and phase as that shown on the unit serial plate. Line and low voltage wiring must be done in accordance with local codes or the National Electric Code, whichever is applicable. The compressor has no internal overload. The circuit breaker in the control box is the overload protection for the drive and the compressor. Bypassing the circuit breaker could result in damage to the compressor and voiding the warranty.

Unit Power Connection

Connect the incoming line voltage wires to L1 and L2 of the contactor as shown in Figure 13c for single-phase unit. Consult the Unit Electrical Data in this manual for correct fuse sizes.

Open lower front access panel. Remove ground fastener from bottom of control box (Figure 13b). Swing open control box (Figure 13a). Insert power wires through knockouts on lower left side of cabinet. Route wires through left side of control box and connect to contactor and ground (Figure 13c). Close control box and replace grounding fastener before unit startup.



CAUTION: Frequent cycling of power to the drive can damage the drive! Wait at least 5 minutes between cycles (connecting and disconnecting power to the drive).

Accessory Relay

A set of “dry” contacts has been provided to control accessory devices, such as water solenoid valves on open loop installations, electronic air cleaners, humidifiers, etc. This relay contact should be used only with 24 volt signals and not line voltage power. The relay has both normally open and normally closed contacts and can operate with either the blower or the compressor. Use DIP switch SW2-4 and 5 to cycle the relay with blower, compressor, or control a slow opening water valve. The relay contacts are available on terminals #1 and #3 for normally closed, and on terminals #2 and #3 for normally open on P2.

A second configurable accessory relay is provided on the AXB board. When powering high VA draw components such as electronic air cleaners or VM type open loop water valves, R should be taken ‘pre-fuse’ from the ‘R’ quick connect on the ABC board and not the ‘post-fuse’ ‘R’ terminal on the thermostat connection. If not, blown ABC fuses might result.

208 Volt Operation

All 208/230 units are factory wired for 230 volt operation. For 208 volt operation, the red and blue transformer wires must be switched on terminal strip PS.

Figure 13a:
Wire access (control box open)

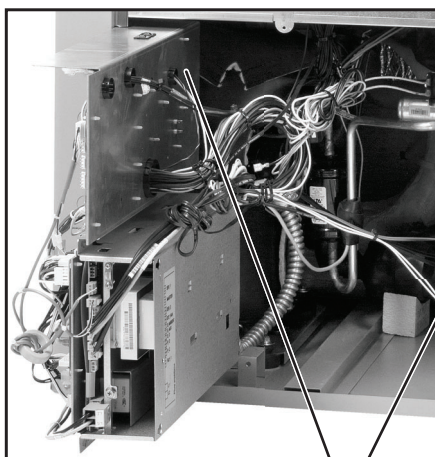

Wire Insert Location

Figure 13b:
Wire access (control box closed)

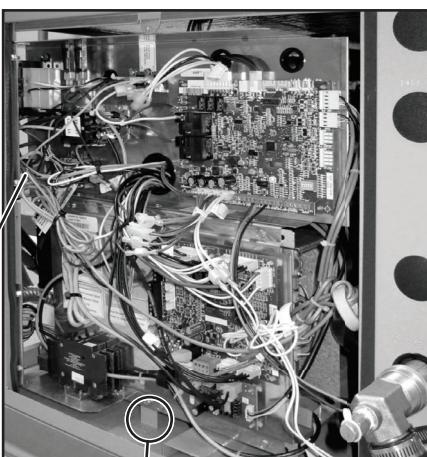

Ground Fastener must be installed for proper unit ground

Figure 13c:
Line Voltage 208-230/60/1 control box

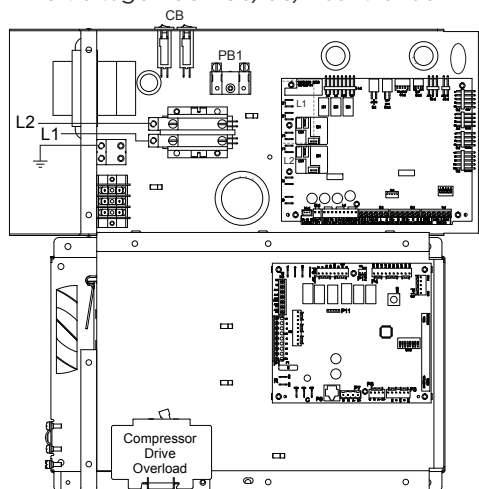

Electronic Thermostat Installation

Position the thermostat subbase against the wall so that it is level and the thermostat wires protrude through the middle of the subbase. Mark the position of the subbase mounting holes and drill holes with a 3/16-inch bit. Install supplied anchors and secure base to the wall. Thermostat wire must be 4 or 5 conductor for communicating thermostats, 20-AWG (minimum) wire. Shielded communication cable is recommended. Strip the wires back 1/4-inch (longer strip lengths may cause shorts) and insert the thermostat wires into the P7 connector as shown. Tighten the screws to ensure secure connections. The thermostat may have either screw or spring clip connectors, requiring the same wiring. **See instructions enclosed in the thermostat for detailed installation and operation information.**

Figure 15: Thermostat Wiring (Communicating Style Signals)

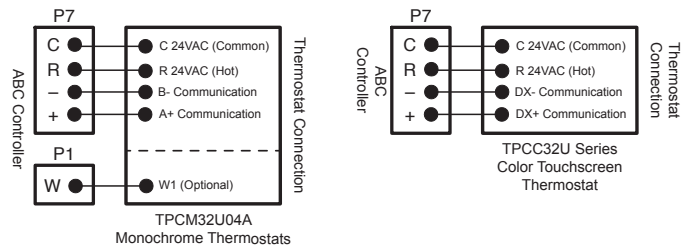

NOTE: If using the IntelliZone2 zoning system, then disregard the diagrams above. The IntelliZone2 system will connect directly to the AXB control board instead. See the IntelliZone2 installation manual for more details.

Electrical Information

Fixed Speed Flow Center

The pump(s) will be connected to the terminals on PB1 in the unit electrical box as shown in Figure 3a. The pumps will automatically be cycled as required by the unit or by a signal from another unit sharing the flow center (See Figures 5 and 6). Pumps are protected by circuit breakers (CB) shown in Figure 3a.

Figure 3a: Variable Speed Unit Wiring for Loop Pumps

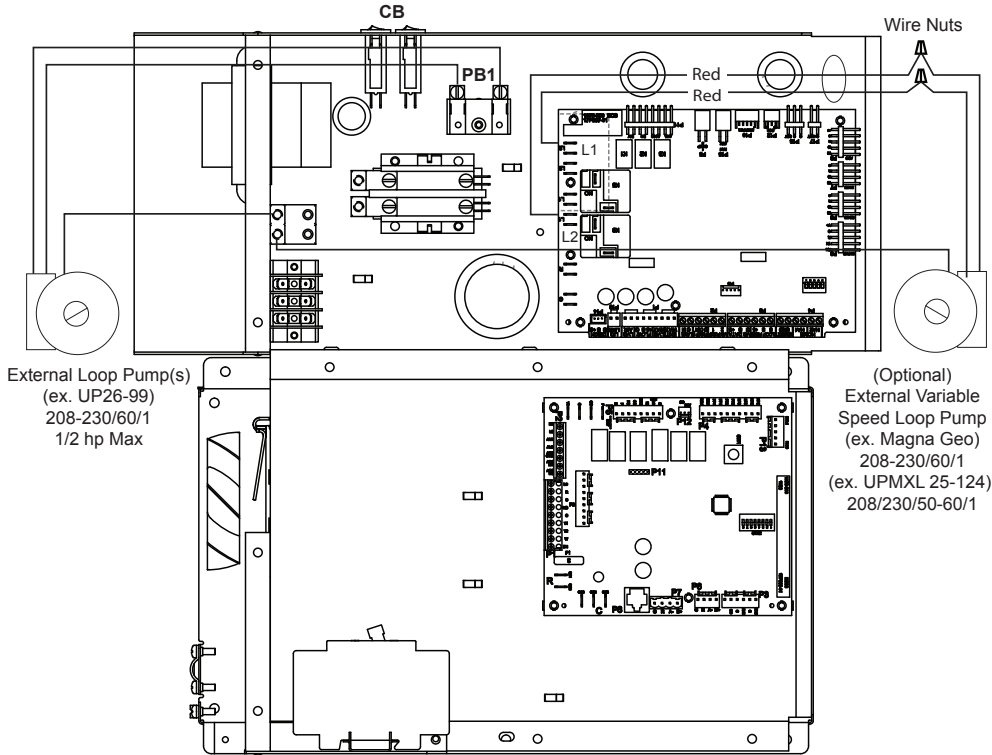

NOTES: For closed loop systems with antifreeze protection, set SW2 DIP Switch #1 to the "Loop" position on units with the Aurora control and SW2-2 should be set to "Loop" on the Premier control.

Figure 3c: FLXL2D-W and FCL Flow Center Wiring (Not Referenced)

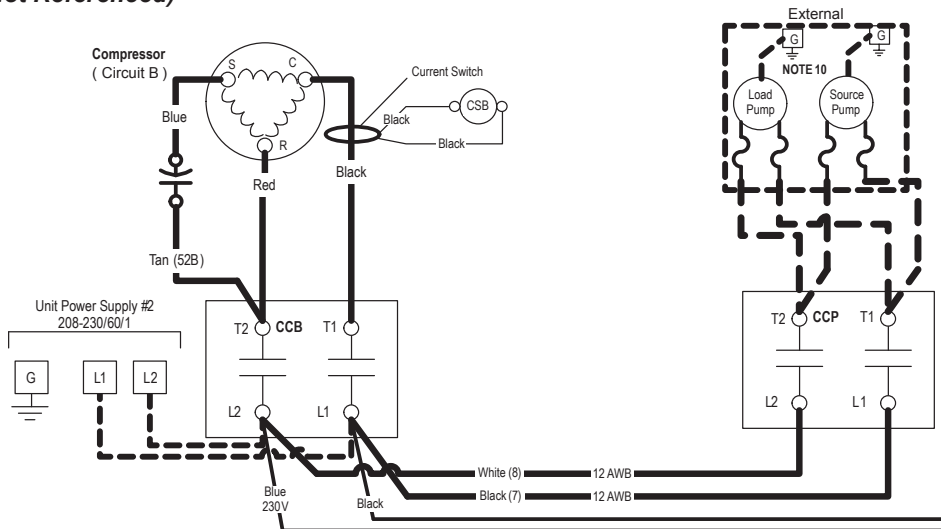

NOTES: FLXL2D-W and FCL Flow Centers must be wired to a separate contactor (20 amp minimum). The HydroZone Accessory Control Box works best for this application.

Electrical Information - Flow Centers

Variable Speed Flow Center cont.

Two Pump Variable Speed Flow Center

If a variable speed two pump flow center is used, the flow center will come with four red and two green wires for the high voltage wiring. The second set of (2) red and (1) green wires is provided for installation flexibility. The variable speed pump **MUST** be powered at all times and therefore **MUST** be wired to the “L” side of electrical system or damage to the pump will occur (pump cannot be powered from “T” side of compressor contactor). The UPMXL 25-124 pump has screw terminals for the high voltage connection. Connect the red HIGH VOLTAGE wires to L1 and L2 on the AXB, connect the green GROUND wire to the ground lug, as shown in figure 4d. Follow all electrical and local codes for wiring.

The variable speed UPMXL 25-124 pump also requires a low voltage signal to operate properly, if the low voltage signal isn't present the pump will run at 100%. Route the low voltage harness connected to the right hand pump to the AXB screw terminals on P2 and P3 connectors. Route the low voltage harness connected to the left hand pump to the AXB screw terminals on P2 and P3 connector per figure 4c. The black wire on the left hand pump will have a label on it that reads **“DO NOT CONNECT THIS WIRE. ONLY ONE VS PUMP FEEDBACK SIGNAL CAN BE CONNECTED TO AXB BOARD”**.

Both the low and high voltage harnesses are labeled. The pump will be automatically cycled as required either by the unit or by a signal from another unit sharing the same flow center. Pumps are protected by circuit breakers as shown on the unit schematic.

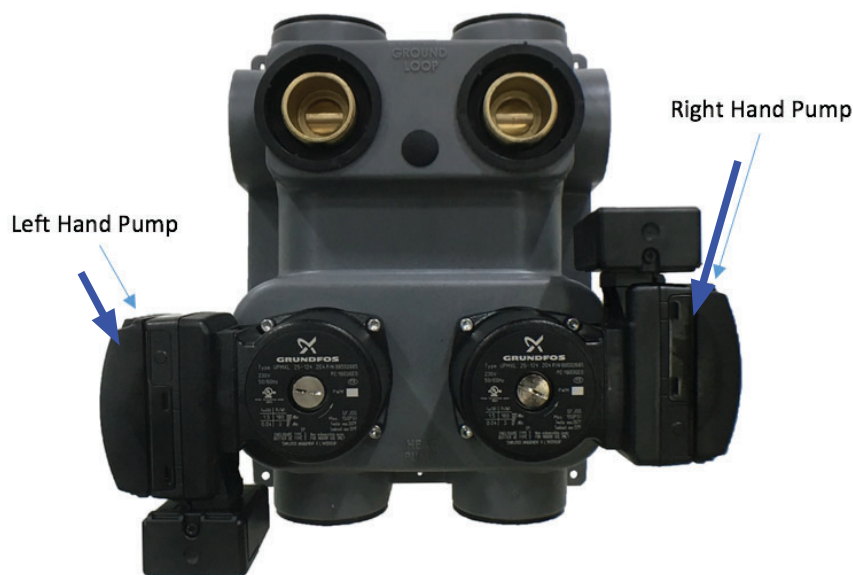

NOTE: Both pumps will speed up and slow down together.

Electrical Information - Flow Centers (cont.)

Two Pump Variable Speed Flow Center cont.

The use of the black wire on the left hand pump (Bottom on NP/NPD with 2 VS pumps in same circuit) is ONLY to be connected for troubleshooting of the pumps. The left hand pump (Bottom on NP/NPD with 2 VS pumps in same circuit) will have a closed end splice connector crimped to the black wire. Cut the closed end splice connector off and strip the wire. During troubleshooting remove the black wire from the right hand pump (Top on NP/NPD with 2 VS pumps in same circuit) from the AXB P3 VS DATA S screw terminal and connect the black wire from the left hand pump (Bottom on NP/NPD with 2 VS pumps in same circuit) to the same location. After the troubleshooting is complete remove the black wire from the left hand pump and connect the black wire from the right hand pump.

Place electrical tape or wire nut on the left hand pump (Bottom on NP/NPD with 2 VS pumps in same circuit) black wire. The two pump variable speed flow center cannot have each UPMXL 25-124 pump wired to two separate heat pumps otherwise damage to the pumps will occur (unless it's an NPD Series flow center).

Figure 4c: Two VS Pump Low Voltage Wiring

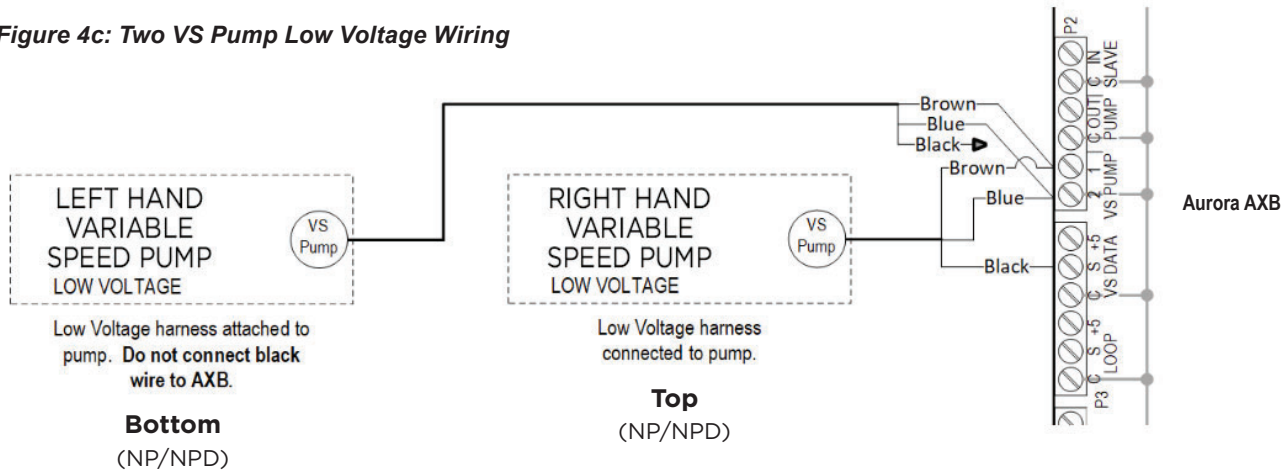

Note: Aurora AXB must be used to control the UPMXL 25-124 pump.

Figure 4d: Two VS Pump High Voltage Wiring

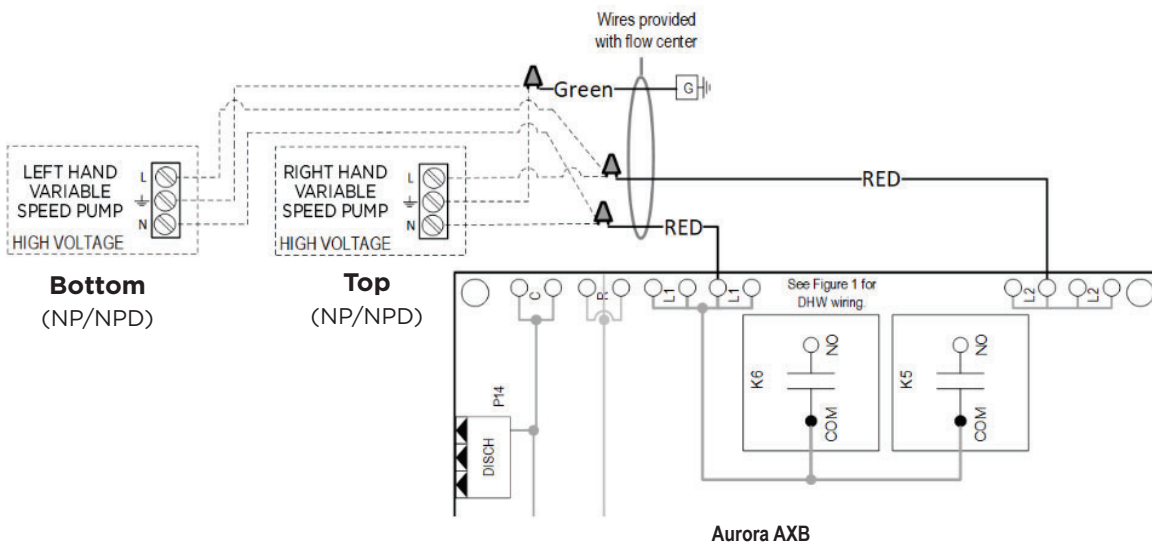

Closed Loop Ground Source Systems

NOTE: For closed loop systems with antifreeze protection, set SW2-1 to the “LOOP” (15°F) position. (Refer to the DIP Switch Settings table in the Aurora Control section.)

Once piping is completed between the unit, pumps and the ground loop, final purging and charging of the loop is required. A flush cart (or a 1.5 HP pump minimum) is needed to achieve adequate flow velocity in the loop to purge air and dirt particles from the loop itself. A filter **MUST** be used when flushing a loop. The standard 100 micron filter bag (LFC-F100M) is acceptable for capturing relatively large debris such as pipe shavings, gravel, and medium sand particles. In certain installation locations other smaller materials such as fine sand, silt, and clay can be less than 75 microns. For these smaller particles the use of the 1 micron filter bag is required (LFC-F1M). It is also recommended to run the flush cart with the 1 micron filter bag for at least 30 minutes. Antifreeze solution is used in most areas to prevent freezing. Flush the system adequately to remove as much air as possible then pressurize the loop to a static pressure of 40-50 psi (summer) or 50-75 psi (winter). This is normally adequate for good system operation. Loop static pressure will fluctuate with the seasons. Pressures will be higher in the winter months than during the cooling season. This fluctuation is normal and should be considered when initially charging the system.

After pressurization, be sure to turn the venting (burping) screw in the center of the pump two (2) turns open (water will drip out), wait until all air is purged from the pump, then tighten the plug. Ensure that the loop pumps provide adequate flow through the unit(s) by checking the pressure drop across the heat exchanger and comparing it to the unit capacity data in this catalog. 2.5 to 3 gpm of flow per ton of cooling capacity is recommended in earth loop applications.

Figure 7: Closed Loop Ground Source Application

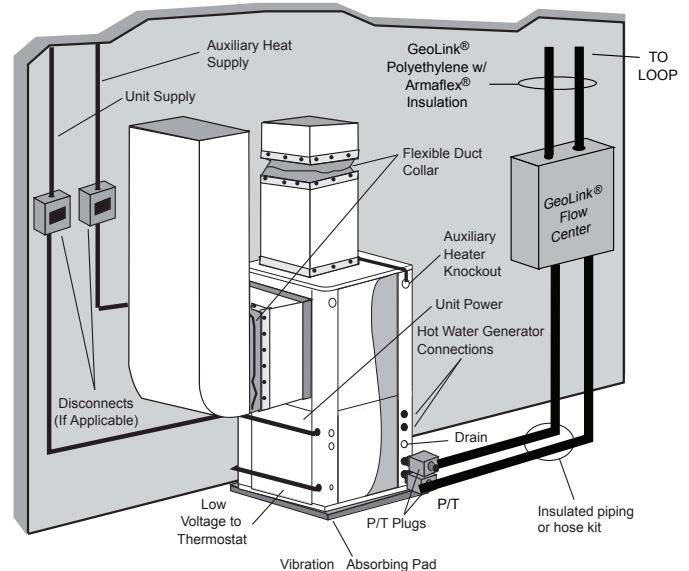

NOTE: Additional information can be found in Flow Center installation manual and Flush Cart manual.

Closed Loop Ground Source Systems cont.

Multiple Units on One Flow Center

When two units are connected to one loop pumping system, pump control is automatically achieved by connecting the SL terminals on connector P2 in both units with 2-wire thermostat wire. These terminals are polarity dependant (see Figure 8). The loop pump(s) may be powered from either unit, whichever is more convenient. If either unit calls, the loop pump(s) will automatically start. The use of two units on one flow center is generally limited to a total of 20 gpm capacity. It is recommended that water solenoid valves be installed on heat pumps that share a flow center. This is to allow water flow through only the heat pump that has a demand. Circulating fluid through a heat exchanger of a system that is not operating could be detrimental to the long term reliability of the compressor.

Variable Speed Pump Setup

When using a variable speed pump flow center (FCV type) the use of an AID Tool will be necessary to adjust minimum and maximum flow rates. The factory default is: minimum=50% and maximum=100% speed levels. See the unit Variable Speed Pump Setup and Modulating Water Valve Setup instructions within the Unit Startup section which is located in the back of this manual. Always ensure that there is adequate flow for the heat pump. See Recommended Minimum/Maximum Flow Rates table.

NOTE: When sharing a flow center, the variable speed heat pump should be the primary unit. When two variable speed heat pumps share a flow center, the larger capacity heat pump should be the primary unit.

Recommended Minimum/Maximum Flow Rates

Size	Closed Loop (minimum)	Closed Loop (maximum)	Open Loop (minimum)	Open Loop (maximum)
	Flow Rate GPM	Flow Rate GPM	Flow Rate GPM	Flow Rate GPM
024-036	5.0	12.0	5.0	8.0
48	5.0	15.0	5.0	10.0
60	5.0	18.0	5.0	12.0

5/13/24

Figure 8: Primary/Secondary Hook-up

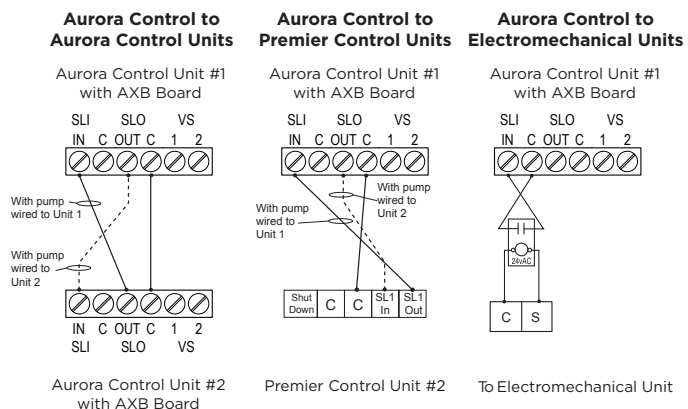

Flow Center Requirement for OptiDry

Variable Speed Flow Center or Modulating Water Valve is required for OptiDry option. This is critical for Head Pressure Control which controls saturated discharge temperature by modulating water flow to maintain adequate loop temperatures for dehumidification. **Failure to follow this requirement will result in inadequate dehumidification operation and the system will not be able to supply neutral air to the space.**

Open Loop Ground Water Systems

Typical open loop piping is shown below. Always maintain water pressure in the heat exchanger by placing water control valves at the outlet of the unit to prevent mineral precipitation. Use a closed, bladder-type expansion tank to minimize mineral formation due to air exposure. Ensure proper water flow through the unit by checking pressure drop across the heat exchanger and comparing it to the figures in unit capacity data tables in the specification catalog. 1.5-2 gpm of flow per ton of cooling capacity is recommended in open loop applications.

Discharge water from the unit is not contaminated in any manner and can be disposed of in various ways, depending on local codes, i.e. recharge well, storm sewer, drain field, adjacent stream or pond, etc. Most local codes forbid the use of sanitary sewer for disposal. Consult your local building and zoning departments to assure compliance in your area. On VS systems, a modulating valve, as shown in figure 9a is the best choice to limit water consumption. The WWKVS well water kit with modulating valve is the recommended setup for open loop applications with variable speed products.

NOTE: For open loop/groundwater systems or systems that do not contain an antifreeze solution, set SW2-Switch #1 to the "WELL" (30°F) position. (Refer to the DIP Switch Settings in the Aurora Control section.) Slow opening/closing solenoid valves (type V) or modulating valves are recommended to eliminate water hammer.

Modulating Water Valve Setup

When using a modulating water valve kit (4MWVK or 5MWVK) the use of an AID Tool will be necessary to adjust minimum and maximum flow rates. The factory default is: minimum=50% and maximum=100% flow levels. It is recommended to start with a minimum setting of 65% and adjust from there if necessary. See the Variable Speed Pump Setup and Modulating Water Valve Setup instructions within the Unit Startup section which is located in the back of this manual. See Recommended Minimum and Maximum Flow Rates table. Always ensure that there is adequate flow for the heat pump. A modulating water valve is preferred on variable speed system to conserve water.

Figure 10: Open System - Groundwater Application

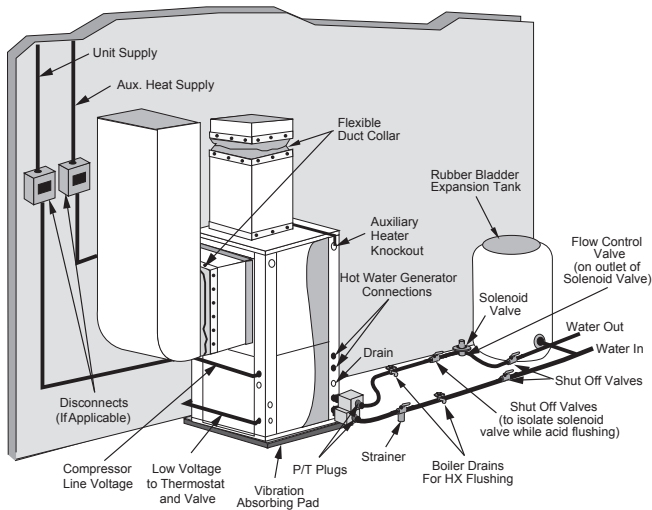

Figure 9a: Modulating Water Valve Connection Option

Typical 0-10VDC modulating water valve.

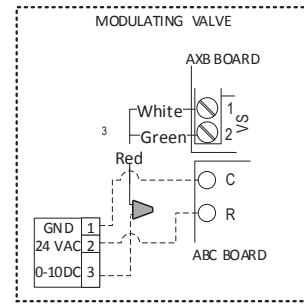

Figure 9b: Open Loop Solenoid Valve Connection Option

Typical slow operating external 24V water solenoid valve (type V) wiring.

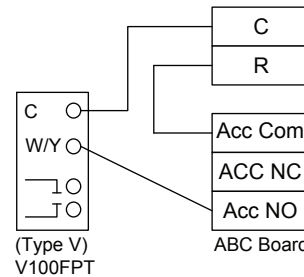
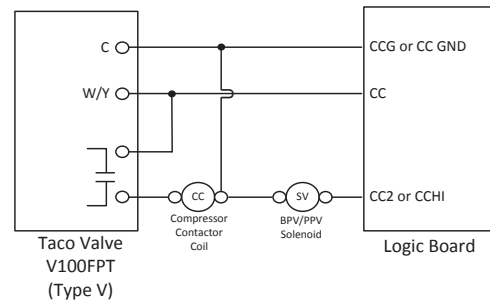

Figure 9c: Wiring diagram for dual water valve installations, one type V slow operating solenoid and one BPV100/PPV100 quick operating solenoid.



Note: SW2-4 should be 'ON' and SW2-5 should be 'OFF'.

Figure 9d: Open Loop Solenoid Valve Connection Option

Typical quick operating external 24V water solenoid valve (type PPV100 or BPV100) wiring.

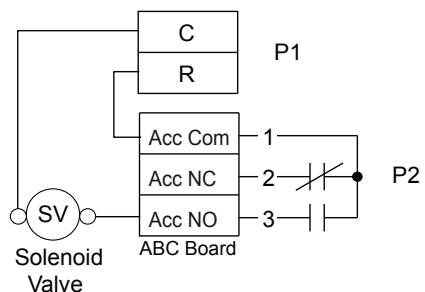

NOTE: SW2-4 and SW2-5 should be "OFF" to cycle with the compressor.

Compressor & Thermistor Resistance

Model	Compressor Model No.	Winding Resistance at 70 °F
		208-230/60/1
024-036	VZH028CWDMB	0.185 ± 7%
048	VZH035CWDMB	0.185 ± 7%
060	VZH044CWDMB	0.185 ± 7%

5/13/24

VRJ scroll compressors are equipped with an IPM (permanent magnet motor). Winding resistance is the resistance between indicated terminal pins at 77°F (Resistance value ± 7%). Winding resistance is generally low and it requires adapted tools for precise measurement. Use a digital ohm-meter capable of connecting a 4 wire probe. Use the 4 Wire Kelvin method and measure resistances under stabilized ambient temperature. Winding resistance varies strongly with winding temperature; If the compressor is stabilized at a different value than 77°F, the measured resistance must be corrected with the following formula:

$$R_{tamb} = R_{77°F} \frac{a + t_{amb}}{a + t_{77°F}}$$

$t_{77°F}$: reference temperature = 77°F

t_{amb} : temperature during measurement (°F)

$R_{77°F}$: winding resistance at 77°F

R_{tamb} : winding resistance at t_{amb}

a : Coefficient a = 390

Thermistor Resistance (10k Ohm) for FP1, FP2, HWL, suction line, LAT, LWT and LLT (EWT with Performance Option)		Thermistor Resistance (1k Ohm) for compressor discharge line, compressor ambient and EWT	
Thermistor Temperature (°F)	Thermistor Resistance (Ohms)	Thermistor Temperature (°F)	Thermistor Resistance (Ohms)
5	75757-70117	20	974.4-973.4
14	57392-53234	25	985.4-984.4
23	43865-40771	30	996.1-995.1
32	33809-31487	35	1007.0-1006.0
41	26269-24513	40	1017.8-1016.8
50	20570-19230	45	1028.6-1027.6
59	16226-15196	50	1039.5-1038.5
68	12889-12093	55	1050.2-1049.2
77	10310-9688	60	1061.2-1060.2
86	8300-7812	65	1072.9-1071.9
95	6723-6337	70	1082.7-1081.7
104	5480-5172	75	1093.4-1092.4
113	4490-4246	80	1103.0-1102.0
122	3700-3504	85	1115.5-1114.5
131	3067-2907	90	1126.2-1125.2
140	2554-2424	95	1136.6-1135.6
149	2149-2019	100	1147.2-1146.2
		105	1158.1-1157.1
		110	1168.8-1167.8
		115	1179.4-1178.4
		120	1190.1-1189.1
		125	1200.3-1199.3
		130	1212.2-1211.2

11/30/22

11/30/22

Reference Calculations

Heating Calculations:	Cooling Calculations:
$LWT = EWT - \frac{HE}{\text{gpm} \times 500}$	$LWT = EWT + \frac{HR}{\text{gpm} \times 500}$
$LAT = EAT + \frac{HC}{\text{cfm} \times 1.08}$	$LAT (DB) = EAT (DB) - \frac{SC}{\text{cfm} \times 1.08}$
$TH = HC + HW$	$LC = TC - SC$
	$S/T = \frac{SC}{TC}$

Legend

Abbreviations and Definitions

cfm	= airflow, cubic feet/minute
EWT	= entering water temperature, Fahrenheit
gpm	= water flow in gallons/minute
WPD	= water pressure drop, psi and feet of water
EAT	= entering air temperature, Fahrenheit (dry bulb/wet bulb)
HC	= air heating capacity, MBtu/h
TC	= total cooling capacity, MBtu/h
SC	= sensible cooling capacity, MBtu/h
kW	= total power unit input, kilowatts
HR	= total heat of rejection, MBtu/h
HE	= total heat of extraction, MBtu/h
HWC	= hot water generator capacity, MBtu/h
EER	= Energy Efficient Ratio = Btu output/Watt input
COP	= Coefficient of Performance = Btu output/Btu input
LWT	= leaving water temperature, °F
LAT	= leaving air temperature, °F
TH	= total heating capacity, MBtu/h
LC	= latent cooling capacity, MBtu/h
S/T	= sensible to total cooling ratio
DH	= Dehumidification
SST	= Saturated Suction Temperature
HPC	= Head Pressure Control
MHGR	= Modulating Hot Gas Reheat
RH	= Reheat

Operating Limits

Operating Limits	Cooling		Heating	
	(°F)	(°C)	(°F)	(°C)
Air Limits				
Min. Ambient Air	45	7.2	45	7.2
Rated Ambient Air	80	26.7	70	21.1
Max. Ambient Air	100	37.8	85	29.4
Min. Entering Air	50	10.0	40	4.4
Rated Entering Air db/wb	80.6/66.2	27/19	68	20.0
Max. Entering Air db/wb	110/83	43/28.3	80	26.7
Water Limits				
Min. Entering Water	30	-1.1	20	-6.7
Normal Entering Water	50-110	10-43.3	30-70	-1.1
Max. Entering Water	120	48.9	90	32.2

NOTE: Minimum/maximum limits are only for start-up conditions, and are meant for bringing the space up to occupancy temperature. Units are not designed to operate at the minimum/maximum conditions on a regular basis. The operating limits are dependent upon three primary factors: 1) water temperature, 2) return air temperature, and 3) ambient temperature. When any of the factors are at the minimum or maximum levels, the other two factors must be at the normal level for proper and reliable unit operation.

Preventative Maintenance

Water Coil Maintenance

1. Keep all air out of the water. An open loop system should be checked to ensure that the well head is not allowing air to infiltrate the water line. Lines should always be airtight.
2. Keep the system under pressure at all times. It is recommended in open loop systems that the water control valve be placed in the discharge line to prevent loss of pressure during off cycles. Closed loop systems must have positive static pressure.

NOTE: On open loop systems, if the installation is in an area with a known high mineral content (125 PPM or greater) in the water, it is best to establish with the owner a periodic maintenance schedule so the coil can be checked regularly. Should periodic coil cleaning be necessary, use standard coil cleaning procedures which are compatible with either the cupronickel or copper water lines. Generally, the more water flowing through the unit the less chance for scaling.

Other Maintenance

Filters

Air filters and variable speed drive filter must be clean to obtain maximum performance. They should be inspected monthly under normal operating conditions and be replaced when necessary. Units should never be operated without a filter. The VS drive filter is located on the lower left corner of the cabinet. Removing the two screws in the honey comb grill allows access to the filter. Run the filter under warm water and gently rub. Let the filter dry. Re-install the filter and cover.

Condensate Drain

In areas where airborne bacteria produce a slime in the drain pan, it may be necessary to treat chemically to minimize the problem. The condensate drain can pick up lint and dirt, especially with dirty filters. Inspect twice a year to avoid the possibility of overflow.

Blower Motors

ECM blower motors are equipped with sealed ball bearings and require no periodic oiling.

Hot Water Generator Coil

See Water Coil Maintenance section above.

PinnaCoil™ Air Coil

The air coil must be cleaned to obtain maximum performance. Check once a year under normal operating conditions and, if dirty, brush or vacuum (with a brush attachment) clean. Care must be taken not to damage the aluminum fins while cleaning.



CAUTION: Fin edges are sharp.

Replacement Procedures

Obtaining Parts

When ordering service or replacement parts, refer to the model number and serial number of the unit as stamped on the serial plate attached to the unit. If replacement parts are required, mention the date of installation of the unit and the date of failure, along with an explanation of the malfunctions and a description of the replacement parts required.

In-Warranty Material Return

Material may not be returned except by permission of authorized warranty personnel. Contact your local distributor for warranty return authorization and assistance.

Troubleshooting

Aurora Control System

NOTE: Refer to the Aurora Base Control Application and Troubleshooting Guide and the Instruction Guide: Aurora Interface and Diagnostics (AID) Tool for additional information.

To check the unit control board for proper operation:

1. General Check
 - If any new device was installed, or any wiring was changed, check the connections to ensure the wiring is correct, and all the wires are in good condition.
 - Verify all the plugs are securely connected and in good condition.
 - Check the DIP switch (SW2) positions are correct.
 - Measure 24 VAC between R and C. (The actual reading may be from 18 to 30 VAC). Check the incoming power and the power transformer if the R and C voltage reading is not correct.
2. No LEDs are On
 - Check 24 VAC on board.
 - Check the 3 amp fuse. Replace the fuse if needed.
 - Verify transformer circuit breaker has not tripped if no low voltage is present.
 - Disconnect the thermostat connection P1.
 - Replace the Aurora base control board.

Reheat Valve (OptiDry Option Only)

Ensure proper wire location on the terminals and that all wires are tightened accordingly before proceeding to troubleshooting steps.

Test the valve:

The resistance of the motor winding may be tested without opening the system.

1. Remove power from the external controller and IB-G.
2. Remove valve leads from the IB-G.
3. Measure the resistance between black and white leads of the valve.
 - *the resistance should be $75\Omega \pm 10\%$ to $100\Omega \pm 10\%$ at 71°F (21.7°C).
4. Measure the resistance between the green and red leads. This value should be within $\pm 5\%$ of the resistance between the black and white leads recorded in step 3.
5. Measure the resistance from any lead to the valve body. Resistance should be infinite (open).

Refrigerant Systems

Refrigerant pressures are monitored by the control system; to maintain sealed circuit integrity, do not install service gauges unless pressure sensor is suspected to be inoperative. Compare the change in temperature on the air side as well as the water side to the Unit Operating Parameters tables. If the unit's performance is not within the ranges listed, make sure the airflow and water flow are correct. Check superheat and subcooling with an AID Tool. If superheat and subcooling are outside recommended ranges, an adjustment to the refrigerant charge may be necessary.

NOTE: Refrigerant tests must be made with hot water generator turned "OFF". Verify that air and water flow rates are at proper levels before servicing the refrigerant circuit. For OptiDry option, MHGR valve is inactive during system performance validation.

Aurora Interface Diagnostic (AID) Tool

Aurora Input-Output Diagnostics



Troubleshooting the Aurora logic board can be accomplished using nothing more than a couple of jumper wires and a volt meter. The process can be simplified with the use of the Aurora Interface Diagnostic Tool (AID Tool). The AID Tool allows the user to see lockout and fault history information, thermostat inputs, sensor inputs, system outputs, timer, etc.

Aurora ABC Checkout

Before replacing the Aurora ABC control board the proper troubleshooting steps must be taken to ensure that the board is the root cause. On the following pages are several flow charts that will assist in checking the control board. If it is found that the control board is faulty, contact technical services for a replacement part.

Blower Speed Selection Number	PWM %	Dehumidification PWM %
1	2	2
2	11	3
3	19	9
4	31	20
5	41	28
6	52	37
7	60	44
8	68	51
9	78	59
10	89	69
11	95	74
12	98	76

LED Displays

Slow Flash = 1 second on and 1 second off

Fast Flash = 100 ms on and 100 ms off

Flash Code = 100 ms on and 400 ms off with a 2 second pause between packages

SW1 Operation

Holding SW1	Description of Operation	LED
2 to 5 sec	Enter Test Mode	Green LED Slow Flash
5 to 10 sec	Enter ECM Configure Mode	Yellow LED Off
50 to 60 sec	Reset Configure Mode (default)	Yellow LED Off
> 60 sec	SW1 Operation Cancel	Yellow LED Back to Normal

“SW1 operation cancel,” holding SW1 for longer than 60 seconds operation will be cancelled. Yellow LED will go back to normal operation.

Fault Retries Before Lockout

Type of Fault	Total Tries Before Lockout
High Pressure	3 Retries
Low Pressure	3 Retries
Freeze Detection 1 - (Coax)	3 Retries
Freeze Detection 2 - (Air coil)	3 Retries
Condensate Overflow	3 Retries
Over/Under Voltage Shutdown	No Lockout
Compressor Monitor	No Retry
Freeze Detection Sensor Error (Sensor is out of range)	No Retry

Preliminary Checkout Procedure

Troubleshooting liquid source heat pumps with Aurora controls is an easy and straight forward process. Most service problems are related to water flow (insufficient or too cold). Also, most service problems can be fixed without connecting refrigerant manifold gauges.

The first item to check is system performance which can be done in six steps. Before beginning make sure the hot water generator pump is disconnected.

STEP 1: Check and/or set source water flow. Refer to the install manual for the specific piece of equipment’s correct water flow setting.

STEP 2: Check the temperature difference through the coaxial heat exchanger and compare to the Operating Parameters table in the equipment install manual.

STEP 3: Check the air temperature rise/drop and compare to the Operating Parameters table in the equipment’s installation manual.

STEP 4: If the first three steps check out, perform a heat of extraction/rejection test as described in the Water Side Analysis: Heat of Extraction/Rejection section to confirm proper operation.

STEP 5: If any or all of the above steps do not check out, be sure that the air coil and filter are clean.

STEP 6: Check superheat and subcooling by placing refrigeration gauges on the unit. Compare superheat and subcooling values with the charts in the equipment installation manual.

If the above six steps do check out, it would be safe to assume that the unit is performing well and the problem must lie elsewhere, i.e. excessive heat loss/gain in the structure or duct system, (undersized duct and/or registers, etc.)

If you suspect a specific problem, refer to the Table of Contents and select the reference that most closely matches the situation encountered. If problems persist after completing the preliminary checkout procedure, refer to the Troubleshooting Checklist. Select the problem which is closest to the situation you have encountered.

Aurora Fault/Alarm Codes (ABC-Red LED)

Aurora now expands the Fault/Alarms in to several groups.

- Faults are system critical faults to the heat pump and will cause a Lockout. Some are retried 3 times before locking out while others lockout out immediately. Consult the Fault Retries table before lockout for details.
- Alarms are designed solely to alert the customer and the dealer to alarms designed as an input only to the Aurora system. These alarms are not system critical.
- Errors are sensor/hardware errors that although may not be system critical, may need serviced for optimal features.
- **SafeMode** - the system is still operational during safemode however the compressor is restricted to 2400 rpm (speed 5).
- **Derating Mode** - the system is operating, but out-of-range condensing, evaporating, drive current or supply voltage operating conditions are causing the drive to self-limit the capacity output and bring the unit back into more normal operating parameters until a solution occurs to the adverse condition.

Summary Table of Faults, Alarm, and Errors

All lockouts and alarms are shown in the Status LED (LED1, Red) table with the associated codes visible on the thermostat, ABC Fault LED, and in text in the AID Tool.

Aurora Fault Codes (ABC-Red LED)

These fault codes generally will affect the operation of the heat pump and will cause a lockout.

E1, Fault Input - A Y1/Y2 style thermostat is providing a non-normal sequence of signals possibly caused by a bad thermostat wire or connection.

E2, High Pressure - Fault is recognized when the Normally Closed High Pressure Switch, P4-9/10 opens, no matter how momentarily. The High Pressure Switch is electrically in series with the Compressor Contactor and serves as a hardwired limit switch if an overpressure condition should occur.

E3, Low Pressure - Fault is recognized when the Normally Closed Low Pressure Switch, P4-7/8 is continuously open for 30 seconds. Closure of the LPS any time during the 30 second recognition time restarts the 30 second continuous open requirement. A continuously open LPS shall not be recognized during the 2 minute startup bypass time.

E3, Loss of Charge - Fault is recognized when the Normally Closed Low Pressure Switch, P4-7/8 is open prior to the compressor starting.

E4, Freeze Detection-Air Coil - Air Coil Freeze Detection will use the FP2 input to protect against ice formation on the air coil. The FP2 input will operate exactly like FP1 except that the set point is 30 degrees and is not field adjustable.

E5, Freeze Detection-Coax - Set points shall be either 30°F or 15°F. When the thermistor temperature drops below the selected

set point, the control shall begin counting down the 30 seconds delay. If the thermistor value rises above the selected set point, then the count should reset. The resistance value must remain below the selected set point for the entire length of the appropriate delay to be recognized as a fault. This fault will be ignored for the initial 2 minutes of the compressor run time.

E7, Condensate Overflow - Fault is recognized when the impedance between this line and 24 VAC common or chassis ground drops below 100K ohms for 30 seconds continuously.

E8, Over/Under Voltage Shutdown - An over/under voltage condition exists when the control voltage is outside the range of 18 VAC to 30 VAC. If the over/under voltage shutdown lasts for 15 minutes, the lockout and alarm relay will be energized. Over/under voltage shutdown is self-resetting in that if the voltage comes back within range of 18 VAC to 30 VAC for at least 0.5 seconds, then normal operation is restored.

E10, Compressor Monitoring - Fault is recognized when the compressor has an open circuit, potential welded contactor.

E11, FP1 Sensor Error - Fault is recognized when the impedance between this line and 24 VAC common or chassis.

E14, Critical AXB Sensor Error - Fault is recognized when a sensor faults that is critical to heat pump operation. These sensors would include the HW Temperature limit sensor.

E15, Alarm Hot Water - Fault is recognized when the hot water temperature sensor is either over the configured limit or the Aurora has determined the current conditions should disengage the hot water generation capability limit.

E16, Variable Speed Pump - Fault is recognized when the variable speed pump returns a fault code from its PWM feedback signal.

E19, Critical Communication Error - A critical communication error has occurred with a board that previously had been configured but now is not available for communication. Since this is critical to unit operation, the heat pump will be locked out with this fault displayed on the ABC board and the thermostat. The AID Tool should be used to view the configuration window and ascertain the status of all appropriate board communication. The fault displayed will be removed when the problem has been resolved or the unit is soft or hard reset.

E51, Drive Fault - Discharge Temperature Invalid - The reading of the discharge temperature sensor (Sd) is >280°F or is not within the specified sensor range of -60 to +200°C (-76 to +392°F). Possible causes are faulty wiring or a defective sensor. The system will go to safe mode speed and return to normal operation, when the problem has been resolved.

E52, Drive Fault - Suction Pressure Invalid - The reading of the suction pressure transmitter is not within the specified sensor range

Aurora Fault/Alarm Codes (ABC-Red LED) cont.

of 0 to 16bar (0 to 232psi). Possible causes are faulty wiring or a defective transmitter. The system will go to safe mode speed and return to normal operation, when the problem has been resolved.

E53, Drive Fault - Condenser Pressure - Invalid - The reading of the condenser pressure transmitter is not within the specified sensor range of 0 to 50bar (0 to 725psi). Possible causes are faulty wiring or a defective transmitter. The system will go to safe mode speed and return to normal operation, when the problem has been resolved.

E54, Drive Fault - Low Supply Voltage - The supply voltage has dropped below 180V and the drive has stopped the compressor. When the supply voltage has recovered to at least 190V, the drive will resume operation possibly with derating of the output power. This fault does not require soft or hard reset. Powering off/on too quickly (<30 sec.) can also cause this fault.

E56, Drive Fault - Over Current - The drive has encountered an over current event and has stopped operation. An over current can be triggered by a number of different events, such as motor phase loss, locked rotor, short circuit or ordinary overload condition. The drive will stop the compressor and will attempt 5 times to auto restart the system after waiting 2 minutes. If more than 5 events occur within 1 hour then the drive will go into a trip lock condition and it becomes necessary to cycle power to the drive and to perform a reset to restart the system. In case of an earth fault, the drive goes immediately into a trip lock condition and will not attempt to restart the system.

E57, Drive Fault - Over/Under Voltage - The DC Link voltage in the drive has reached a critical low level (<185vdc) or high level (>450vdc) and has stopped operation. When the DC link voltage has recovered, the drive resumes operation. A voltage condition can happen due to a mains failure. The drive will attempt to auto-restart the system after 2 minutes. This fault does not require soft or hard reset.

E58, Drive Fault - Over Temperature - The drive has encountered an over temperature condition and has stopped operation (trip lock). An over temperature occurs when the temperature measured inside the drive has reached a critical level (>115°C / 239°F). Possible causes are insufficient cooling due to a defective cooling fan, blocked air circulation or extreme high ambient temperature. To restart the system, it is necessary to cycle power to the drive and to perform a reset.

E59, Drive Fault - Internal Error - The drive has encountered an internal error, e.g. missing communication between the microprocessors. The drive goes immediately into a trip lock condition. To restart the system, it is necessary to cycle power to the drive and to perform a reset, however it is likely that the drive will not recover from this condition.

E61, Multi Safe Mode - More than one Safe Mode condition is present requiring lockout.

E71, EEV Fault - Loss of Charge (LOC) - The EEV sensors have determined that the unit has experienced a severe loss of charge and will be locked out.

Aurora Error Codes

NOTE: The system is operating normally, but a sensor or communication issue is preventing full features of the system. Since these can be deemed non-critical to system operation, such as internet access boards etc., they may simply cause errors/alerts that signal the user to the situation but may not effect normal operation.

E13, Non Critical AXB Sensor Error - Fault is recognized when a sensor faults that is not critical to heat pump operation. These sensors would include the performance, energy monitoring and refrigeration sensors.

E18, Error Non-Critical Communication Error - A non-critical communication error has occurred such as communication to the internet access board. Since this is not critical to unit operation, the heat pump will continue operating normally with this error displayed on the ABC board and the thermostat. The AID Tool should be used to view the configuration window and ascertain the status of all appropriate board communication. The Error displayed will be removed when the problem has been resolved.

E55, Drive Fault - Out of Envelope - The automatic derating functions were unable to bring the operating point back into the compressor envelope. After operating outside the envelope for more than 90 seconds (low suction pressure 60 sec.), the system stops and issues an alarm. The drive will attempt to auto-restart the system after 2 minutes. Note that some E55 faults can be generated by low loop temperatures in cooling frequently which is experienced in the spring time. These will not result in a full lockout. The Aurora will alter compressor speed to avoid the E55 condition but these events will still be visible in the E55 history.

Aurora Derating Codes

NOTE: the system is operating, but out-of-range condensing, evaporating, drive current or supply voltage operating conditions is causing the drive to self-limit the capacity output and bring the unit back into more normal operating parameters until a solution occurs to the adverse condition. It is possible for some situations to progress from Derating to SafeMode to finally locking out due to a fault.

E41, Derating Drive - High Drive Temperature -The temperature measured in the drive's power electronics has reached a critical level (>239°F/115°C) and the drive cannot maintain full capacity output. Therefore the drive slows the compressor down until the temperature is no longer critical. When temperatures have normalized the drive will attempt to return to normal operation.

Aurora Fault/Alarm Codes (ABC-Red LED) cont.

E42, Derating Drive - High Discharge Temperature - The compressor discharge temperature (Sd) has reached a critical high value (>280°F/138°C). To decrease the discharge temperature, the drive has slowed down the compressor. When the temperature has normalized the drive will attempt to return to normal operation.

E43, Derating Drive - Low Suction Pressure - The suction pressure (PO) has reached a critical low value. To make the suction pressure recover, the drive has slowed down the compressor. When the pressure has normalized the drive will attempt to return to normal operation.

E44, Derating Drive - Low Condenser Pressure - The condenser pressure (Pc) has reached a critical low value (<119psig). If the condenser pressure remains at a critical low level after the start up sequence, the drive reports an alarm. This alarm indicates that the system may have encountered a loss of charge. If this alarm is subsequently reported 10 times the drive goes into a trip lock condition.

E45, Derating Drive - High Condenser Pressure - The condenser pressure (Pc) has reached a critical high value (>654psig). To decrease the condenser pressure, the drive has slowed down the compressor. When the pressure has normalized the drive will attempt to return to normal operation.

E46, Derating Drive - Output Power Limit - The supply voltage has dropped below 208V or an extreme operating condition, e.g. high condensing pressure has activated the derating function limiting the output power of the drive. The drive will return to normal operation when the supply voltage has recovered or operating conditions have normalized.

Aurora SafeMode Codes

NOTE: The system is still operational during safemode, however the compressor is restricted to 2400 rpm (speed 6). It is possible for some situations to progress from Derating to SafeMode to finally locking out due to a fault.

E47, SafeMode Drive - EEV Indoor Failure - The communication with the indoor EEV controller has been interrupted and the EEV controller has switched to independent mode to maintain the requested superheating. The system will go to safe mode speed and return to normal operation when communication has been re-established.

E48, SafeMode Drive - EEV Outdoor Failure - The communication with the outdoor EEV controller has been interrupted and the EEV controller has switched to independent mode to maintain the requested superheating. The system will go to safe mode speed and return to normal operation when communication has been re-established. Not used in GSHP.

E49, SafeMode Drive - Ambient Temperature Invalid - The reading of the ambient temperature sensor (Samb) is not within the specified sensor range of -60 to +100°C (-76 to +212°F). Possible causes are faulty wiring or a defective sensor. The system will go to safe mode speed and return to normal operation, when the problem has been resolved.

E72, SafeMode EEV - Suction Temperature Invalid - The reading of the suction temperature sensor is not within the specified sensor range of -60 to +200°C (-76 to +392°F). The EEV will be positioned at 50% and the compressor will be operated at 2400 rpm in SafeMode until rectified. Possible causes are faulty wiring or a defective sensor. The system will go to safe mode speed and return to normal operation, when the problem has been resolved.

E73, SafeMode EEV - Leaving Air Temperature (LAT) Invalid - The reading of the leaving air temperature sensor is not within the specified sensor range of -60 to +200°C (-76 to +392°F). Normal operation will continue with an Error 73 display on the thermostat to notify the user of the issue. Possible causes are faulty wiring or a defective sensor. The Error displayed will be removed when the problem has been resolved.

E74, SafeMode EEV - Maximum Operating Pressure (MOP) - The reading of the suction pressure is above the recommended limit. If this condition persists more than 90 seconds, the Drive will revert to a Fault - Out of Envelope Code 35. The system will continue to operate in SafeMode at 2400 rpm until the situation is resolved or the drive has fault on an out of envelope condition.

Aurora Alarm Codes

These alarms are planned to alert the homeowner and the service personnel but will NOT effect system operation and are for information only. These would be available on the thermostat, AID Tool and the internet access for remote monitoring capability.

E21, Loop Pressure Alarm - Fault is recognized when the loop pressure sensor is installed and the loop pressure falls below the setpoint.

E23 and E24, Home Automation 1 and 2 Inputs - The Home automation inputs are simple 24VAC inputs that will trigger an AID Tool and thermostat alert for the homeowner. These would require optional sensors and or equipment for connection to the AXB board. With two inputs, two different sensors can be selected. The selected text will then be displayed on the AID Tool and com thermostats. These events will NOT alter functionality or operation of the heat pump/accessories and is for homeowner/ service notification only. With a closed dry contact signal, this input will cause an alarm E23 or E24 to indicate on the stat or flash on ABC. The AID Tool will allow configuration of these two inputs independently between the following selections:

- No Action
- Home Automation Fault [no lockout, info only] - Output from home automation system
- Security Alarm [no lockout info, only] - Output from home security
- Sump Alarm Fault [no lockout info, only] - Switch output from sump sensor
- Smoke/CO Alarm Fault [no lockout info, only] - Switch output from Smoke/CO sensor
- Dirty Filter Alarm [no lockout info, only] - Output from dirty filter sensor

Troubleshooting Checklist

Equipment will not start or operate

- Follow the troubleshooting flow charts to find root cause.

High pressure lockout in the heating mode

- Check for air flow interruption from one or more of the following: inoperative blower, dirty filters or air coil, blocked return air grill, closed or blocked supply registers, restricted supply or return duct, zone dampers, etc. If airflow is suspected as being a problem, make a quick check using the following example: Velocity in a supply duct should not exceed 1000 fpm and 700 fpm in return ducts. For this example we will use a Variable Speed Q36 which has a maximum rating of 1575 cfm at 0.50 static (Refer to the blower performance tables in the install manual for your particular piece of equipment). Using the formula: Area in square feet equals quantity in cfm divided by velocity in fpm ($A = \text{cfm}/\text{fpm}$), 1.57 sq. ft. is needed for the supply duct and 2.25 sq. ft. is needed for the return duct. Refer to the troubleshooting flow charts if a problem with the blower motor or logic board is suspected.
- Check for EEV operation. EEV opening percentage should change as compressor speed changes.
- Make sure the discharge pressure is within the operating range shown in the product install manual.
- The unit may be overcharged; check superheat and sub cooling. If this problem is verified, recharge using approved methods.

High pressure lockout in the cooling mode

- Water flow may be restricted or inadequate. Verify in accordance with the pressure drop tables shown in product install manual. Also, look for the following: solenoid valve may not be opening on well water units, pump(s) may be inoperative in the flow center, debris may be blocking coil (back flush using at least 20 PSI), or air may be in the loop (flush loop). Variable speed pump may not be setup properly.
- Water to refrigerant heat exchanger may be fouled with debris. If so, back flush with at least 20 psi of water pressure.
- If mineral accumulation is evident, clean the heat exchanger with acid.
- Entering air temperature may be too high. Equipment is designed for a maximum of 85°F DB and 71°F WB.
- Check for EEV operation. EEV opening percentage should change as compressor speed changes.
- The unit may be overcharged; check superheat and sub cooling. If this problem is verified, recharge using approved methods.

Low pressure lockout in heating mode

- If equipment is installed in a low temperature area (below 50°F), install a crankcase heater, then protect the unit from the elements.

- Water flow may be restricted or inadequate. Verify in accordance with the pressure drop tables shown in product install manual. Also, look for the following: solenoid valve may not be opening on well water units, pump(s) may be inoperative in the flow center, debris may be blocking coil (back flush using at least 20 PSI), or air may be in the loop (flush loop). Variable speed pump may not be setup properly.
- Check for EEV operation. EEV opening percentage should change as compressor speed changes.
- Return air temperature may be below 50°F. Block off air coil temporarily to improve flow of refrigerant through the system. Air below 50°F cannot be tolerated on a continuing basis. Correct the problem.
- Refrigerant may be low. Check for leaks, reclaim refrigerant, repair if necessary, recharge using approved methods.

Low pressure lockout in the cooling mode

- Check for inadequate air flow. Follow the same procedure as shown for a high pressure lockout in the heating mode.
- Check for EEV operation. EEV opening percentage should change as compressor speed changes.
- Refrigerant charge may be low.

Freeze detection lockout in either the heating or cooling mode

- Water flow may be restricted or inadequate. Verify in accordance with the pressure drop tables shown in product install manual. Also, look for the following: solenoid valve may not be opening on well water units, pump(s) may be inoperative in the flow center, debris may be blocking coil (back flush using at least 20 PSI), or air may be in the loop (flush loop). Variable speed pump may not be setup properly.
- Disconnect freeze sensor from control and measure the resistance. Cross reference with the Thermistor Data table.
- Airflow may be inadequate.

Condensate over flow lockout in either the heating or cooling mode

- Make sure the drain line pitches away from the unit. Install a vertical vent on horizontal drain lines over six feet long. Clean condensate pan and be sure outlet and drain line from the condensate pan is clear.

Reversing valve does not operate

- Disconnect solenoid and check for continuity across coil. Replace coil if continuity is not found.
- If stuck reversing valve is suspected, restrict airflow in heating mode (to build pressure), then switch immediately to the cooling mode.

Control Board Troubleshooting Steps

1) General Check

- If any new device was installed, or any wiring was changed, check the connections to ensure the wiring is correct, and all the wires are in good condition.
- Verify all the plugs are securely connected and in good condition.
- Check the DIP switch (SW2) positions are correct.
- Measure 24 VAC between R and C. (The actual reading may be from 18 to 30 VAC). Check the incoming power and the power transformer if the R and C voltage reading is not correct.

2) No LEDs are On

- Check 24 VAC on board.
- Check the 3 amp fuse. Replace the fuse if needed.
- Verify transformer circuit breaker has not tripped if no low voltage is present.
- Disconnect the thermostat connection P1.
- Replace the Aurora base control board.

3) Red LED Flash Code

Input Fault (Code 1) – Indicates that both O and W input signals are present. Disconnect the thermostat connector from the ABC board and then cycle power to the board. If the fault does not reappear, then the problem is between the thermostat and the thermostat connector. Otherwise, replace the ABC board.

High Pressure Fault (Code 2) – Indicates the system pressure has exceeded 600 psi (R-454B) which may have been caused by low water flow in cooling, (check coaxial heat exchanger for mineral build-up) or low air flow in heating (check filters and coil for dirt build-up). Measure P4-9 and C is 24 VAC. If not, replace ABC. Check the heat pump refrigeration system. Cycle the power to reset the system. Measure P4-10 and C is 24 VAC. If not, replace the high pressure sensor.

Low Pressure Fault (Code 3) – Indicates low pressure switch has opened which may indicate a loss of system charge, system restriction, or frozen heat exchanger. Measure P4-7 and C is 24 VAC. If not, replace ABC. Check the heat pump refrigeration system. Cycle the power to reset the system. Measure P4-8 and C is 24 VAC. If not, replace the low pressure sensor. Refrigerant may be low. Check for leaks, reclaim refrigerant, repair if necessary, pump down and recharge the system to the quantity of refrigerant shown on the unit nameplate.

Freeze Detection 1 Fault (Code 5) – Indicates low or no water flow; low system charge; or faulty EEV in heating mode. Make sure the DIP switch FP1 (SW2-1) selection matches the application. Measure the temperature on the refrigerant line next to the freeze detection thermistor. Disconnect the connector P4. Measure the resistance reading between P4-3, P4-4. Refer to the Thermistor Data table, find the corresponding temperature data. Compare the data with the temperature

measurement from the refrigerant line. The temperature should be within +/- 2° F. If not, replace the thermistor.

Other items to check when troubleshooting a water flow lockout are superheat, water flow through the coaxial heat exchanger and antifreeze composition. High superheat in heating will lower the refrigerant line temperature where the freeze detection thermistor is located. In this case, check the EEV. Closed loop systems are rated at 3 gpm/ton. If a closed loop system is running at less than 3 gpm/ton, the temperature difference between the refrigerant line and the actual leaving water temperature will be greater and could lead to possible water flow lockouts.

Condensate Fault (Code 7) – Indicates condensate water in the drain pan fills up and touches the spade terminal. Make sure the drain line pitches away from the unit. Install a vertical vent on horizontal drain lines over six feet long. Clean and be sure outlet and drain line from the condensate pan is clear. Start the system in cooling. Observe the water level in the drain pan. If the unit is locking out on condensate and the drain pan is dry, remove the condensate wire from the drain pan and tape it out of the way. Be careful to not ground the wire out because that will cause the unit to lockout on drain overflow. If the unit is still locking out, check the brown wire all the way back to the ABC for a short to ground. Remember that the condensate sensor is just a wire looking for a ground. If it touches any metal in the cabinet, the unit will see that as a drain fault. If removing the wire from the drain pan stopped the false drain lockouts, put the condensate sensor back in place in the drain pan. Pay close attention to how far the spade terminal sits down in the drain pan. If the terminal is pushed all the way down so that it is touching the bottom of the drain pan, this will cause a drain lockout if there is any trace of water. If the spade terminal fits loosely in the drain pan, spread the terminal open to make it fit snugly in the drain pan.

Over/Under Voltage Shutdown Fault (Code 8) – Indicates the control voltage is or had been outside the range of 18 to 30 VAC for more than 15 minutes. Using a voltage meter, check the incoming power line voltage is within + or - 25%. If not, there is a power line issue. Check the secondary of the control transformer with a voltage meter. The voltage should be 18 to 30 VAC. If not, replace the control transformer.

Freeze Detection FP1 Sensor Fault (Code 11) – Indicates the freeze detection sensor is out of range. Disconnect the connector P4. Measure the resistance reading between P4-3, P4-4. Refer to the Thermistor Data table, find the corresponding temperature data. Compare the data with the temperature measurement from the refrigerant line. The temperature should be within +/- 2°F. If not, replace the thermistor.

Control Board Troubleshooting Steps

4) Other Faults

ECM Motor Will Not Start

1. Measure the voltage output between P13-1 and P13-5. Reference the following table for blower speed vs. voltage.

Blower Speed Selection Number	DC Volts
1	0.6 VDC
2	2.7 VDC
3	4.6 VDC
4	7.5 VDC
5	9.8 VDC
6	12.5 VDC
7	14.4 VDC
8	16.3 VDC
9	18.5 VDC
10	21.2 VDC
11	22.3 VDC
12	23.4 VDC

2. Measure the voltage from C to F terminals (P5-2). The reading should be 24VAC.

Compressor First Stage Will Not Start - See the Flow Chart.

No Alarm Output - Measure the voltage output between P2-4 and C. The reading should be 24 VAC or a pulsed 24 VAC dependent on the selection of SW2-7.

Accessory Relay Does Not Operate - Measure the continuity between P2-2 and P2-3. It should read closed when relay is engaged. If this is not correct, check SW2-4 and SW2-5 settings.

No Lockout Output - Measure the voltage output between P1-1 and C. The reading should be 24 VDC or a pulsed 24 VDC dependent on the selection of SW2-7. If voltage is not present, make sure the unit is in lockout and not fault retry.

Auxiliary Heater Does Not Function - Measure the voltage output between P3-1, P3-2, and P3-3, P3-4. The output should be 24 VDC. If voltage is not present, check thermostat operation and wiring.

Loop Pump Does Not Start - The loop pump is controlled by the AXB board. Check to make sure the control board is powered by taking a voltage reading across R and C to check for 24VAC. If 24VAC is not present check the wiring connections, 24VAC is supplied to the AXB through the harness connected to P9. Next check to make sure the ABC is attempting to run the compressor, the loop pump will only run when the ABC is commanding CC on, the pump slave input is active, or the AXB has lost communication with the ABC. Please refer to troubleshooting flow charts for additional checks on the loop pump.

5) Thermistor

Disconnect the thermistor from the board and measure ohms. Compare the ohms reading to the thermistor data chart in this manual. If the thermistor reads open or shorted the thermistor is bad and should be replaced.

6) Pressure Transducer

Check to make sure the board is powering the transducer by checking for 5VDC between the brown and blue wires. If the reading is 0VDC the transducer is not being powered and the board should be replaced. If there is 5VDC present the transducer is powered and the output should be checked. To check the output, measure the DC voltage between the brown and black wires. The value should be between 0.3VDC and 4.5VDC. If it is outside of this range the transducer should be replaced.

7) Flow Meter

Check to make sure the board is powering the transducer by checking for 5VDC between the brown and green wires. If the reading is 0VDC the transducer is not being powered and the board should be replaced. If there is 5VDC present the transducer is powered and the output should be checked. To check the output, measure the DC voltage between the brown and white wires. The value should be between 0.3VDC and 3.3VDC. If it is outside of this range the transducer should be replaced.

8) Current Transducer

Disconnect the current transducer from the board and measure ohms across the two wires. The ohms reading should be approx. 22 ohms.

Control Board Troubleshooting Flow Charts cont.

Use the following flow charts to aid in troubleshooting the control board.

Compressor Will Not Start Without AID Tool

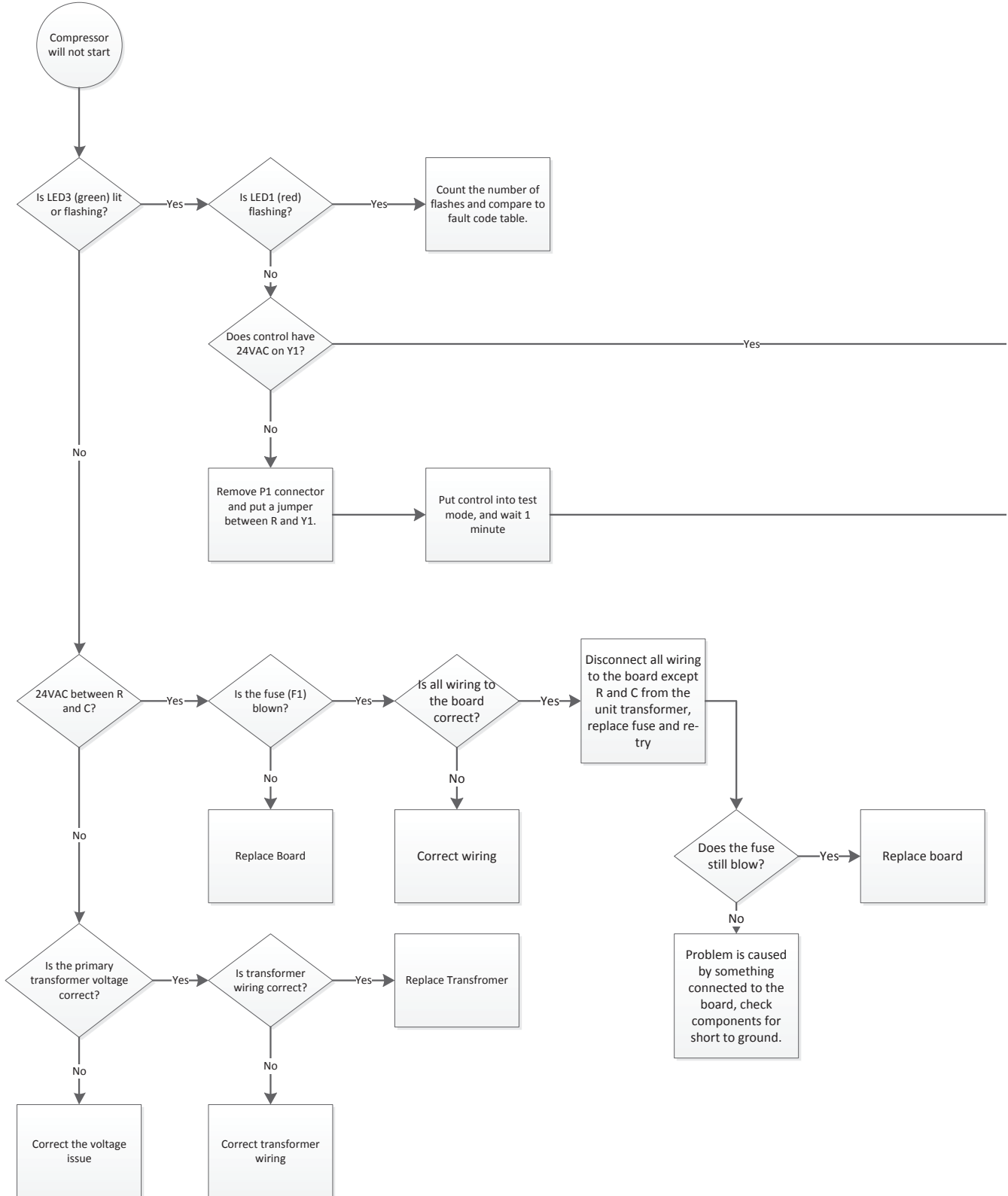

Control Board Troubleshooting Flow Charts cont.

Notes:

1. When measuring 24VAC actual value may be between 18 and 30VAC.

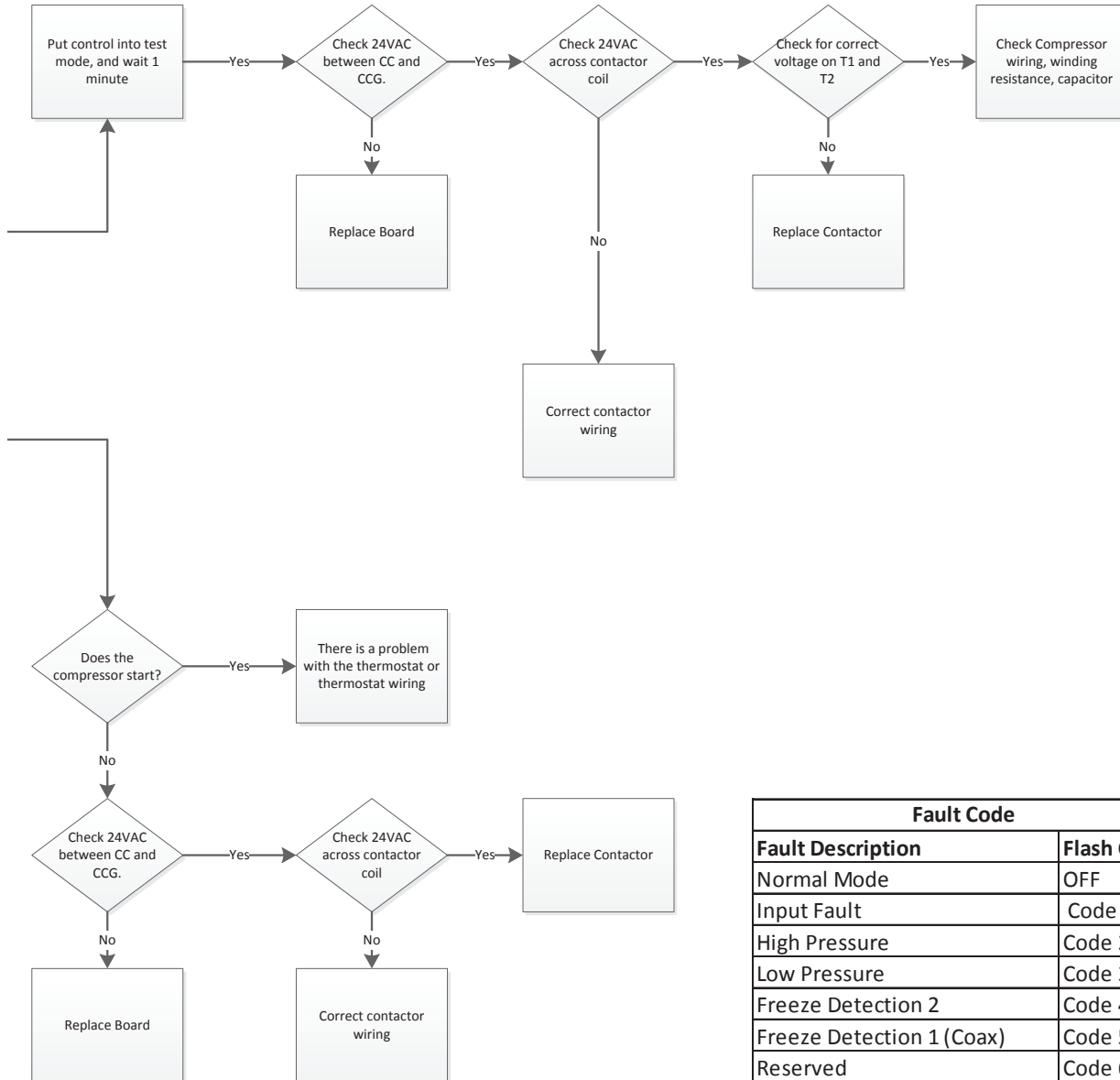

Fault Code	
Fault Description	Flash Code
Normal Mode	OFF
Input Fault	Code 1
High Pressure	Code 2
Low Pressure	Code 3
Freeze Detection 2	Code 4
Freeze Detection 1 (Coax)	Code 5
Reserved	Code 6
Condensate	Code 7
Over/Under Voltage	Code 8
Not Used	Code 9
Freeze Detection Sensor Error	Code 11

NOTE: Refer to the Control Board Troubleshooting Steps for fault descriptions.

Control Board Troubleshooting Flow Charts cont.

Compressor Will Not Start With AID Tool

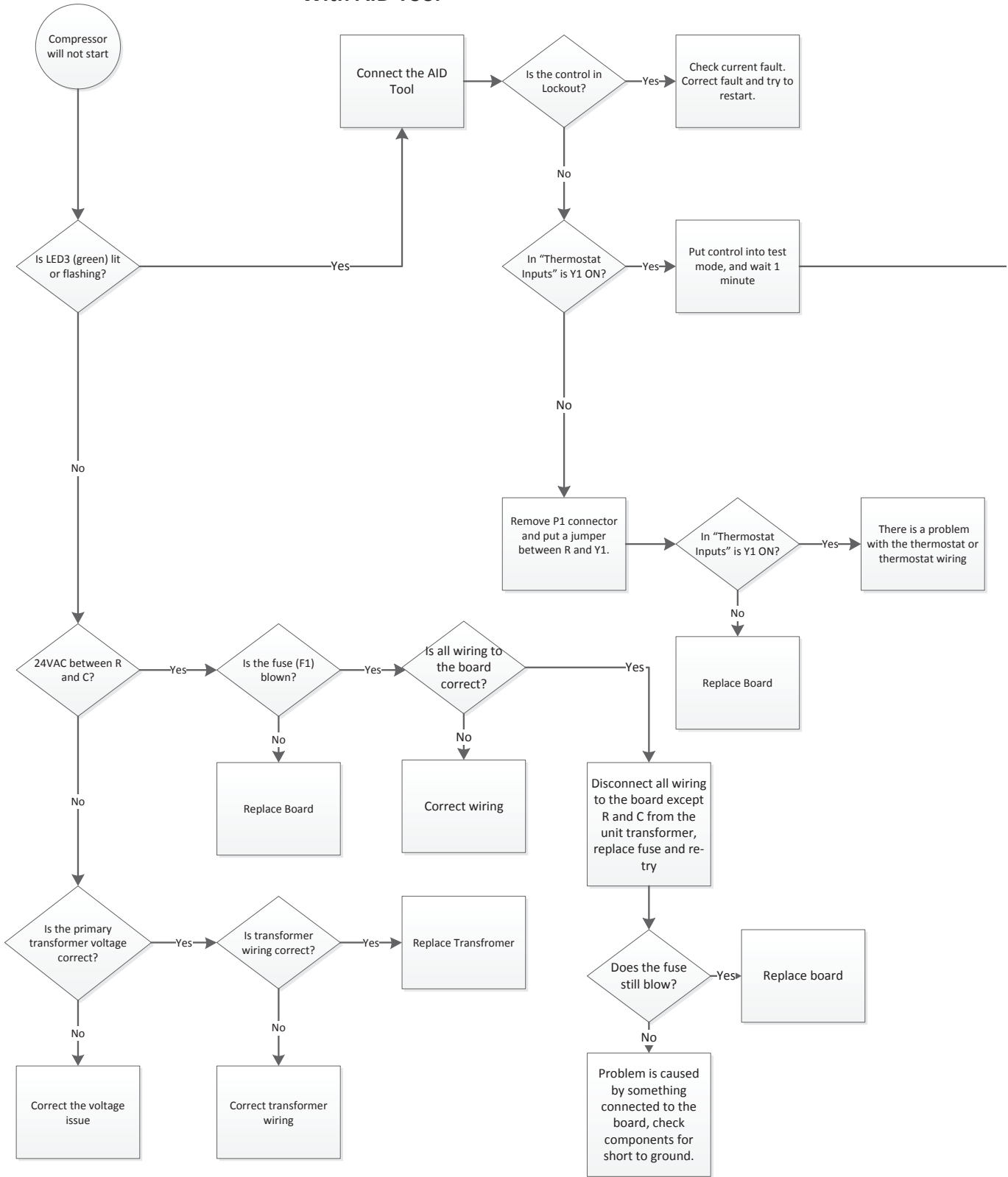

Control Board Troubleshooting Flow Charts cont.

Notes:

1. When measuring 24VAC actual value may be between 18 and 30VAC.

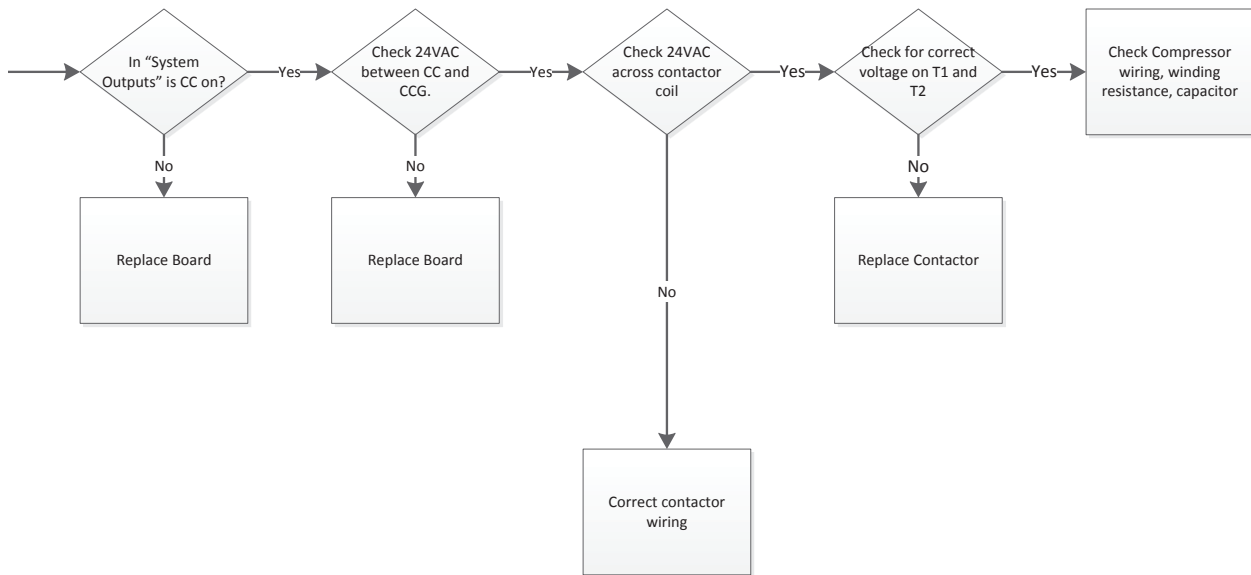

Control Board Troubleshooting Flow Charts cont.

ECM Blower Will Not Start Without AID Tool

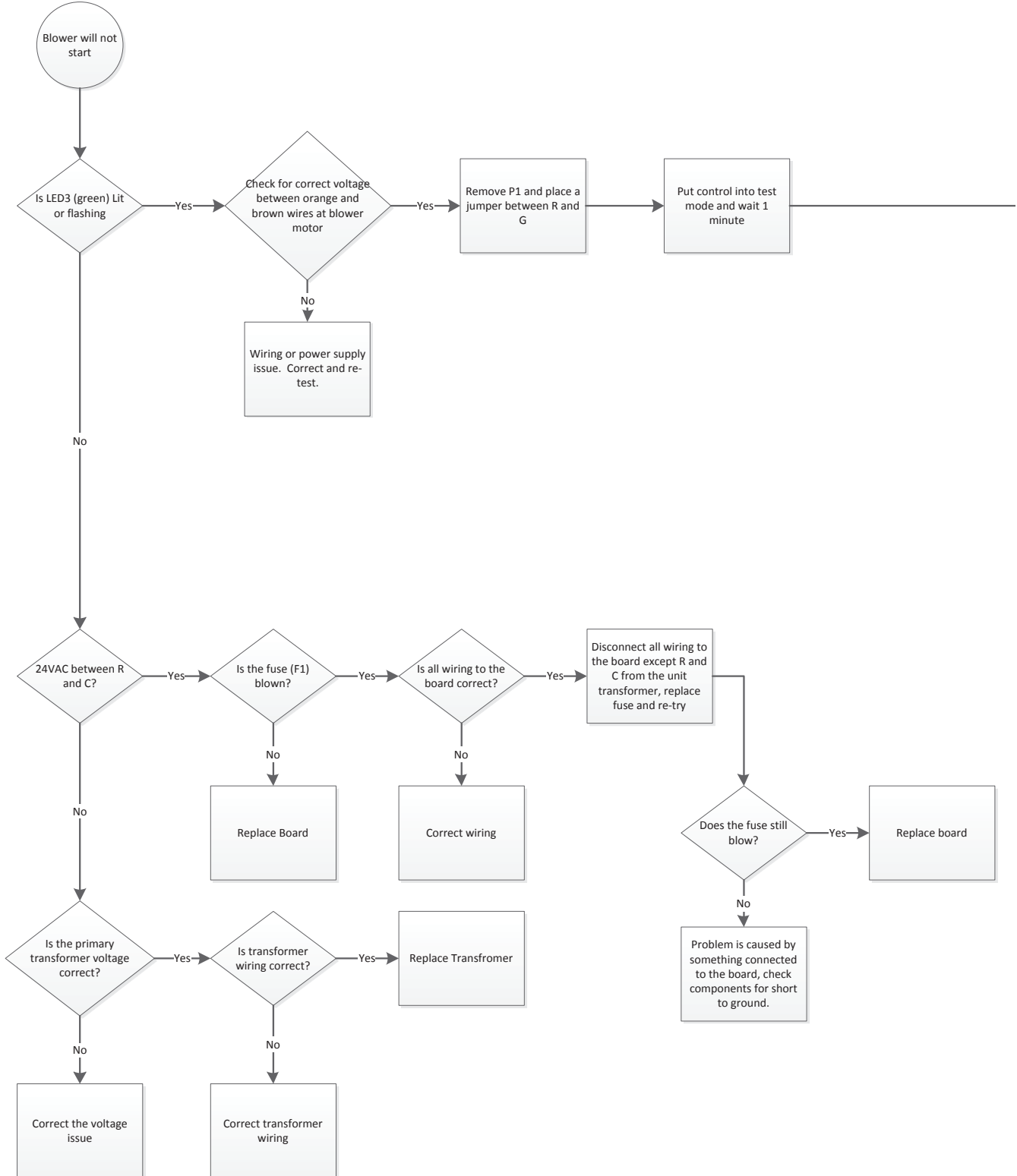

Control Board Troubleshooting Flow Charts cont.

Notes:

1. When measuring 24VAC actual value may be between 18 and 30VAC.

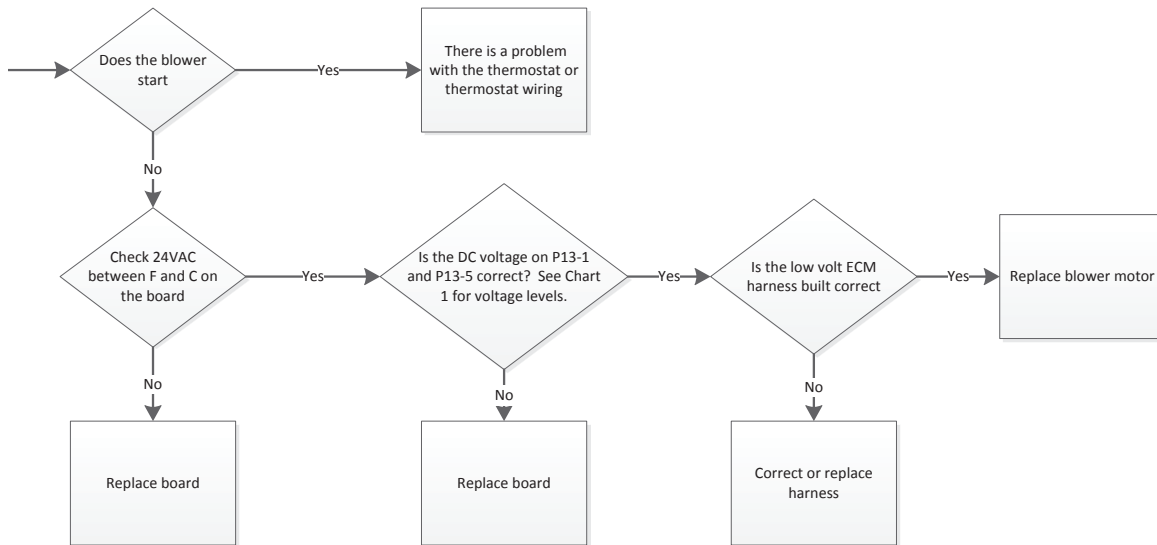

Chart 1

Blower Speed Selection Number	DC Volts
1	0.6VDC
2	2.7VDC
3	4.6VDC
4	7.5VDC
5	9.8VDC
6	12.5VDC
7	14.4VDC
8	16.3VDC
9	18.5VDC
10	21.2VDC
11	22.3VDC
12	23.4VDC

Control Board Troubleshooting Flow Charts cont.

ECM Blower Will Not Start With AID Tool



Control Board Troubleshooting Flow Charts cont.

Notes:

1. When measuring 24VAC actual value may be between 18 and 30VAC.

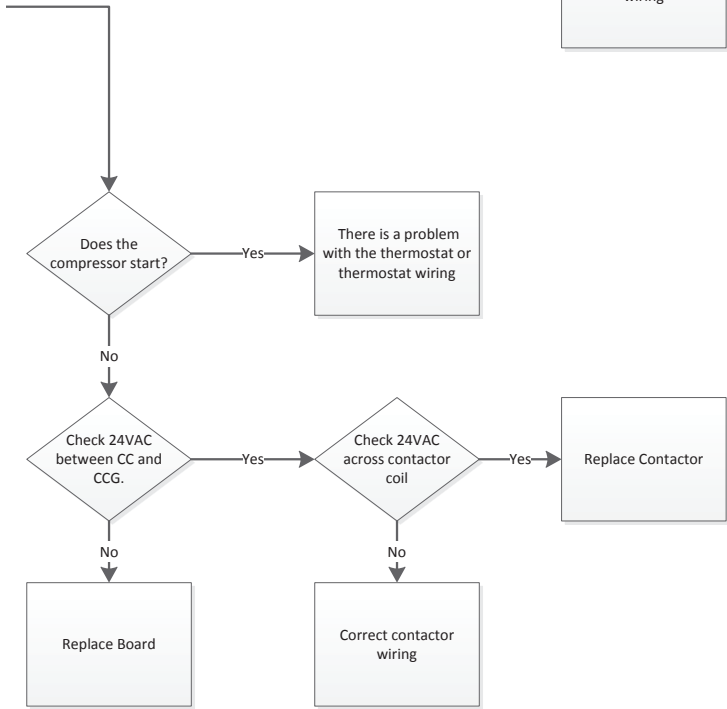
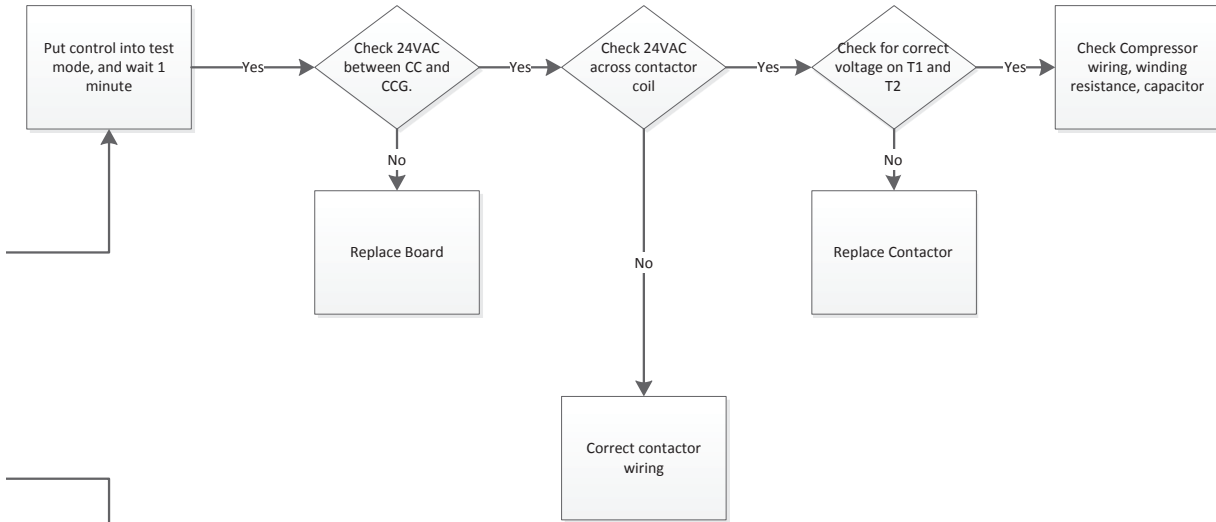

Fault Code	
Fault Description	Flash Code
Normal Mode	OFF
Input Fault	Code 1
High Pressure	Code 2
Low Pressure	Code 3
Freeze Detection 2	Code 4
Freeze Detection 1 (Coax)	Code 5
Reserved	Code 6
Condensate	Code 7
Over/Under Voltage	Code 8
Not Used	Code 9
Freeze Detection Sensor Error	Code 11

Control Board Troubleshooting Flow Charts cont.

Loop Pump Will Not Start Variable Speed Pump

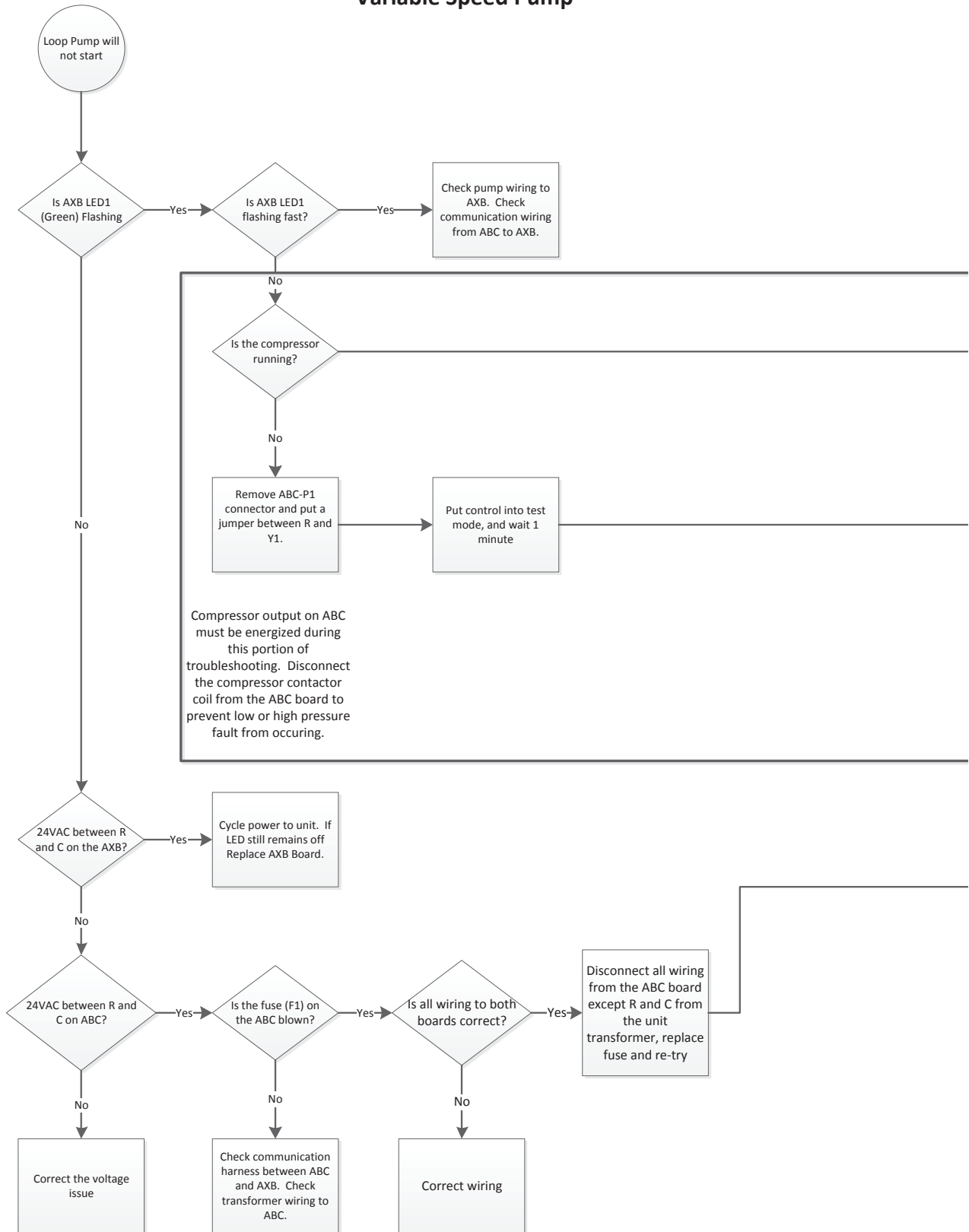

Control Board Troubleshooting Flow Charts cont.

Notes:

1. When measuring 24VAC actual value may be between 18 and 30VAC.
2. When measuring 240VAC actual value may be between 190 and 250 VAC.

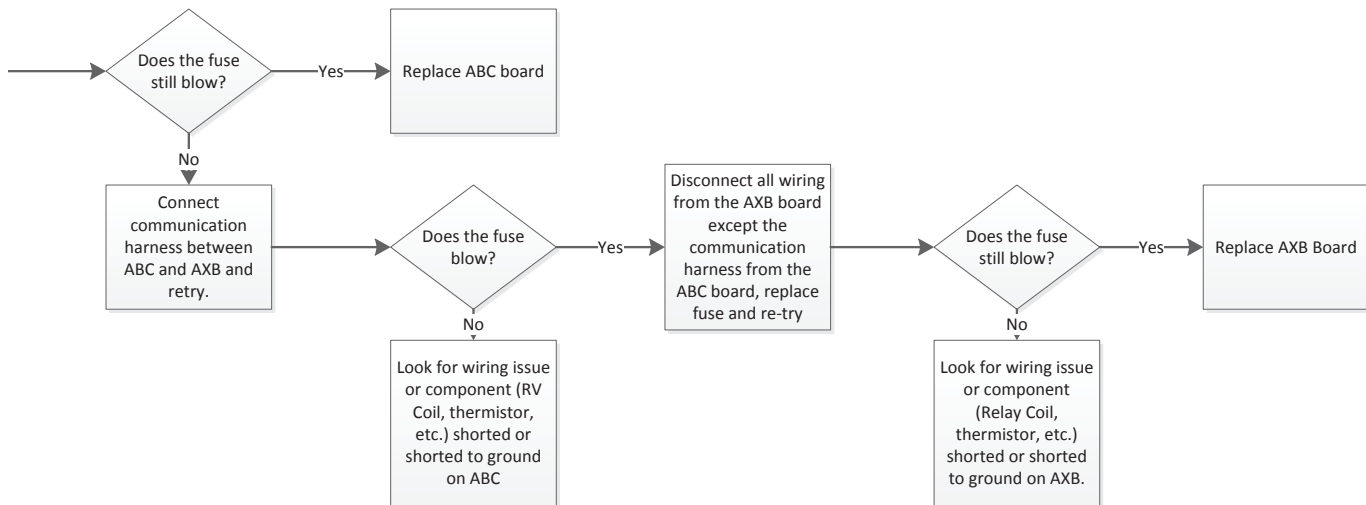
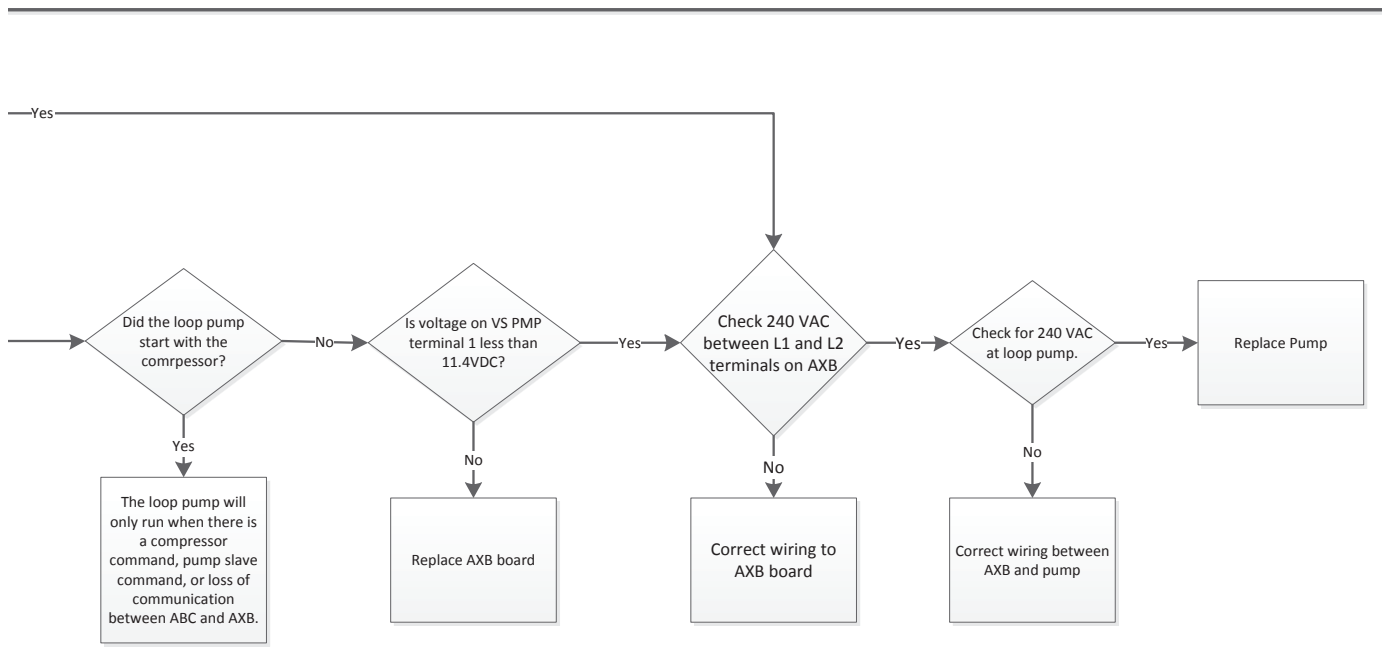

Control Board Troubleshooting Flow Charts cont.

Loop Pump Will Not Start Non Variable Speed Pump



Control Board Troubleshooting Flow Charts cont.

Notes:

1. When measuring 24VAC actual value may be between 18 and 30VAC.
2. When measuring 240VAC actual value may be between 190 and 250 VAC.

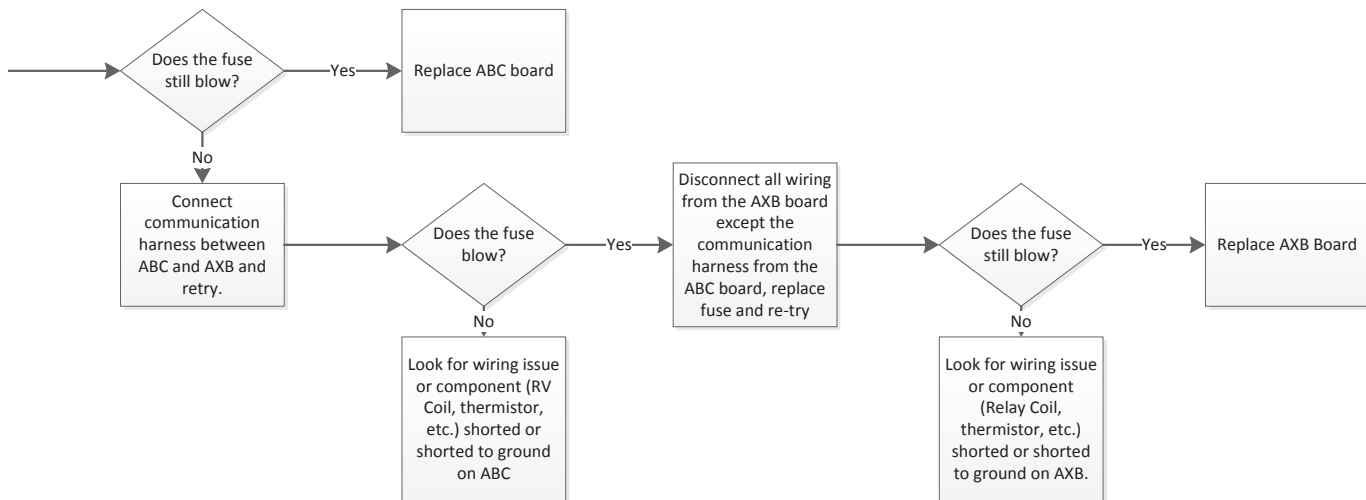
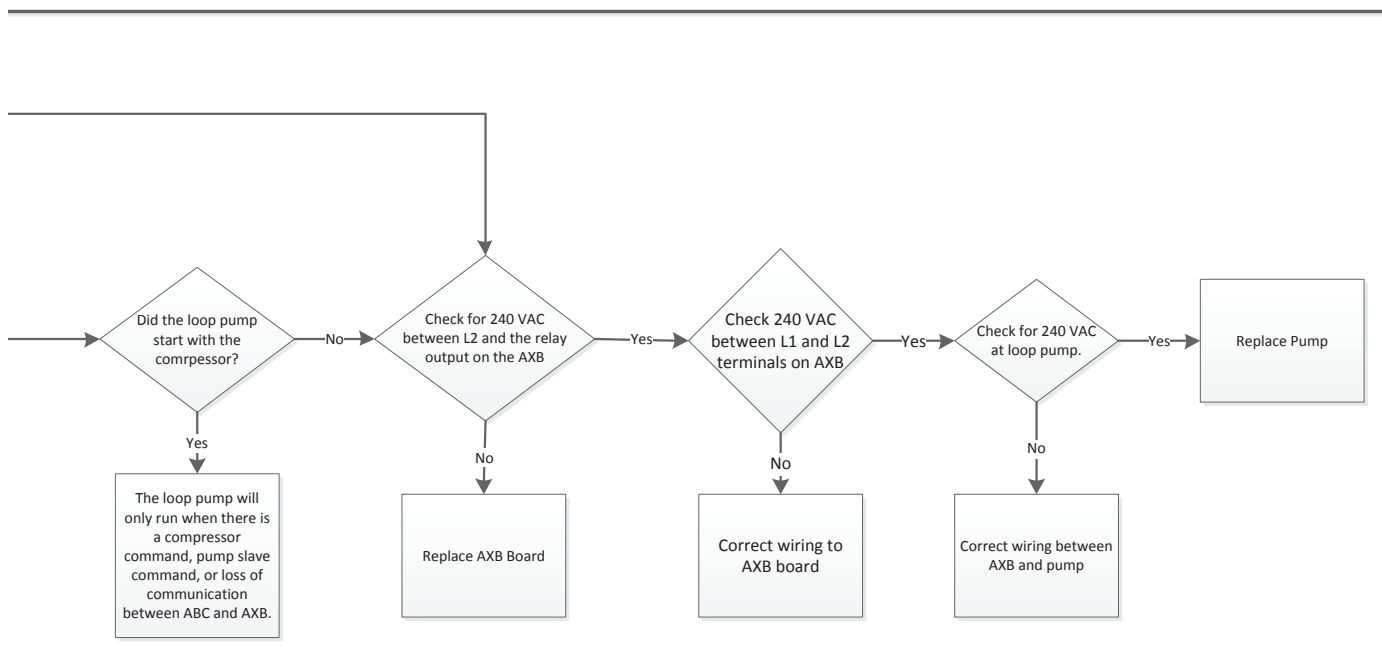

Communicating Thermostat Troubleshooting Guide

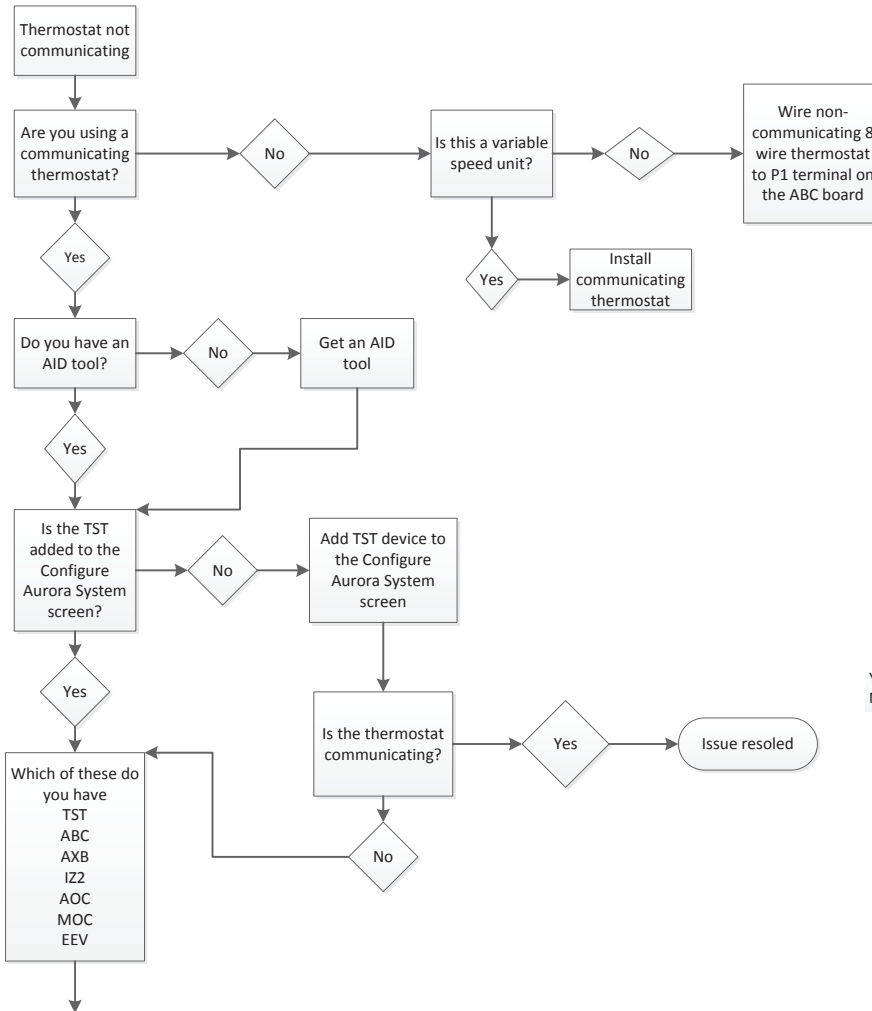

Continue to Next Page

Configure Aurora System Screen

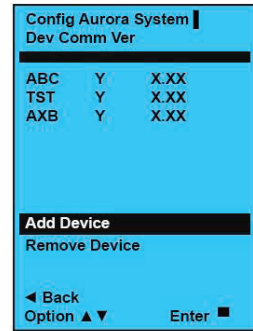

Single and Dual Capacity unit

Y – Active Communication
 N – Device has been found, but communication has failed.

Communicating Thermostat Troubleshooting Guide cont.

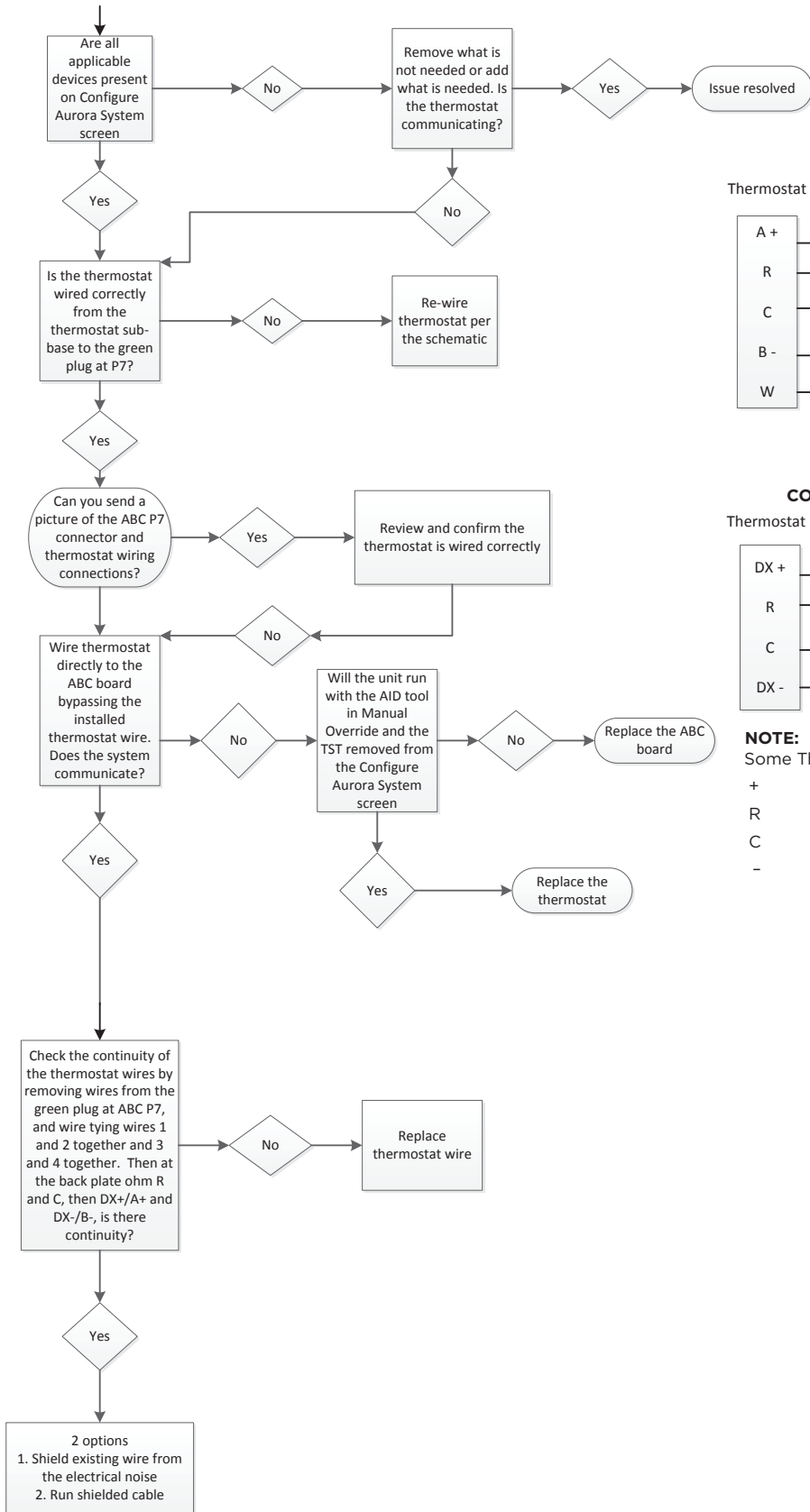

TPCM32U03A*/TPCM32U04A*

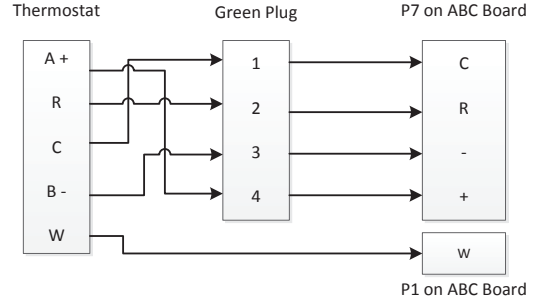

TPCC SERIES
COLOR TOUCHSCREEN THERMOSTAT

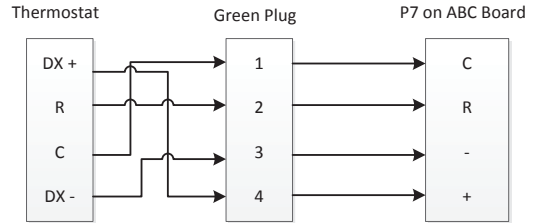

NOTE:
Some Thermostats will be:

- +
- R
- C
-

Control Board Signals

To Check for 24VAC between R and C

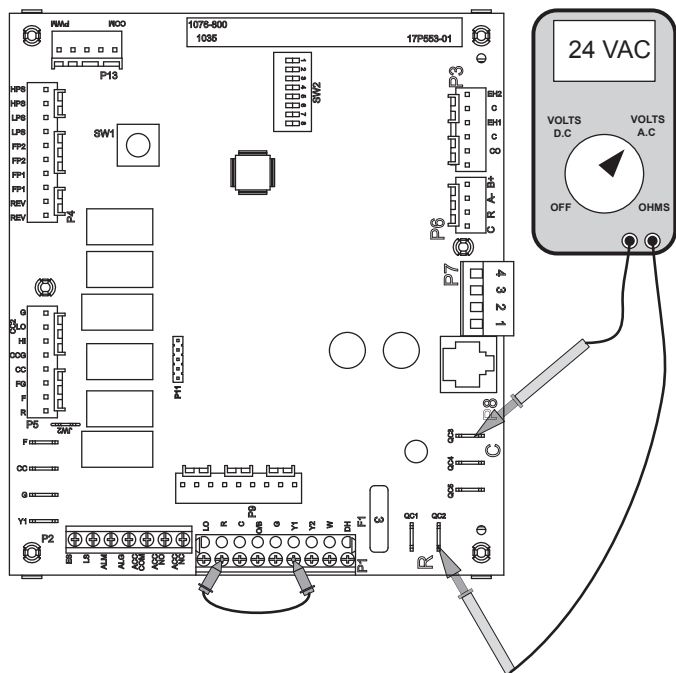

With power applied to the unit connect your Volt meter leads to “R” and “C” on the control board where the yellow and black/white transformer wires connect. The reading should be between 18VAC and 30VAC.

To Check for 24VAC to Compressor Contactor

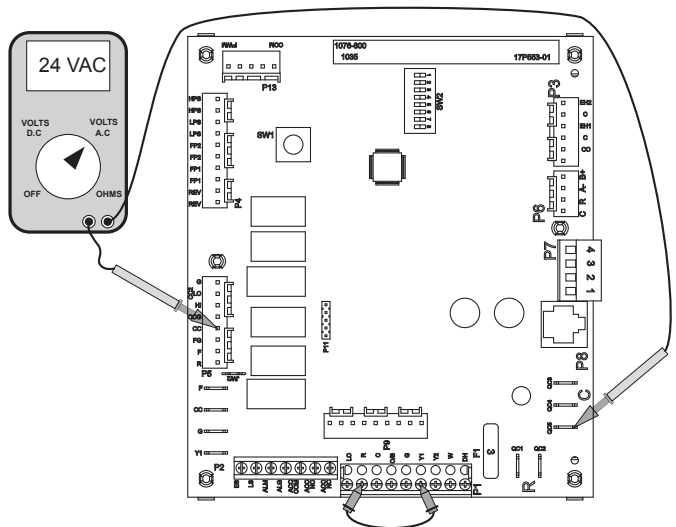

With the AID Tool go to the “Thermostat Inputs” Menu under “Diagnostics” and over-ride the “Y1” input to ON. If an AID Tool is not available remove the P1 connector to disconnect the thermostat from the board and place a jumper wire between “R” and “Y1” as shown. Apply power and put the board into test mode by holding SW1 for 2-5 seconds, the green LED will begin a slow flash. Connect your Volt meter leads to “CC” and “C”. After 1 minute the reading should be between 18 and 30VAC. If you have

a signal and the contactor is not pulled in, check voltage across the contactor coil. If you have voltage across the contractor coil, replace the contactor. If there is no voltage across the contactor coil, verify all wiring between the board and contactor. If you have no voltage between CC and C and the fault LED is not flashing, then replace the board.

To Check Operation of the Reversing Valve Output

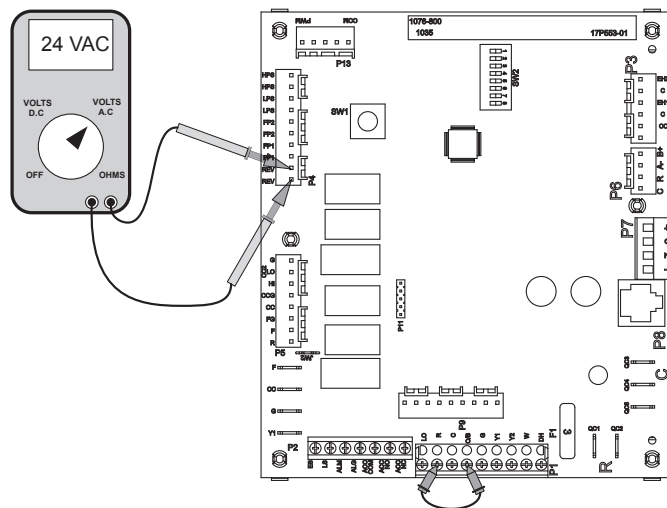

Make sure that SW2-3 is set to “ON”. With the AID Tool go to the “Thermostat Inputs” Menu under “Diagnostics” and over-ride the “O” input to ON. If an AID Tool is not available remove the P1 connector to disconnect the thermostat from the board and place a jumper wire between “R” and “O” as shown. Apply power and put the board into test mode by holding SW1 for 2-5 seconds, the green LED will begin a slow flash. Connect your Volt meter leads to the two “REV” pins on P4. The reading should be between 18 and 30VAC. If you have voltage and the reversing valve is not shifting, check voltage across the coil. If you have voltage across the reversing valve coil, but the valve does not shift the reversing valve coil may be bad. If there is no voltage across the coil, verify all wiring between the board and reversing valve. If no voltage is present on the two REV terminals then replace the board.

Control Board Signals cont.

To Check Operation of the Accessory Relay

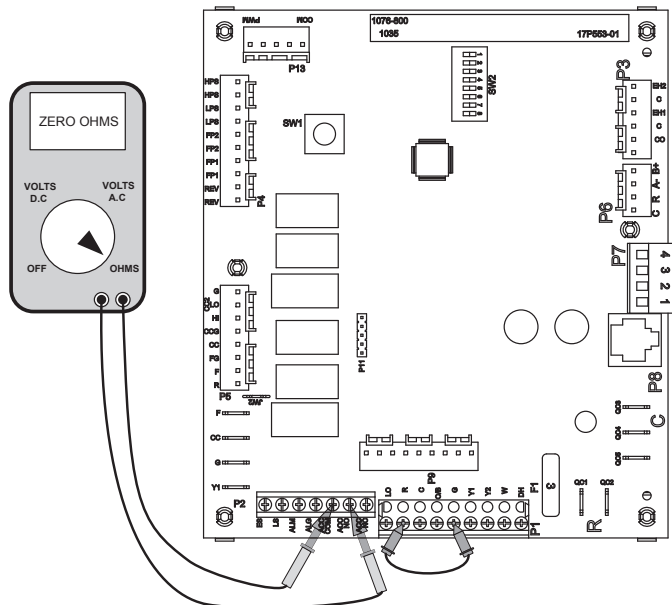

Make sure that SW2-4 and SW2-5 are both set to "ON". With the AID Tool go to the "Thermostat Inputs" Menu under "Diagnostics" and over-ride the "G" input to ON. If an AID Tool is not available remove the P1 connector to disconnect the thermostat from the board and place a jumper wire between "R" and "G" as shown. Apply power and put the board into test mode by holding SW1 for 2-5 seconds, the green LED will begin a slow flash. Connect your Ohm meter leads to the two "ACC COM" and "ACC NO" on P2. A reading of zero ohms indicates that the relay is switching and operating normally. A reading of infinity or open line indicates that the relay did not close and the board should be replaced.

To Bypass the Safety Circuit and Engage the Compressor Contactor

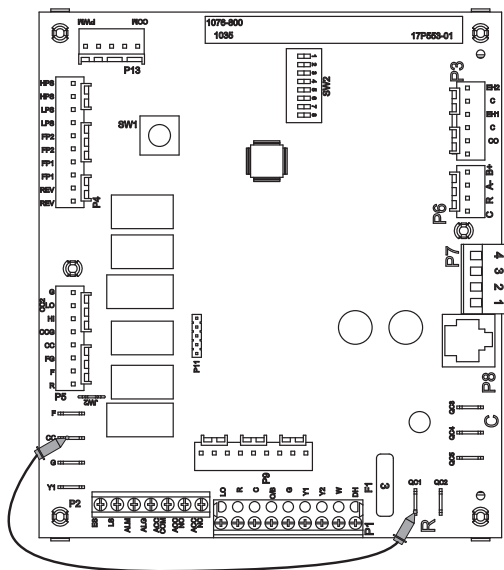

Put gauges on the unit to monitor high/low pressure. Place a jumper between "R" and "CC" as shown. **This will bypass the safety circuit and the compressor will run whether the board is calling for it or not.**

To Check the Freeze Detection Thermistor (AID Tool Required)

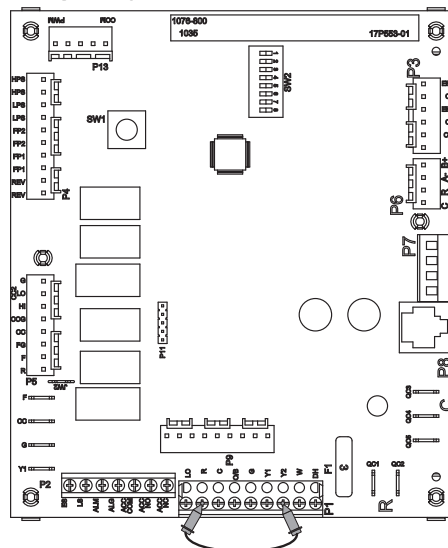

Disconnect the loop pumps so they will not run. Place a thermocouple on the refrigerant line next to the freeze detection thermistor. With the AID Tool go to the "Thermostat Inputs" Menu under "Diagnostics" and over-ride the "Y2" input to ON. If an AID Tool is not available remove the plug on P1 to disconnect the thermostat from the board. Place a jumper on "R" and "Y2" as shown. Apply power and put the board into test mode by holding SW1 for 2-5 seconds, the green LED will begin a slow flash. As the unit runs in second stage heating with the loop pump(s) not working, the lack of water flow will quickly bring down the temperature of the refrigerant line where the freeze detection thermistor is located. Watch the FP1 temperature reading on the AID Tool and compare it with the thermocouple reading. The thermocouple reading and FP1 reading should be within 2 degrees F of each other. If the thermistor is found to be out of calibration, replace the thermistor. Allowing the unit to continue to run will cause a freeze detection fault to occur. Remember, there is a two minute bypass delay and a 30 second recognition delay on the freeze detection input. This means that the compressor will not shut down during the first 2.5 minutes of run time regardless of how low the freeze thermistor reads.

Other items to check when troubleshooting a freeze detection lockout are superheat, water flow through the coaxial heat exchanger, and antifreeze composition. High superheat in heating will lower the refrigerant line temperature where the freeze protection thermistor is located. In this case, check the expansion device. Closed loop systems are rated at 3 gpm/ton. If a closed loop system is running at less than 3 gpm/ton, the temperature difference between the refrigerant line and the actual leaving water temperature will be greater and could lead to possible freeze detection lockouts.

Control Board Signals cont.

To Check the Condensate Sensor

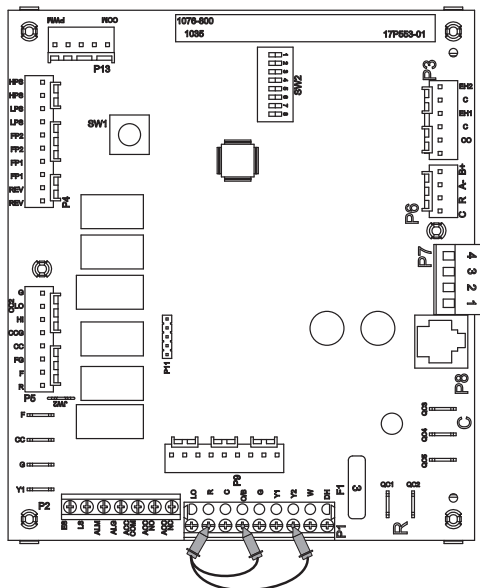

How it works: The condensate sensor is a three part system: a wire, air coil, and water in the drain pan. The wire (spade terminal) and air coil act like a normally open contact and the water acts as the switch. When water in the drain pan fills up and touches the spade terminal, the unit will fault on condensate.

Checking the Sensor: With the AID Tool go to the “Thermostat Inputs” Menu under “Diagnostics” and over-ride the “O” and “Y2” inputs to ON. If an AID Tool is not available remove the P1 connector to disconnect the thermostat from the board and place a jumper wire between “R”, “Y2”, and “O” as shown. Apply power and put the board into test mode by holding SW1 for 2-5 seconds, the green LED will begin a slow flash. Observe the water level in the drain pan. If the unit is locking out on condensate and the drain pan is dry, remove the condensate wire from the drain pan and tape it out of the way. Be careful not to ground the wire out because that will cause the unit to lockout on condensate over flow. If the unit is still locking out, check the brown wire all the way back to the logic board for a short to ground. Remember that the condensate sensor is just a wire looking for a ground. If it touches any metal in the cabinet, the unit will see that as a condensate fault.

If removing the wire from the drain pan stopped the false drain lockouts, put the condensate sensor back in place in the drain pan. Pay close attention to how far the spade terminal sits down in the drain pan. If the terminal is pushed all the way down so that it is touching the bottom of the drain pan, this will cause a condensate lockout if there is any trace of water in the drain pan. If the spade terminal fits loosely in the drain pan, spread the terminal open to make it fit snugly in the drain pan.

To Check the ECM Blower Motor Enable Signal

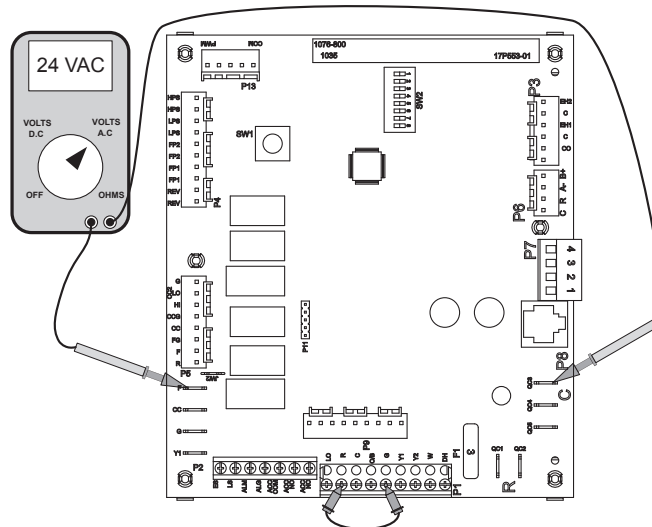

With the AID Tool go to the “Thermostat Inputs” Menu under “Diagnostics” and over-ride the “G” input to ON. If an AID Tool is not available remove the P1 connector to disconnect the thermostat from the board and place a jumper between “R” and “G” as shown. Put the board into test mode by holding SW1 for 2-5 seconds. The blower will come on and run in the “G” speed setting. To check the enable signal to the motor, measure 24VAC between the F and C terminals.

To Check the Electric Heat Outputs

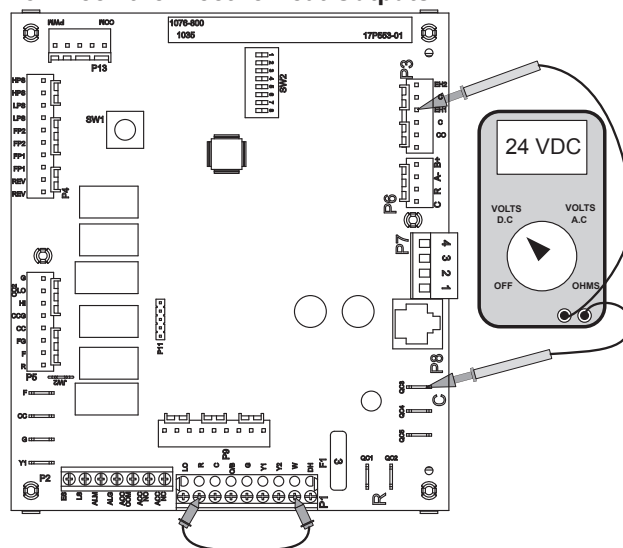

With the AID Tool go to the “Thermostat Inputs” Menu under “Diagnostics” and over-ride the “W” input to ON. If an AID Tool is not available remove the P1 connector to disconnect the thermostat from the board and place a jumper between “R” and “W” as shown. Put the board into test mode by holding SW1 for 2-5 seconds. The blower will come on and run in high speed. 10 seconds later electric heat output 1 (EH1) will be enabled followed by electric heat output 2 (EH2) in 7.5 seconds. Check EH1 by measuring DC volts between “C” and “EH1” and check EH2 by measuring DC volts between “C” and “EH2”.

Jumping the Control Board cont.

Emergency Heat

With the AID Tool go to the “Thermostat Inputs” Menu under “Diagnostics” and over-ride the “W” input to ON. If an AID Tool is not available remove the P1 connector to disconnect the thermostat from the board. Place a jumper between the “R” and “W” terminals as shown.

The blower will start on high speed and after 20 seconds the first stage of resistance heat is energized. Continuing demand will engage the second stage after 2 minutes.

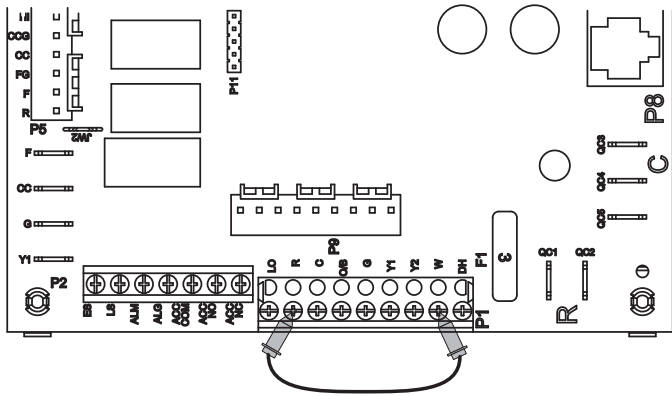

Stage 1 Cooling

With the AID Tool go to the “Thermostat Inputs” Menu under “Diagnostics” and over-ride the “Y1” and “O” inputs to ON. If an AID Tool is not available remove the P1 connector to disconnect the thermostat from the board. Place a jumper between the R, O, and Y1 terminals as shown.

The blower motor will start in “G” blower speed setting immediately, the compressor will start 10 seconds later. If the unit is equipped with an ECM blower motor it will switch to low speed 15 seconds after the Y1 input.

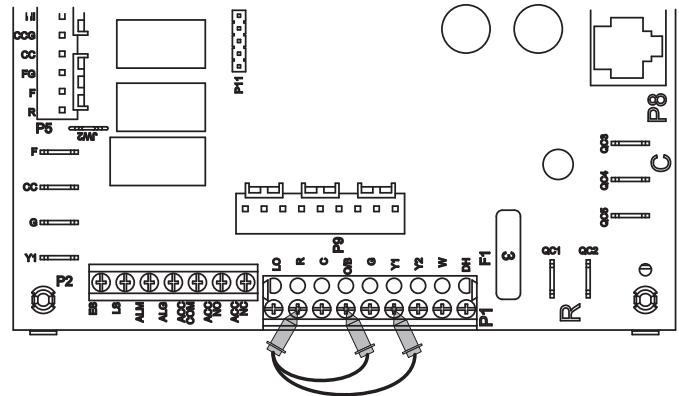

Blower Only

With the AID Tool go to the “Thermostat Inputs” Menu under “Diagnostics” and over-ride the “G” input to ON. If an AID Tool is not available remove the P1 connector to disconnect the thermostat from the board. Place a jumper between the “R” and “G” terminals as shown.

The blower will start on the “G” speed setting. Also, regardless of blower speed setting, the blower will remain on for 30 seconds at the end of each heating, cooling, emergency heat, or reheat cycle.

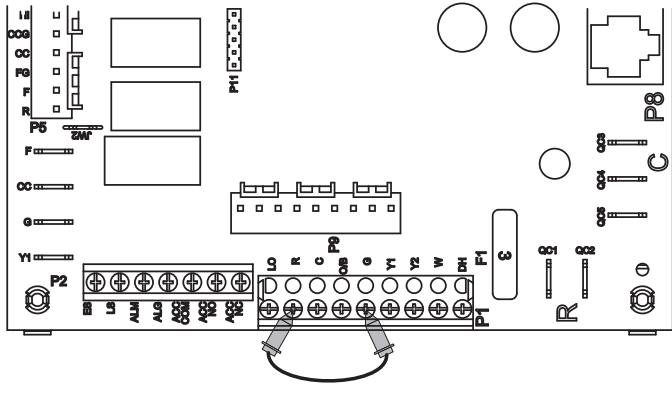

Stage 2 Cooling

With the AID Tool go to the “Thermostat Inputs” Menu under “Diagnostics” and over-ride the “Y1”, “Y2”, and “O” inputs to ON. If an AID Tool is not available remove the P1 connector to disconnect the thermostat from the board. Place a jumper between the R, O, Y1, and Y2 terminals as shown.

The blower motor will start in “G” blower speed setting immediately the compressor will start 10 seconds later. If the unit is equipped with an ECM blower motor it will switch to low speed 15 seconds after the Y1 input. The compressor will stage to full capacity 20 seconds after the compressor starts, and the blower will change to high speed.

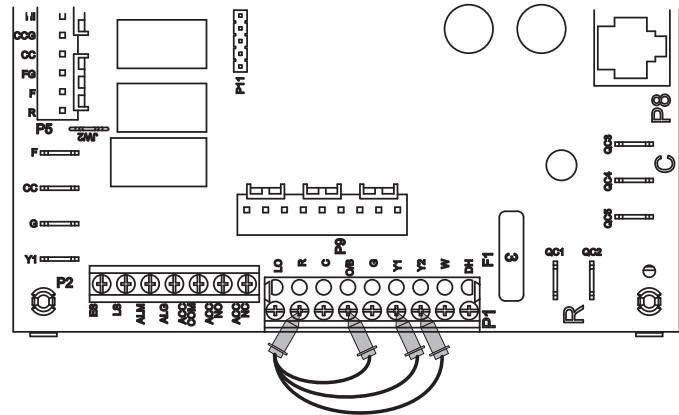

Jumping the Control Board cont.

Reheat Mode

With the AID Tool go to the “Thermostat Inputs” Menu under “Diagnostics” and over-ride the “DH” input to ON. If an AID Tool is not available remove the P1 connector to disconnect the thermostat from the board. Place a jumper between the R and DH terminals as shown.

The blower motor will start in “G” blower speed setting immediately the compressor will start 10 seconds later. If the unit is equipped with an ECM blower motor it will switch to low speed 15 seconds after the DH input. 20 seconds after the DH input is received the compressor will switch to full capacity and the blower motor will switch to dehumidification high speed. 30 seconds after the compressor starts the alarm/reheat output will energize.

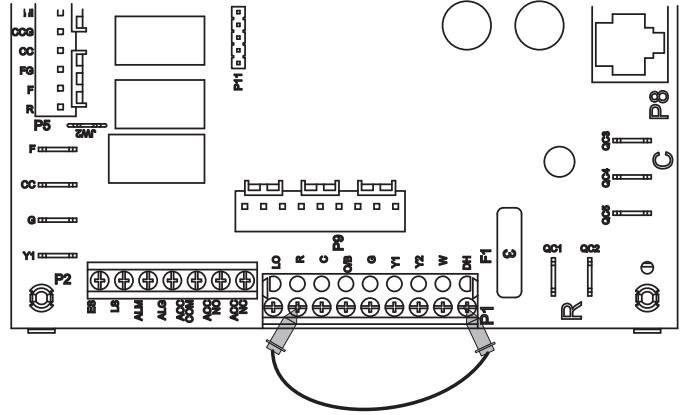

Troubleshooting

Sensor Locations

NOTE: Sensor locations are the same for OptiDry option.

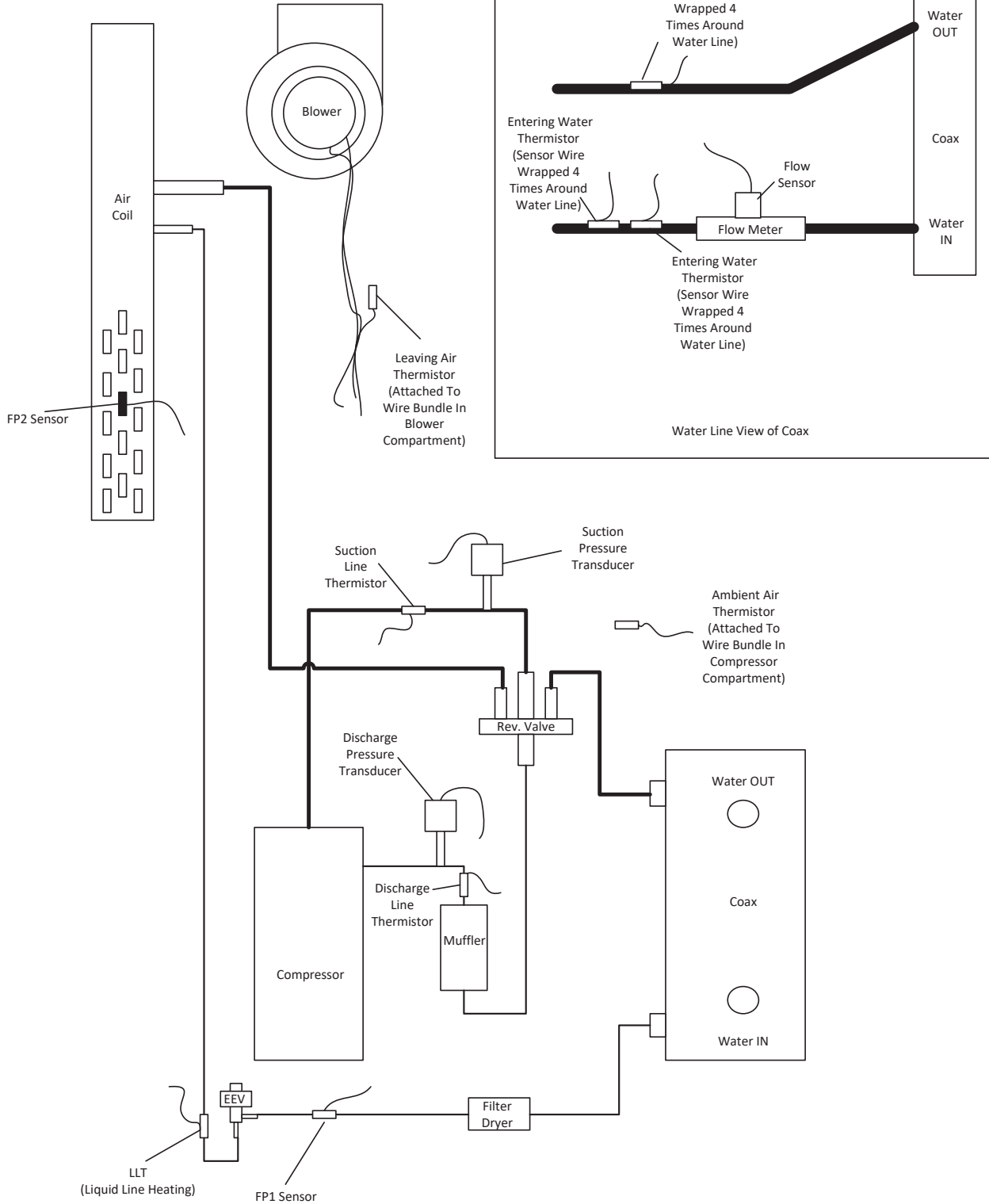

Troubleshooting

Startup/Troubleshooting Form

Dealer: _____ Controls Info: _____
 Phone #: _____ Date: _____ ABC Version: _____
 Problem: _____ AXB Version: _____
 Model #: _____ IZ2 Version: _____
 Serial #: _____ T-Stat Version: _____
 Installed Sensors: _____

COOLING CYCLE ANALYSIS

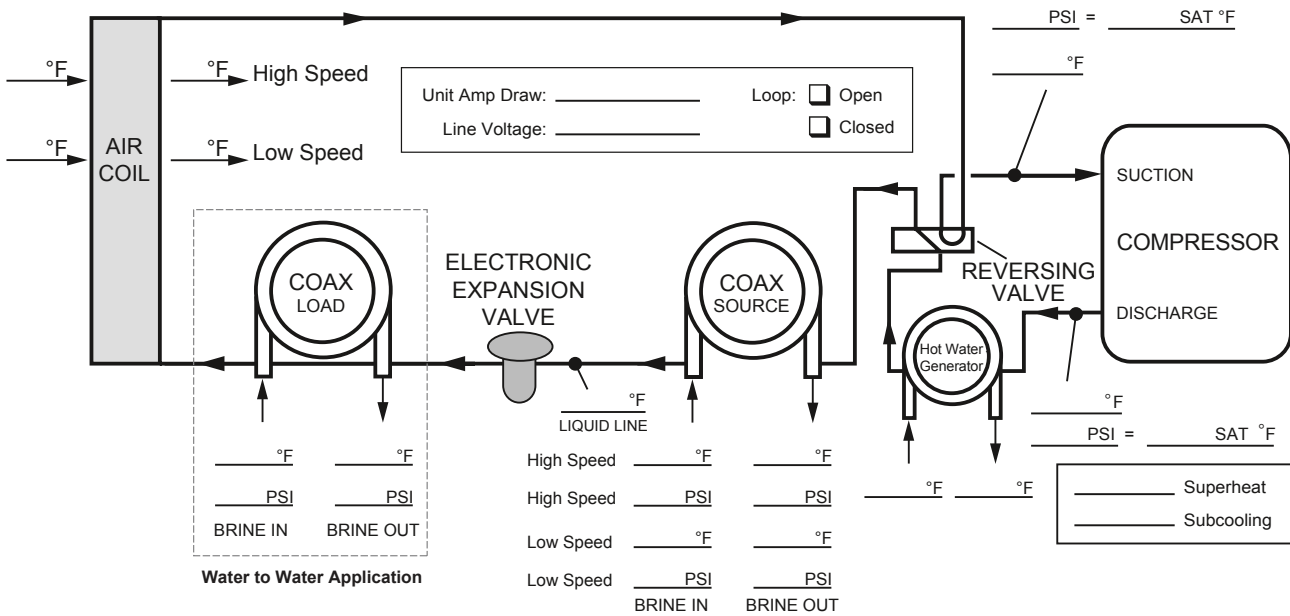

Heat of Extraction/Rejection = gpm x 500 (485 for water/antifreeze) x ΔT

Note: DO NOT hook up pressure gauges unless pressure sensors are suspect.

Note: Dehumidification must be deactivated for OptiDry to assess performance numbers accurately.

HEATING CYCLE ANALYSIS

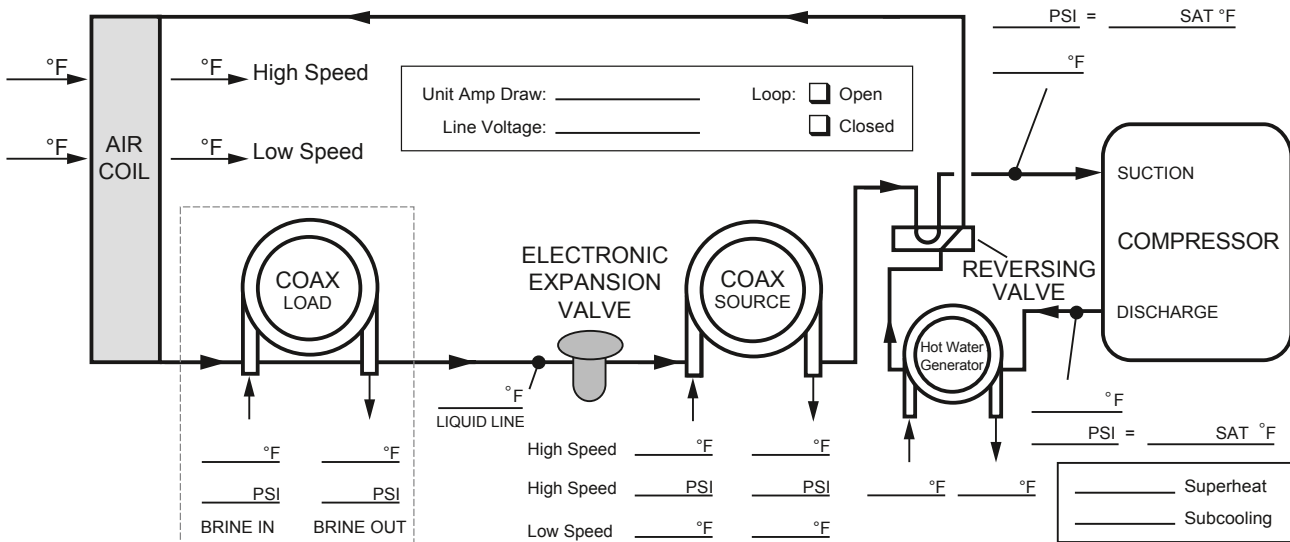

Troubleshooting

Variable Speed Startup/Troubleshooting Form

1. Job Information

Model # _____ Job Name: _____ Loop: Open / Closed
 Serial # _____ Install Date: _____ Hot Water Generator: Y / N

2. Flow Rate in gpm

SOURCE COAX

	HEATING SPEED 12	HEATING SPEED 4	COOLING SPEED 9	COOLING SPEED 3
WATER IN Pressure:	a. _____ psi	a. _____ psi	a. _____ psi	a. _____ psi
WATER OUT Pressure:	b. _____ psi	b. _____ psi	b. _____ psi	b. _____ psi
Pressure Drop: a - b	c. _____ psi	c. _____ psi	c. _____ psi	c. _____ psi
Look up flow rate in table:	d. _____ gpm	d. _____ gpm	d. _____ gpm	d. _____ gpm

3. Temperature Rise/Drop Across Coaxial Heat Exchanger¹

	HEATING SPEED 12	HEATING SPEED 4	COOLING SPEED 9	COOLING SPEED 3
WATER IN Temperature:	e. _____ °F	e. _____ °F	e. _____ °F	e. _____ °F
WATER OUT Temperature:	f. _____ °F	f. _____ °F	f. _____ °F	f. _____ °F
Temperature Difference:	g. _____ °F	g. _____ °F	g. _____ °F	g. _____ °F

4. Temperature Rise/Drop Across Air Coil

	HEATING SPEED 12	HEATING SPEED 4	COOLING SPEED 9	COOLING SPEED 3
SUPPLY AIR Temperature:	h. _____ °F	h. _____ °F	h. _____ °F	h. _____ °F
RETURN AIR Temperature:	i. _____ °F	i. _____ °F	i. _____ °F	i. _____ °F
Temperature Difference:	j. _____ °F	j. _____ °F	j. _____ °F	j. _____ °F

5. Heat of Rejection (HR)/Heat of Extraction (HE)

Brine Factor²: k. _____

	HEATING SPEED 12	HEATING SPEED 4	COOLING SPEED 9	COOLING SPEED 3
HR/HE = d x g x k	l. _____ Btu/h	l. _____ Btu/h	l. _____ Btu/h	l. _____ Btu/h

STEPS 6-9 NEED ONLY BE COMPLETED IF A PROBLEM IS SUSPECTED. USE HEATING SPEED 12 AND COOLING SPEED 9 FOR STEPS 6-9.

6. Watts

ENERGY MONITOR

	HEATING SPEED 12	COOLING SPEED 9
Volts:	m. _____ Volts	m. _____ Volts
Total Amps (Comp. + Blower) ³ :	n. _____ Amps	n. _____ Amps
Watts = m x n x 0.85:	o. _____ Watts	o. _____ Watts

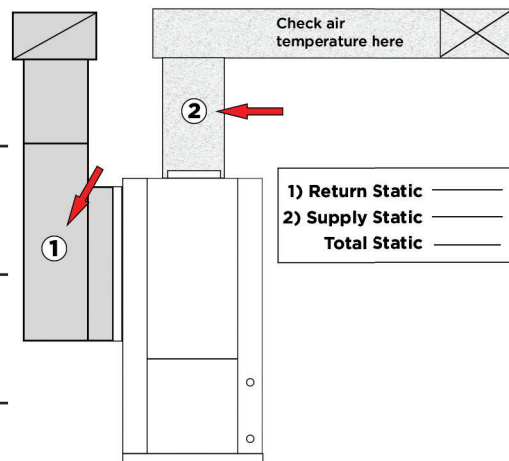

7. Capacity

	HEATING SPEED 12	COOLING SPEED 9
Cooling Capacity = l - (o x 3.413):	p. _____ Btu/h	p. _____ Btu/h
Heating Capacity = l + (o x 3.413):		

8. Efficiency

	HEATING SPEED 12	COOLING SPEED 9
Cooling EER = p / o:	q. _____ Btu/h	q. _____ Btu/h
Heating COP = p / (o x 3.413):		

9. Superheat (S.H.)/Subcooling (S.C.)

	HEATING SPEED 12	COOLING SPEED 9
Suction Pressure:	r. _____ psi	r. _____ psi
Suction Saturation Temperature:	s. _____ °F	s. _____ °F
Suction Line Temperature:	t. _____ °F	t. _____ °F
S.H. = t - s	u. _____ °F	u. _____ °F
Head Pressure:	v. _____ psi	v. _____ psi
High Pressure Saturation Temp:	w. _____ °F	w. _____ °F
Liquid Line Temperature ⁴ :	x. _____ °F	x. _____ °F
S.C. = w - x	y. _____ °F	y. _____ °F

Software Version	
ABC:	_____
AXB:	_____
IZ2:	_____
TSTAT:	_____

- NOTES:**
- Steps 3-9 should be conducted with the hot water generator disconnected.
 - Use 500 for pure water, 485 for methanol or Enviranol™. (This constant is derived by multiplying the weight of one gallon of water (8.34) times the minutes in one hour (60) times the specific heat of the fluid. Water has a specific heat of 1.0.)
 - If there is only one source of power for the compressor and blower, amp draw can be measured at the source wiring connection.
 - Liquid line is between the coax and the expansion device in the cooling mode; between the air coil and the expansion device in the heating mode.

Performance Data

024 - 50% Part Load

EWT °F	Flow gpm	WPD		HEATING - EAT 70°F							EWT °F	Flow gpm	WPD		COOLING - EAT 80/67 °F									
		PSI	FT	Airflow cfm	HC MBtuh	Power kW	HE MBtuh	LAT °F	COP	HWC MBtuh			PSI	FT	Airflow cfm	TC MBtuh	SC MBtuh	S/T Ratio	Power kW	HR MBtuh	EER	HWC MBtuh		
20	3.0	0.37	0.8	Operation not recommended							20	2.5	0.19	0.4	Operation not recommended									
	4.5	0.84	1.9	Operation not recommended								3.5	0.58	1.3	Operation not recommended									
	5.5	1.31	3.0	600	7.6	0.72	4.7	78.6	3.13	1.3		800	7.7	0.63	5.1	73.8	3.57	1.1						
30	3.0	0.35	0.8	600	8.0	0.60	5.5	79.4	3.92	1.4	30	2.5	0.18	0.4	500	13.7	10.0	0.73	0.40	14.2	34.5	-		
				800	8.3	0.61	5.8	74.9	3.97	1.2					650	14.0	11.0	0.79	0.41	14.5	33.8	-		
	4.5	0.81	1.9	600	8.2	0.60	5.7	79.9	4.00	1.5		3.5	0.56	1.3	500	13.9	10.1	0.73	0.38	14.3	36.8	-		
				800	8.5	0.61	6.0	75.3	4.06	1.3					650	14.1	11.0	0.78	0.40	14.6	35.5	-		
	5.5	1.27	2.9	600	9.0	0.72	6.1	81.9	3.69	1.6		5.0	0.94	2.2	500	14.0	10.1	0.72	0.37	14.3	38.1	-		
				800	9.1	0.63	6.5	76.2	4.21	1.3					650	14.3	11.0	0.77	0.39	14.7	37.2	-		
40	3.0	0.34	0.8	600	9.3	0.60	6.9	82.7	4.53	1.5	40	2.5	0.18	0.4	500	15.3	10.6	0.70	0.36	15.5	42.5	-		
				800	9.7	0.62	7.1	77.3	4.60	1.3					650	15.6	11.6	0.75	0.37	15.8	41.6	-		
	4.5	0.79	1.8	600	9.6	0.61	7.2	83.4	4.66	1.7		3.5	0.54	1.3	500	15.5	10.7	0.69	0.34	15.6	45.3	-		
				800	10.0	0.62	7.4	77.8	4.73	1.4					650	15.8	11.7	0.74	0.36	15.9	44.0	-		
	5.5	1.23	2.8	600	10.2	0.62	7.6	84.7	4.79	1.7		5.0	0.91	2.1	500	15.6	10.7	0.69	0.33	15.7	47.0	-		
				800	10.5	0.63	7.9	78.8	4.87	1.4					650	15.9	11.7	0.74	0.35	16.1	46.0	-		
50	3.0	0.33	0.8	600	10.7	0.61	8.2	86.0	5.12	1.7	50	2.5	0.17	0.4	500	16.6	10.9	0.65	0.31	16.6	53.2	-		
				800	11.0	0.62	8.5	79.7	5.21	1.4					650	17.1	12.0	0.70	0.32	17.1	53.6	-		
	4.5	0.76	1.8	600	11.1	0.61	8.6	86.9	5.29	1.8		3.5	0.53	1.2	500	16.8	10.9	0.65	0.30	16.7	55.1	-		
				800	11.4	0.62	8.9	80.4	5.39	1.5					650	17.3	12.1	0.70	0.31	17.2	55.6	-		
	5.5	1.19	2.8	600	11.6	0.63	9.0	88.2	5.42	1.9		5.0	0.88	2.0	500	17.1	11.2	0.66	0.30	17.0	56.5	-		
				800	11.9	0.64	9.3	81.3	5.51	1.7					650	17.6	12.4	0.71	0.31	17.4	57.0	-		
60	3.0	0.32	0.7	600	12.1	0.62	9.6	89.5	5.72	1.8	60	2.5	0.17	0.4	500	15.0	10.7	0.71	0.41	15.4	36.4	0.7		
				800	12.4	0.63	9.9	82.2	5.82	1.5					650	15.4	11.9	0.77	0.42	15.8	36.7	0.8		
	4.5	0.74	1.7	600	12.6	0.62	10.1	90.6	5.96	1.9		3.5	0.51	1.2	500	15.1	10.8	0.71	0.40	15.5	37.7	0.8		
				800	12.9	0.62	10.4	83.0	6.06	1.6					650	15.6	11.9	0.77	0.41	15.9	38.0	0.8		
	5.5	1.15	2.7	600	13.1	0.63	10.5	91.7	6.03	2.0		5.0	0.85	2.0	500	15.4	11.1	0.72	0.40	15.7	38.7	0.9		
				800	13.4	0.64	10.7	83.8	6.14	1.7					650	15.8	12.2	0.77	0.41	16.2	39.0	0.9		
70	3.0	0.31	0.7	600	13.5	0.63	11.0	92.9	6.30	1.9	70	2.5	0.16	0.4	500	13.4	10.6	0.79	0.51	14.2	26.1	0.9		
				800	13.7	0.64	11.1	84.5	6.34	1.6					650	14.0	11.9	0.85	0.60	15.1	23.2	1.0		
	4.5	0.71	1.7	600	14.1	0.63	11.6	94.3	6.60	2.0		3.5	0.49	1.1	500	13.5	10.6	0.79	0.50	14.3	27.1	1.1		
				800	14.4	0.63	11.8	85.7	6.73	1.7					650	13.9	11.8	0.85	0.51	14.7	27.3	1.1		
	5.5	1.12	2.6	600	14.5	0.64	11.9	95.2	6.63	2.1		5.0	0.83	1.9	500	13.7	10.9	0.80	0.49	14.5	27.7	1.1		
				800	14.8	0.64	12.1	86.3	6.76	1.8					650	13.7	11.9	0.87	0.44	15.3	31.1	1.1		
80	3.0	0.30	0.7	600	14.9	0.64	12.3	96.1	6.80	2.0	80	2.5	0.16	0.4	500	12.5	9.8	0.78	0.63	13.8	19.9	1.5		
				800	15.1	0.64	12.5	86.9	6.93	1.7					650	12.9	10.9	0.84	0.64	14.2	20.1	1.5		
	4.5	0.69	1.6	600	15.6	0.64	13.0	97.9	7.17	2.2		3.5	0.48	1.1	500	12.6	9.9	0.78	0.61	13.9	20.6	1.6		
				800	15.8	0.63	13.2	88.1	7.31	1.8					650	13.0	10.9	0.84	0.63	14.3	20.8	1.6		
	5.5	1.08	2.5	600	15.8	0.65	13.2	98.4	7.13	2.3		5.0	0.80	1.8	500	12.8	10.1	0.79	0.61	14.1	21.1	1.6		
				800	16.0	0.65	13.3	88.5	7.27	1.9					650	13.2	11.2	0.85	0.62	14.4	21.3	1.9		
90	3.0	0.29	0.7	600	16.2	0.65	13.6	99.4	7.28	2.2	90	2.5	0.15	0.3	500	11.7	9.0	0.77	0.75	13.4	15.6	1.9		
				800	16.4	0.65	13.7	89.2	7.43	1.8					650	12.0	10.0	0.83	0.76	13.8	15.8	1.9		
	4.5	0.67	1.5	600	17.1	0.65	14.4	101.4	7.72	2.3		3.5	0.46	1.1	500	11.8	9.1	0.77	0.73	13.5	16.2	2.0		
				800	17.2	0.64	14.6	90.6	7.88	1.9					650	12.1	10.1	0.83	0.74	13.8	16.3	2.0		
	5.5	1.04	2.4	600	17.1	0.66	14.4	101.6	7.61	2.5		5.0	0.78	1.8	500	12.5	9.6	0.77	0.74	14.2	16.9	2.1		
				800	17.2	0.65	14.6	90.7	7.76	2.0					650	11.8	10.9	0.92	0.74	14.6	15.9	2.1		
100	3.0	0.28	0.6	Operation not recommended							100	2.5	0.15	0.3	500	10.9	8.7	0.80	0.90	13.2	12.1	2.3		
	4.5	0.64	1.5	Operation not recommended								3.5	0.44	1.0	500	11.0	8.7	0.80	0.88	13.3	12.5	2.4		
	5.5	1.00	2.3	Operation not recommended								5.0	0.74	1.7	500	11.2	9.0	0.80	0.87	13.4	12.8	2.5		
110	3.0	0.27	0.6	Operation not recommended							110	2.5	0.14	0.3	500	10.1	8.3	0.83	1.06	13.0	9.5	2.2		
				650	10.4	9.2	0.89	1.08	13.4	9.6					2.3									
	4.5	0.62	1.4	Operation not recommended								3.5	0.43	1.0	500	10.2	8.4	0.82	1.03	13.0	9.9	2.4		
				650	10.5	9.3	0.89	1.05	13.4	10.0					2.4									
	5.5	0.96	2.2	Operation not recommended								5.0	0.71	1.6	500	10.4	8.6	0.83	1.02	13.2	10.1	2.6		
				650	10.7	9.5	0.89	1.04	13.5	10.2					2.6									
120	3.0	0.26	0.6	Operation not recommended							120	2.5	0.13	0.3	500	9.4	8.5	0.90	1.35	13.4	7.0	3.2		
				650	9.6	9.2	0.96	1.38	13.7	7.0					3.3									
	4.5	0.59	1.4	Operation not recommended								3.5	0.41	0.9	500	9.5	8.5	0.90	1.28	13.3	7.5	3.3		
				650	9.7	9.3	0.96	1.31	13.5	7.4					3.3									
	5.5	0.93	2.1	Operation not recommended								5.0	0.68	1.6	500	9.6	8.5	0.89	1.24	13.2	7.8	3.4		
				650	9.8	9.4	0.96	1.15	12.0	8.5					3.4									

Performance capacities shown in thousands of Btuh.

Performance Data

024 - 100% Full Load

EWT °F	Flow gpm	WPD		HEATING - EAT 70°F							EWT °F	Flow gpm	WPD		COOLING - EAT 80/67 °F							
		PSI	FT	Airflow cfm	HC MBtuh	Power kW	HE MBtuh	LAT °F	COP	HWC MBtuh			PSI	FT	Airflow cfm	TC MBtuh	SC MBtuh	S/T Ratio	Power kW	HR MBtuh	EER	HWC MBtuh
20	5.0	0.87	2.0	Operation not recommended							20	4.0	0.49	1.1	Operation not recommended							
	7.0	2.15	5.0	Operation not recommended								6.0	1.70	3.9	Operation not recommended							
	9.0	2.81	6.5	1000	22.4	2.11	14.2	90.7	3.12	3.8		1350	23.1	2.04	15.2	86.1	3.33	3.4				
30	5.0	0.85	2.0	1000	25.1	1.94	17.6	93.4	3.80	4.1	30	4.0	0.48	1.1	700	24.5	16.7	0.68	0.48	26.8	51.0	-
				1350	25.9	2.01	18.0	88.2	3.77	3.8					850	24.9	18.3	0.73	0.50	27.3	49.8	-
	7.0	2.09	4.8	1000	25.8	1.97	18.1	94.0	3.83	4.2		700	24.8	16.8	0.68	0.46	27.0	54.3	-			
				1350	26.5	2.03	18.6	88.6	3.83	3.9		850	25.2	18.4	0.73	0.48	27.5	52.4	-			
	9.0	2.36	5.5	1000	26.2	2.12	18.0	94.5	3.63	4.4		700	24.9	16.8	0.68	0.44	27.1	56.3	-			
				1350	25.2	1.90	18.8	89.3	3.89	5.0		850	25.6	18.4	0.72	0.47	27.8	54.9	-			
40	5.0	0.82	1.9	1000	29.0	1.97	21.3	97.2	4.31	4.5	40	4.0	0.46	1.1	700	25.9	18.0	0.70	0.58	28.6	45.0	-
				1350	29.9	2.02	22.0	91.2	4.33	4.0					850	26.4	19.7	0.75	0.60	29.3	44.0	-
	7.0	2.03	4.7	1000	30.0	2.01	22.1	98.1	4.36	4.6		700	26.2	18.2	0.69	0.55	28.8	47.9	-			
				1350	30.9	2.06	22.9	91.9	4.40	4.1		850	26.7	19.8	0.74	0.57	29.4	46.5	-			
	9.0	2.65	6.1	1000	30.5	2.03	22.6	98.7	4.41	4.8		700	26.4	18.2	0.69	0.53	28.9	49.7	-			
				1350	31.5	2.08	23.4	92.4	4.45	4.2		850	27.0	19.8	0.74	0.56	29.6	48.6	-			
50	5.0	0.79	1.8	1000	32.9	2.01	25.1	101.1	4.81	4.8	50	4.0	0.45	1.0	700	26.2	17.7	0.68	0.67	29.4	39.2	-
				1350	33.9	2.04	26.0	94.3	4.88	4.5					850	27.5	19.7	0.72	0.70	30.9	39.2	-
	7.0	1.97	4.5	1000	34.1	2.05	26.1	102.3	4.87	5.2		700	26.7	17.9	0.67	0.63	29.7	42.5	-			
				1350	35.2	2.08	27.1	95.2	4.96	4.6		850	28.1	19.9	0.71	0.66	31.3	42.6	-			
	9.0	2.56	5.9	1000	34.9	2.07	26.8	103.0	4.94	5.3		700	27.0	19.2	0.71	0.61	29.9	43.9	-			
				1350	36.0	2.10	27.8	95.8	5.02	5.4		850	28.3	20.8	0.73	0.60	30.5	47.2	-			
60	5.0	0.74	1.7	1000	36.2	2.02	28.3	104.3	5.24	4.9	60	4.0	0.45	1.0	700	25.1	17.8	0.71	0.92	28.8	27.3	1.3
				1350	37.3	2.04	29.4	96.8	5.38	4.5					850	26.4	19.8	0.75	0.96	30.2	27.4	1.4
	7.0	1.90	4.4	1000	37.8	2.08	29.7	105.9	5.33	5.4		700	25.7	18.0	0.70	0.87	29.2	29.4	1.4			
				1350	39.0	2.09	30.9	98.1	5.47	4.6		850	27.0	20.0	0.74	0.91	30.6	29.6	1.5			
	9.0	2.48	5.7	1000	38.7	2.10	30.5	106.8	5.40	5.5		700	26.0	19.0	0.73	0.85	29.4	30.5	1.4			
				1350	40.0	2.11	31.8	98.8	5.55	4.8		850	27.3	21.1	0.77	0.89	30.8	30.6	1.5			
70	5.0	0.72	1.7	1000	39.5	2.04	31.5	107.5	5.68	5.3	70	4.0	0.44	1.0	700	24.1	17.9	0.74	1.15	28.7	20.9	1.9
				1350	40.8	2.11	32.6	99.5	5.66	5.0					850	25.6	20.7	0.81	1.15	30.1	22.3	2.0
	7.0	1.84	4.3	1000	41.5	2.10	33.3	109.5	5.78	5.5		700	24.7	18.1	0.73	0.99	28.7	24.9	2.2			
				1350	42.8	2.10	34.6	101.0	5.97	5.1		850	25.8	20.1	0.78	1.03	29.9	25.1	2.2			
	9.0	1.94	4.5	1000	42.5	2.13	34.2	110.6	5.86	6.1		700	25.0	18.8	0.75	0.97	28.8	25.8	2.2			
				1350	42.0	2.12	34.7	100.4	5.81	6.6		850	26.3	19.8	0.75	0.98	28.9	26.8	2.3			
80	5.0	0.70	1.6	1000	42.2	2.07	34.1	110.2	5.96	5.8	80	4.0	0.43	1.0	700	23.0	17.7	0.77	1.40	27.8	16.5	2.8
				1350	43.7	2.06	35.6	101.6	6.22	4.9					850	23.9	19.7	0.82	1.44	28.9	16.6	2.8
	7.0	1.78	4.1	1000	44.6	2.16	36.2	112.6	6.06	6.0		700	23.6	17.9	0.76	1.35	28.3	17.5	2.9			
				1350	46.1	2.14	37.8	103.5	6.33	5.1		850	24.6	19.9	0.81	1.39	29.3	17.7	2.9			
	9.0	2.32	5.4	1000	45.9	2.19	37.4	113.9	6.16	6.1		700	23.9	18.4	0.77	1.32	28.4	18.1	3.1			
				1350	47.5	2.15	39.1	104.5	6.46	5.7		850	24.9	20.4	0.82	1.36	29.5	18.3	3.1			
90	5.0	0.67	1.6	1000	44.9	2.11	36.7	112.9	6.23	5.9	90	4.0	0.42	1.0	700	21.9	17.6	0.80	1.59	27.3	13.8	3.7
				1350	46.5	2.08	38.4	103.8	6.55	5.4					850	22.7	19.5	0.86	1.62	28.2	14.0	3.7
	7.0	1.71	4.0	1000	47.8	2.21	39.1	115.7	6.34	6.2		700	22.6	17.8	0.79	1.54	27.8	14.6	3.9			
				1350	49.5	2.17	41.0	106.0	6.68	5.7		850	23.4	19.7	0.84	1.58	28.8	14.8	3.9			
	9.0	1.79	4.1	1000	49.3	2.24	40.5	117.2	6.45	6.9		700	23.0	17.4	0.76	1.52	28.1	15.1	4.1			
				1350	51.4	2.29	43.6	109.9	6.58	7.9		850	23.9	18.9	0.79	1.47	27.6	16.3	3.9			
100	5.0	0.64	1.5	Operation not recommended							100	4.0	0.42	1.0	700	20.4	16.9	0.83	1.84	26.6	11.1	4.7
	7.0	1.65	3.8	Operation not recommended								6.0	1.03	2.4	700	21.1	17.1	0.81	1.80	27.2	11.7	5.0
	9.0	2.16	5.0	Operation not recommended								8.0	1.70	3.9	700	21.3	17.1	0.80	1.77	27.3	12.0	5.2
110	5.0	0.62	1.4	Operation not recommended							110	4.0	0.40	0.9	700	21.5	16.3	0.76	2.09	26.0	10.3	5.7
	7.0	1.59	3.7	Operation not recommended								6.0	0.99	2.3	700	22.4	16.5	0.74	2.07	26.6	10.8	5.9
	9.0	2.07	4.8	Operation not recommended								8.0	1.64	3.8	700	22.6	16.2	0.72	2.03	26.7	11.1	6.2
120	5.0	0.58	1.3	Operation not recommended							120	4.0	0.39	0.9	700	19.1	15.9	0.83	2.48	25.2	7.7	6.9
	7.0	1.53	3.5	Operation not recommended								6.0	0.95	2.2	700	19.5	17.4	0.89	2.54	25.7	7.7	7.1
	9.0	1.99	4.6	Operation not recommended								7.0	1.93	6.1	0.83	2.34	24.9	8.3	7.2			
				8.0	1.56	3.6	700	19.7	17.4	0.89		2.40	25.4	8.2	7.4							
850	20.2	17.1	0.85	2.17	25.1	9.3	7.5															

Performance capacities shown in thousands of Btuh.

Performance Data

036 - 50% Part Load

EWT °F	Flow gpm	WPD		HEATING - EAT 70°F							EWT °F	Flow gpm	WPD		COOLING - EAT 80/67 °F									
		PSI	FT	Airflow cfm	HC MBtuh	Power kW	HE MBtuh	LAT °F	COP	HWC MBtuh			PSI	FT	Airflow cfm	TC MBtuh	SC MBtuh	S/T Ratio	Power kW	HR MBtuh	EER	HWC MBtuh		
20	3.0	0.30	0.7	Operation not recommended							20	2.5	0.15	0.4	Operation not recommended									
	4.5	0.70	1.6	Operation not recommended								3.5	0.46	1.1	Operation not recommended									
	5.5	1.09	2.5	550	12.7	1.36	7.8	91.4	2.74	2.2		750	12.8	1.20	8.5	85.8	3.13	1.8	Operation not recommended					
30	3.0	0.30	0.7	550	13.3	1.13	9.2	92.3	3.44	2.3	30	2.5	0.15	0.3	500	18.3	12.5	0.68	0.57	20.2	32.2	-		
				750	13.8	1.16	9.7	87.1	3.49	2.0					650	18.6	13.7	0.74	0.59	20.7	31.5	-		
	4.5	0.68	1.6	550	13.6	1.14	9.5	92.9	3.51	2.6		500	18.5	12.6	0.68	0.54	20.4	34.3	-					
				750	14.2	1.17	10.0	87.5	3.56	2.2		650	18.8	13.8	0.73	0.57	20.8	33.1	-					
	5.5	1.06	2.4	550	15.0	1.36	10.1	95.3	3.24	2.7		500	18.6	12.6	0.68	0.52	20.4	35.6	-					
				750	15.1	1.09	10.8	88.6	4.05	2.2		650	19.1	13.8	0.72	0.55	21.0	34.7	-					
40	3.0	0.29	0.7	550	15.6	1.15	11.4	96.2	3.97	2.5	40	2.5	0.14	0.3	500	20.4	13.3	0.65	0.51	22.1	39.7	-		
				750	16.1	1.17	11.9	89.9	4.03	2.2					650	20.8	14.5	0.70	0.53	22.6	38.9	-		
	4.5	0.66	1.5	550	16.1	1.15	11.9	97.0	4.09	2.8		500	20.6	13.4	0.65	0.49	22.3	42.3	-					
				750	16.6	1.17	12.4	90.5	4.15	2.3		650	21.0	14.7	0.70	0.51	22.8	41.1	-					
	5.5	1.02	2.4	550	16.9	1.18	12.7	98.5	4.20	2.8		500	20.8	13.4	0.65	0.47	22.4	43.9	-					
				750	17.5	1.20	13.2	91.6	4.27	2.4		650	21.3	14.7	0.69	0.50	22.9	42.9	-					
50	3.0	0.28	0.6	550	17.8	1.16	13.7	100.0	4.49	2.8	50	2.5	0.14	0.3	500	22.2	13.6	0.61	0.45	23.7	49.7	-		
				750	18.4	1.18	14.2	92.7	4.57	2.3					650	22.8	15.0	0.66	0.46	24.4	50.1	-		
	4.5	0.64	1.5	550	18.5	1.17	14.3	101.1	4.64	3.0		500	22.4	13.7	0.61	0.44	23.9	51.4	-					
				750	19.0	1.18	14.8	93.5	4.73	2.5		650	23.0	15.1	0.66	0.44	24.5	51.9	-					
	5.5	0.99	2.3	550	19.3	1.19	15.0	102.5	4.75	3.1		500	22.8	14.0	0.62	0.43	24.2	52.7	-					
				750	19.9	1.21	15.6	94.6	4.83	2.8		650	23.4	15.5	0.66	0.44	24.9	53.2	-					
60	3.0	0.27	0.6	550	20.2	1.18	16.0	104.0	5.02	3.0	60	2.5	0.13	0.3	500	20.0	13.4	0.67	0.59	22.0	34.0	1.0		
				750	20.7	1.19	16.4	95.6	5.10	2.5					650	20.6	14.8	0.72	0.60	22.6	34.3	1.0		
	4.5	0.62	1.4	550	21.0	1.18	16.8	105.4	5.23	3.2		500	20.2	13.5	0.67	0.57	22.2	35.2	1.1					
				750	21.5	1.19	17.3	96.6	5.32	2.7		650	20.8	14.9	0.72	0.59	22.8	35.5	1.1					
	5.5	0.96	2.2	550	21.8	1.21	17.4	106.6	5.29	3.3		500	20.5	13.8	0.67	0.57	22.5	36.1	1.2					
				750	22.3	1.21	17.9	97.5	5.38	2.8		650	21.1	15.3	0.73	0.58	23.1	36.4	1.2					
70	3.0	0.26	0.6	550	22.6	1.20	18.3	108.0	5.53	3.2	70	2.5	0.13	0.3	500	17.8	13.2	0.74	0.73	20.3	24.4	1.3		
				750	22.9	1.21	18.6	98.3	5.56	2.6					650	18.6	14.9	0.80	0.86	21.5	21.6	1.3		
	4.5	0.60	1.4	550	23.6	1.19	19.3	109.7	5.79	3.4		500	18.0	13.3	0.74	0.71	20.4	25.3	1.4					
				750	24.0	1.19	19.7	99.6	5.90	2.9		650	18.5	14.7	0.80	0.73	21.0	25.5	1.4					
	5.5	0.93	2.1	550	24.2	1.22	19.8	110.7	5.82	3.5		500	18.3	13.6	0.75	0.71	20.7	25.9	1.5					
				750	24.6	1.12	20.2	100.4	6.43	2.9		650	18.8	15.1	0.80	0.72	21.3	26.1	1.5					
80	3.0	0.25	0.6	550	24.8	1.22	20.4	111.8	5.97	3.4	80	2.5	0.13	0.3	500	16.7	12.3	0.73	0.90	19.8	18.6	1.9		
				750	25.2	1.21	20.8	101.1	6.08	2.8					650	17.2	13.6	0.79	0.92	20.3	18.7	2.0		
	4.5	0.57	1.3	550	26.0	1.21	21.7	113.8	6.29	3.6		500	16.8	12.3	0.73	0.88	19.8	19.2	2.1					
				750	26.3	1.20	22.0	102.5	6.42	3.0		650	17.3	13.7	0.79	0.89	20.4	19.4	2.1					
	5.5	0.90	2.1	550	26.4	1.24	21.9	114.4	6.25	3.8		500	17.1	12.6	0.74	0.87	20.1	19.7	2.2					
				750	26.7	1.23	22.2	102.9	6.37	3.2		650	17.6	14.0	0.80	0.89	20.6	19.9	2.5					
90	3.0	0.24	0.6	550	27.1	1.24	22.6	115.5	6.39	3.6	90	2.5	0.12	0.3	500	15.6	11.3	0.73	1.07	19.2	14.6	2.6		
				750	27.3	1.23	22.9	103.7	6.52	2.9					650	16.0	12.5	0.78	1.09	19.7	14.7	2.6		
	4.5	0.55	1.3	550	28.4	1.23	24.0	117.9	6.78	3.8		500	15.7	11.4	0.72	1.04	19.2	15.1	2.7					
				750	28.6	1.21	24.3	105.3	6.92	3.2		650	16.1	12.6	0.78	1.06	19.7	15.2	2.7					
	5.5	0.87	2.0	550	28.6	1.25	24.1	118.1	6.67	4.1		500	16.7	12.0	0.72	1.06	20.3	15.8	2.8					
				750	28.7	1.14	24.3	105.4	7.38	3.4		650	16.4	12.9	0.79	1.05	20.0	15.6	2.8					
100	3.0	0.23	0.5	Operation not recommended							100	2.5	0.12	0.3	500	14.5	10.9	0.75	1.29	18.9	11.2	3.1		
	4.5	0.53	1.2	Operation not recommended								3.5	0.35	0.8	500	14.6	10.9	0.75	1.26	18.9	11.7	3.2		
	5.5	0.84	1.9	Operation not recommended								5.0	0.59	1.4	500	14.9	11.2	0.75	1.25	19.1	11.9	3.3		
110	3.0	0.22	0.5	Operation not recommended							110	2.5	0.11	0.3	500	13.5	10.4	0.77	1.51	18.6	8.9	3.0		
				650	13.8	11.5	0.83	1.54	19.1	9.0					3.0									
	4.5	0.51	1.2	Operation not recommended								3.5	0.34	0.8	500	13.6	10.5	0.77	1.47	18.6	9.2	3.3		
				650	14.0	11.6	0.83	1.50	19.1	9.3		3.2												
	5.5	0.80	1.9	Operation not recommended								5.0	0.57	1.3	500	13.8	10.8	0.78	1.46	18.8	9.5	3.4		
				650	14.2	11.9	0.84	1.49	19.3	9.5		3.4												
120	3.0	0.22	0.5	Operation not recommended							120	2.5	0.11	0.2	500	12.6	10.6	0.84	1.93	19.1	6.5	4.3		
				650	12.8	11.6	0.90	1.97	19.6	6.5					4.4									
	4.5	0.49	1.1	Operation not recommended								3.5	0.33	0.8	500	12.7	10.7	0.84	1.82	18.9	7.0	4.4		
				650	12.9	11.6	0.90	1.87	19.3	6.9		4.4												
	5.5	0.77	1.8	Operation not recommended								5.0	0.55	1.3	500	12.8	10.7	0.83	1.76	18.8	7.3	4.6		
				650	13.1	11.6	0.89	1.82	19.3	7.2		4.6												

Performance capacities shown in thousands of Btu/h.

Performance Data

036 - 100% Full Load

EWT °F	Flow gpm	WPD		HEATING - EAT 70°F							EWT °F	Flow gpm	WPD		COOLING - EAT 80/67 °F							
		PSI	FT	Airflow cfm	HC MBtuh	Power kW	HE MBtuh	LAT °F	COP	HWC MBtuh			PSI	FT	Airflow cfm	TC MBtuh	SC MBtuh	S/T Ratio	Power kW	HR MBtuh	EER	HWC MBtuh
20	5.5	1.09	2.5	Operation not recommended							20	4.5	0.70	1.6	Operation not recommended							
	8.0	2.69	6.2	Operation not recommended								7.0	1.70	3.9	Operation not recommended							
	11.5	3.51	8.1	1150	28.0	2.86	17.8	92.6	2.88	4.7		1500	28.9	2.76	19.0	87.8	3.06	4.3				
30	5.5	1.06	2.5	1150	31.4	2.63	21.9	95.3	3.50	5.2	30	4.5	0.68	1.6	1000	35.7	24.3	0.68	0.99	38.6	36.1	-
				1500	32.3	2.73	22.5	90.0	3.47	4.8					1300	36.3	26.7	0.73	1.03	39.4	35.3	-
	8.0	2.61	6.0	1150	32.2	2.67	22.6	95.9	3.53	5.3		7.0	1.65	3.8	1000	36.2	24.5	0.68	0.94	38.9	38.4	-
				1500	33.1	2.76	23.2	90.5	3.52	4.8		1300	36.7	26.8	0.73	0.99	39.7	37.1	-			
	11.5	3.41	7.9	1150	32.8	2.88	22.5	96.4	3.34	5.4		9.0	2.73	6.3	1000	36.3	24.5	0.68	0.91	39.0	39.8	-
				1500	33.8	2.48	23.8	90.9	4.00	5.0		1300	37.2	26.8	0.72	0.96	40.1	38.9	-			
40	5.5	1.02	2.4	1150	36.3	2.68	26.7	99.2	3.97	5.6	40	4.5	0.66	1.5	1000	37.7	26.2	0.70	1.19	41.3	31.8	-
				1500	37.4	2.74	27.5	93.1	3.99	5.0					1300	38.5	28.7	0.75	1.24	42.2	31.1	-
	8.0	2.53	5.9	1150	37.4	2.73	27.6	100.1	4.02	5.8		7.0	1.60	3.7	1000	38.2	26.5	0.69	1.13	41.6	33.9	-
				1500	38.6	2.79	28.6	93.8	4.05	5.1		1300	38.9	28.9	0.74	1.18	42.5	32.9	-			
	11.5	3.31	7.6	1150	38.2	2.76	28.3	100.7	4.06	5.9		9.0	2.65	6.1	1000	38.5	26.5	0.69	1.09	41.7	35.2	-
				1500	39.4	2.82	29.3	94.3	4.10	5.2		1300	39.3	28.9	0.74	1.14	42.8	34.4	-			
50	5.5	0.99	2.3	1150	41.2	2.73	31.4	103.1	4.43	6.0	50	4.5	0.64	1.5	1000	38.1	25.8	0.68	1.38	42.4	27.7	-
				1500	42.4	2.76	32.5	96.2	4.50	5.6					1300	40.1	28.7	0.72	1.45	44.6	27.7	-
	8.0	2.46	5.7	1150	42.7	2.79	32.7	104.4	4.49	6.5		7.0	1.55	3.6	1000	39.0	26.2	0.67	1.30	42.9	30.0	-
				1500	44.0	2.83	33.9	97.2	4.57	5.7		1300	41.0	29.0	0.71	1.36	45.1	30.1	-			
	11.5	3.20	7.4	1150	43.6	2.81	33.5	105.1	4.55	6.6		9.0	2.56	5.9	1000	39.3	27.9	0.71	1.27	43.2	31.1	-
				1500	45.0	2.85	34.8	97.8	4.63	6.8		1300	41.5	32.2	0.78	1.32	45.0	31.4	-			
60	5.5	0.93	2.2	1150	45.2	2.74	35.4	106.4	4.83	6.1	60	4.5	0.62	1.4	1000	36.6	26.0	0.71	1.58	41.6	23.2	1.9
				1500	46.7	2.76	36.8	98.8	4.95	5.7					1300	38.4	28.9	0.75	1.65	43.6	23.3	2.0
	8.0	2.38	5.5	1150	47.3	2.82	37.1	108.0	4.91	6.7		7.0	1.50	3.5	1000	37.5	26.3	0.70	1.50	42.2	25.0	2.1
				1500	48.8	2.84	38.6	100.1	5.03	5.8		1300	39.3	29.1	0.74	1.56	44.1	25.1	2.1			
	11.5	3.10	7.2	1150	48.4	2.85	38.2	109.0	4.97	6.9		9.0	2.48	5.7	1000	37.9	27.7	0.73	1.46	42.4	25.9	2.0
				1500	50.0	2.86	39.7	100.9	5.12	6.0		1300	39.7	30.7	0.77	1.53	44.5	26.0	2.2			
70	5.5	0.90	2.1	1150	49.3	2.76	39.4	109.7	5.23	6.6	70	4.5	0.60	1.4	1000	35.1	26.1	0.74	1.98	41.4	17.8	2.7
				1500	51.0	2.87	40.7	101.5	5.21	6.2					1300	37.2	30.1	0.81	1.97	43.4	18.9	2.9
	8.0	2.30	5.3	1150	51.9	2.86	41.6	111.8	5.32	6.9		7.0	1.45	3.4	1000	36.0	26.4	0.73	1.70	41.4	21.1	3.1
				1500	53.5	2.86	43.3	103.1	5.50	6.4		1300	37.6	29.2	0.78	1.76	43.1	21.3	3.1			
	11.5	3.00	6.9	1150	53.2	2.89	42.8	112.8	5.39	7.6		9.0	2.40	5.5	1000	36.4	27.4	0.75	1.66	41.6	21.9	3.2
				1500	55.0	2.88	44.7	104.0	5.60	6.6		1300	37.3	29.8	0.80	1.68	43.0	22.2	3.3			
80	5.5	0.87	0.1	1150	52.7	2.82	42.6	112.5	5.49	7.2	80	4.5	0.57	1.3	1000	33.5	25.8	0.77	2.06	40.1	16.3	4.0
				1500	54.6	2.79	44.5	103.7	5.73	6.1					1300	34.9	28.7	0.82	2.12	41.6	16.4	4.0
	8.0	2.22	5.1	1150	55.8	2.93	45.3	114.9	5.59	7.5		7.0	1.40	3.2	1000	34.5	26.1	0.76	1.99	40.8	17.4	4.2
				1500	57.7	2.90	47.3	105.6	5.83	6.3		1300	35.8	29.0	0.81	2.04	42.3	17.5	4.2			
	11.5	2.90	6.7	1150	57.4	2.97	46.7	116.2	5.67	7.7		9.0	2.32	5.4	1000	34.8	26.8	0.77	1.94	41.0	17.9	4.4
				1500	59.4	2.92	48.9	106.6	5.95	7.2		1300	36.3	29.7	0.82	2.00	42.6	18.1	4.4			
90	5.5	0.84	1.9	1150	56.2	2.87	45.9	115.2	5.74	7.4	90	4.5	0.55	1.3	1000	31.9	25.6	0.80	2.33	39.4	13.7	5.3
				1500	58.2	2.82	48.0	105.9	6.04	6.7					1300	33.1	28.4	0.86	2.39	40.7	13.8	5.3
	8.0	2.14	5.0	1150	59.7	3.00	48.9	118.1	5.84	7.8		7.0	1.35	3.1	1000	32.9	25.9	0.79	2.27	40.1	14.5	5.6
				1500	61.8	2.94	51.2	108.2	6.16	7.2		1300	34.1	28.8	0.84	2.32	41.5	14.7	5.6			
	11.5	2.79	6.5	1150	61.6	3.04	50.7	119.6	5.94	8.6		9.0	2.24	5.2	1000	33.5	25.4	0.76	2.24	40.6	15.0	5.9
				1500	63.7	3.02	53.1	109.3	6.18	7.9		1300	34.5	29.0	0.84	2.28	41.8	15.1	5.6			
100	5.5	0.80	1.8	Operation not recommended							100	4.5	0.53	1.2	1000	29.7	24.7	0.83	2.70	38.4	11.0	6.8
	8.0	2.07	4.8	Operation not recommended								7.0	1.30	3.0	1000	30.7	25.0	0.81	2.65	39.3	11.6	7.1
	11.5	2.69	6.2	Operation not recommended								9.0	2.16	5.0	1000	31.0	24.9	0.80	2.61	39.4	11.9	7.5
110	5.5	0.77	1.8	Operation not recommended							110	4.5	0.51	1.2	1000	27.4	23.8	0.87	3.07	37.4	8.9	8.1
				1300	28.2	26.3	0.93	3.11	38.3	9.1					8.0							
	8.0	1.99	4.6	Operation not recommended								7.0	1.25	2.9	1000	28.5	24.0	0.84	3.04	38.4	9.4	8.5
				1300	29.3	26.6	0.91	3.06	39.2	9.6		8.5										
	11.5	2.59	6.0	Operation not recommended								9.0	2.07	4.8	1000	28.8	23.7	0.82	2.99	38.5	9.6	8.9
				1300	29.6	26.1	0.88	3.02	39.4	9.8		8.1										
120	5.5	0.73	1.7	Operation not recommended							120	4.5	0.49	0.8	1000	24.4	23.2	0.95	3.65	36.3	6.7	9.9
				1300	24.9	25.3	1.02	3.73	37.1	6.7					10.2							
	8.0	1.91	4.4	Operation not recommended								7.0	1.20	2.8	1000	24.7	23.4	0.95	3.45	35.9	7.2	10.3
				1300	25.1	25.4	1.01	3.54	36.7	7.1		10.5										
	11.5	2.49	5.8	Operation not recommended								9.0	1.99	4.6	1000	24.9	23.4	0.94	3.34	35.8	7.5	10.7
				1300	25.4	25.4	1.00	3.44	36.7	7.4		10.7										

Performance capacities shown in thousands of Btuh.

Performance Data

048 - 50% Part Load

EWT °F	Flow gpm	WPD		HEATING - EAT 70°F							EWT °F	Flow gpm	WPD		COOLING - EAT 80/67 °F							
		PSI	FT	Airflow cfm	HC mBtuh	Power kW	HE MBtuh	LAT °F	COP	HWC MBtuh			PSI	FT	Airflow cfm	TC MBtuh	SC MBtuh	S/T Ratio	Power kW	HR MBtuh	EER	HWC MBtuh
20	3.5	0.56	1.3	Operation not recommended							20	3.0	0.47	1.1	Operation not recommended							
	5.0	0.97	2.2	Operation not recommended								4.5	0.81	1.9	Operation not recommended							
	6.5	1.37	3.2	650	16.5	1.72	10.7	95.4	2.82	2.4		900	16.9	1.55	11.7	89.1	3.19	3.1				
30	3.5	0.55	1.3	650	16.7	1.48	11.8	95.7	3.32	2.7	30	3.0	0.45	1.1	500	22.7	13.7	0.61	0.54	24.8	42.0	-
				900	17.3	1.50	12.3	89.6	3.38	2.4					750	23.1	15.1	0.65	0.56	25.3	41.1	-
				650	18.1	1.55	13.0	97.7	3.43	3.0					500	23.0	13.8	0.60	0.51	25.0	44.8	-
	5.0	0.94	2.2	900	18.6	1.56	13.5	91.0	3.51	2.6		750	23.3	15.1	0.65	0.54	25.5	43.2	-			
				650	18.8	1.75	13.0	98.7	3.15	3.1		500	23.1	13.8	0.60	0.50	25.1	46.4	-			
				900	19.2	1.34	14.7	91.3	4.19	2.6		750	23.7	15.1	0.64	0.52	25.7	45.3	-			
40	3.5	0.53	1.2	650	19.8	1.51	14.9	100.2	3.84	3.0	40	3.0	0.44	1.0	500	25.6	17.5	0.68	0.46	27.5	55.3	-
				900	20.5	1.52	15.5	92.9	3.94	2.6					750	26.1	19.2	0.73	0.48	28.0	54.1	-
				650	21.4	1.57	16.3	102.5	3.99	3.3					500	25.9	17.7	0.68	0.44	27.7	58.9	-
	5.0	0.91	2.1	900	22.1	1.57	17.1	94.6	4.13	2.8		750	26.4	19.3	0.73	0.46	28.3	57.2	-			
				650	22.1	1.58	17.0	103.5	4.09	3.4		500	26.1	17.7	0.68	0.43	27.9	61.2	-			
				900	22.9	1.59	17.7	95.4	4.20	2.8		750	26.7	19.3	0.72	0.45	28.5	59.8	-			
50	3.5	0.51	1.2	650	22.9	1.55	18.0	104.7	4.34	3.3	50	3.0	0.43	1.0	500	24.5	15.8	0.65	0.64	27.0	38.1	-
				900	23.7	1.55	18.8	96.2	4.48	2.8					750	25.3	18.6	0.74	0.67	27.8	37.7	-
				650	24.7	1.60	19.7	107.3	4.53	3.6					500	25.0	15.9	0.64	0.56	27.2	45.0	-
	5.0	0.88	2.0	900	25.7	1.59	20.7	98.3	4.74	3.0		750	25.8	18.7	0.73	0.58	28.1	44.2	-			
				650	25.7	1.61	20.6	108.7	4.68	3.8		500	25.2	15.9	0.63	0.52	27.2	48.0	-			
				900	26.5	1.61	21.5	99.2	4.83	3.3		750	21.3	17.0	0.80	0.41	24.3	52.1	-			
60	3.5	0.50	1.1	650	25.7	1.61	20.7	108.8	4.70	3.7	60	3.0	0.41	1.0	500	23.5	15.4	0.66	0.79	26.5	29.8	1.2
				900	26.7	1.60	21.7	99.4	4.90	3.0					750	24.2	18.2	0.75	0.82	27.3	29.5	1.2
				650	27.8	1.65	22.7	111.8	4.96	3.9					500	23.9	15.5	0.65	0.70	26.5	34.2	1.3
	5.0	0.85	2.0	900	28.9	1.63	23.9	101.7	5.21	3.3		750	24.6	18.3	0.74	0.73	27.4	33.6	1.3			
				650	29.0	1.66	23.9	113.6	5.12	4.1		500	24.2	15.6	0.65	0.66	26.7	36.4	1.4			
				900	30.1	1.64	25.1	102.9	5.37	3.5		750	24.9	18.3	0.74	0.69	27.5	35.9	1.4			
70	3.5	0.48	1.1	650	28.5	1.66	23.4	112.9	5.03	4.0	70	3.0	0.40	0.9	500	22.5	15.0	0.67	0.93	25.9	24.2	1.7
				900	31.1	1.66	26.1	104.0	5.48	3.3					750	23.4	17.8	0.76	0.98	27.0	23.9	1.8
				650	31.0	1.69	25.8	116.4	5.36	4.3					500	22.7	15.2	0.67	0.84	25.9	27.0	1.9
	5.0	0.83	1.9	900	32.2	1.66	27.2	105.2	5.67	3.6		750	23.5	17.9	0.76	0.88	26.7	26.7	1.9			
				650	32.4	1.71	27.2	118.5	5.54	4.5		500	23.1	15.3	0.66	0.80	26.2	28.7	1.9			
				900	33.6	1.71	28.1	108.9	5.76	3.7		750	23.8	17.9	0.75	0.84	27.0	28.5	2.0			
80	3.5	0.46	1.1	650	30.5	1.75	25.1	115.7	5.09	4.2	80	3.0	0.39	0.9	500	21.4	14.5	0.68	1.10	25.4	19.5	2.5
				900	31.6	1.72	26.4	104.6	5.38	3.5					750	22.1	17.1	0.77	1.15	26.3	19.3	2.5
				650	33.1	1.77	27.7	119.5	5.47	4.5					500	21.5	14.7	0.68	1.02	25.3	21.1	2.6
	5.0	0.80	1.8	900	34.4	1.73	29.3	107.5	5.83	3.8		750	22.2	17.3	0.78	1.06	26.1	20.9	2.7			
				650	34.8	1.79	29.4	121.9	5.68	4.8		500	22.0	14.8	0.67	0.98	25.6	22.6	2.8			
				900	36.2	1.74	31.0	109.3	6.08	4.0		750	22.7	17.4	0.77	1.02	26.4	22.3	3.2			
90	3.5	0.45	1.0	650	32.4	1.84	26.7	118.4	5.15	4.5	90	3.0	0.37	0.9	500	20.3	14.0	0.69	1.26	24.9	16.1	3.4
				900	33.6	1.80	28.2	106.7	5.47	3.7					750	21.0	16.5	0.79	1.31	25.7	16.0	3.4
				650	35.2	1.85	29.6	122.5	5.56	4.8					500	20.3	14.2	0.70	1.20	24.7	17.0	3.5
	5.0	0.77	1.8	900	36.7	1.79	31.4	109.9	5.99	4.0		750	20.9	16.7	0.80	1.24	25.4	16.9	3.6			
				650	37.1	1.87	31.6	125.4	5.81	5.2		500	19.5	13.4	0.69	1.21	23.8	16.1	3.7			
				900	38.7	1.69	36.4	112.5	6.70	4.3		750	20.1	16.9	0.84	1.27	26.1	15.8	3.7			
100	3.5	0.43	1.0	Operation not recommended							100	3.0	0.36	0.8	500	18.4	12.9	0.70	1.48	23.7	12.4	4.3
	5.0	0.74	1.7	Operation not recommended								4.5	0.62	1.4	750	18.9	15.1	0.80	1.54	24.4	12.3	4.3
	6.5	1.05	2.4	Operation not recommended								6.0	0.89	2.1	500	18.2	13.0	0.71	1.44	23.4	12.7	4.4
110	3.5	0.41	1.0	Operation not recommended							110	3.0	0.35	0.8	500	16.4	11.7	0.71	1.69	22.4	9.7	5.0
				750	16.8	13.7	0.82	1.76	23.1	9.6					5.0							
				500	16.1	11.8	0.73	1.68	22.1	9.6					5.4							
	5.0	0.71	1.6	Operation not recommended								4.5	0.60	1.4	750	16.7	13.9	0.84	1.75	22.9	9.5	5.4
				6.0	0.86	2.0	500	16.9	12.1	0.71		1.63	22.7	10.4	5.8							
				750	17.4	14.2	0.81	1.70	23.4	10.2		5.8										
120	3.5	0.40	0.9	Operation not recommended							120	3.0	0.33	0.8	500	15.2	12.4	0.82	2.10	22.6	7.2	6.4
				750	15.5	13.5	0.87	2.15	23.1	7.2					6.5							
				500	15.4	12.5	0.81	1.99	22.4	7.7					6.6							
	5.0	0.68	1.6	Operation not recommended								4.5	0.58	1.3	750	15.7	13.6	0.87	2.04	22.9	7.7	6.6
				6.0	0.82	1.9	500	15.5	12.5	0.81		1.92	22.3	8.1	6.8							
				750	15.9	14.8	0.94	1.98	23.0	8.0		6.8										

Performance capacities shown in thousands of Btuh.

Performance Data

048 - 100% Full Load

EWT °F	Flow gpm	WPD		HEATING - EAT 70°F							EWT °F	Flow gpm	WPD		COOLING - EAT 80/67 °F							
		PSI	FT	Airflow cfm	HC mBtuh	Power kW	HE MBtuh	LAT °F	COP	HWC MBtuh			PSI	FT	Airflow cfm	TC MBtuh	SC MBtuh	S/T Ratio	Power kW	HR MBtuh	EER	HWC MBtuh
20	6.5	1.40	3.2	Operation not recommended							20	5.5	1.05	2.4	Operation not recommended							
	10.0	2.85	6.6	Operation not recommended								8.0	2.00	4.6	Operation not recommended							
	13.5	4.79	11.1	1500	37.5	3.85	24.3	92.5	2.86	6.05		1800	37.7	3.77	24.8	88.6	2.93	5.6				
30	6.5	1.36	3.2	1500	37.9	3.65	25.4	92.7	3.04	6.6	30	5.5	1.02	2.4	1000	42.8	28.0	0.65	1.32	46.9	32.5	-
				1800	39.1	3.70	26.5	89.4	3.10	6.1					1400	43.6	30.8	0.70	1.37	47.9	31.8	-
				1500	40.9	3.81	27.9	94.6	3.14	6.8					1000	43.4	28.3	0.65	1.25	47.3	34.6	-
	10.0	2.77	6.4	1800	42.2	3.84	29.0	91.0	3.22	6.1	1400	44.1	30.9	0.70	1.32	48.2	33.4	-				
				1500	43.1	3.97	29.6	96.1	3.18	6.9	1000	43.6	28.3	0.65	1.22	47.4	35.9	-				
				1800	39.3	3.30	28.0	90.2	3.50	6.3	1400	44.7	30.9	0.69	1.28	48.7	35.0	-				
40	6.5	1.32	3.1	1500	43.2	3.80	30.2	96.1	3.33	7.0	40	5.5	0.99	2.3	1000	44.7	29.0	0.65	1.56	49.5	28.6	-
				1800	44.6	3.82	31.5	92.3	3.42	6.2					1400	45.5	31.7	0.70	1.63	50.6	28.0	-
				1500	46.6	3.94	33.1	98.3	3.46	7.3					1000	45.2	29.2	0.65	1.49	49.8	30.4	-
	10.0	2.69	6.2	1800	48.2	3.94	34.8	94.2	3.58	6.4	1400	46.0	31.9	0.69	1.56	50.9	29.6	-				
				1500	48.1	3.97	34.6	99.2	3.55	7.5	1000	45.5	29.2	0.64	1.44	50.0	31.6	-				
				1800	49.7	3.99	36.1	95.0	3.65	6.5	1400	46.6	31.9	0.69	1.51	51.2	30.9	-				
50	6.5	1.28	3.0	1500	48.5	3.94	35.0	99.5	3.61	7.5	50	5.5	0.96	2.2	1000	45.7	27.8	0.61	2.03	52.0	22.5	-
				1800	50.0	3.94	36.6	95.2	3.72	7.0					1400	47.1	32.8	0.70	2.11	53.7	22.3	-
				1500	52.3	4.07	38.4	101.9	3.77	8.2					1000	46.7	27.9	0.60	1.76	52.1	26.6	-
	10.0	2.60	6.0	1800	54.3	4.04	40.5	97.4	3.93	7.2	1400	48.1	32.9	0.68	1.84	53.8	26.1	-				
				1500	54.3	4.09	40.3	103.2	3.88	8.4	1000	47.0	27.9	0.59	1.65	52.1	28.4	-				
				1800	56.1	4.09	42.1	98.3	4.01	8.6	1400	48.4	32.9	0.68	1.73	53.8	28.0	-				
60	6.5	1.24	2.9	1500	54.2	4.10	40.2	103.1	3.87	7.6	60	5.5	0.93	2.2	1000	43.9	27.2	0.62	2.26	50.9	19.4	2.6
				1800	56.2	4.08	42.3	98.4	4.04	7.1					1400	45.2	32.1	0.71	2.36	52.6	19.1	2.8
				1500	58.7	4.20	44.3	106.0	4.09	8.4					1000	44.6	27.4	0.62	2.01	50.8	22.2	2.9
	10.0	2.52	5.8	1800	60.9	4.15	46.8	100.9	4.30	7.2	1400	45.9	32.3	0.70	2.10	52.5	21.9	2.9				
				1500	61.1	4.24	46.7	107.5	4.23	8.6	1000	45.1	27.5	0.61	1.91	51.0	23.6	2.8				
				1800	63.3	4.19	49.0	102.2	4.43	7.4	1400	46.5	32.4	0.70	1.99	52.6	23.3	3.0				
70	6.5	1.20	2.8	1500	60.0	4.26	45.4	106.8	4.13	8.1	70	5.5	0.90	2.1	1000	42.0	26.7	0.63	2.50	49.7	16.8	3.4
				1800	64.4	4.27	49.9	102.8	4.43	7.5					1400	43.7	31.7	0.73	2.50	51.4	17.5	3.7
				1500	65.1	4.33	50.3	110.0	4.40	8.6					1000	42.4	26.9	0.63	2.26	49.5	18.8	3.9
	10.0	2.44	5.6	1800	67.6	4.26	53.1	104.5	4.65	7.9	1400	43.8	31.7	0.72	2.36	51.1	18.5	3.9				
				1500	60.5	4.07	46.6	107.1	4.36	9.4	1000	43.2	27.1	0.63	2.16	49.9	20.0	3.9				
				1800	66.5	3.99	52.8	103.9	4.88	8.2	1400	44.5	31.8	0.71	2.24	51.5	19.8	4.1				
80	6.5	1.16	2.7	1500	64.9	4.47	49.7	109.9	4.25	9.0	80	5.5	0.87	2.0	1000	39.8	25.7	0.65	2.80	48.5	14.2	5.4
				1800	67.4	4.40	52.4	104.4	4.50	7.7					1400	41.0	30.2	0.74	2.92	50.1	14.1	5.4
				1500	70.5	4.52	55.1	113.5	4.57	9.5					1000	40.0	26.0	0.65	2.60	48.1	15.4	5.7
	10.0	2.35	5.4	1800	73.4	4.41	58.3	107.5	4.88	7.9	1400	41.2	30.6	0.74	2.70	49.6	15.2	5.7				
				1500	74.1	4.57	58.5	115.8	4.75	9.6	1000	40.9	26.2	0.64	2.49	48.6	16.4	5.9				
				1800	77.0	4.45	61.9	109.5	5.08	9.0	1400	42.2	30.8	0.73	2.59	50.2	16.3	5.9				
90	6.5	1.12	2.6	1500	69.9	4.68	53.9	113.1	4.37	9.7	90	5.5	0.84	1.9	1000	37.6	24.8	0.66	3.10	47.2	12.1	6.7
				1800	72.6	4.58	57.0	107.1	4.64	8.6					1400	38.8	29.1	0.75	3.22	48.7	12.0	6.6
				1500	76.0	4.71	59.9	117.0	4.73	9.5					1000	37.6	25.1	0.67	2.94	46.7	12.8	7.0
	10.0	2.27	5.2	1800	79.1	4.56	63.6	110.6	5.09	8.9	1400	38.6	29.5	0.76	3.04	48.0	12.7	7.0				
				1500	80.1	4.76	63.9	119.6	4.93	10.4	1000	37.3	24.9	0.67	2.85	46.1	13.1	7.3				
				1800	81.2	4.36	66.3	111.8	5.46	9.7	1400	39.8	29.8	0.75	3.00	48.9	13.3	7.4				
100	6.5	1.08	2.5	Operation not recommended							100	5.5	0.81	1.9	1000	35.1	23.9	0.68	3.45	45.8	10.2	8.9
	10.0	2.19	5.1	Operation not recommended								8.0	1.53	3.5	1400	36.2	28.1	0.78	3.59	47.3	10.1	8.8
	13.5	3.67	8.5	Operation not recommended								10.5	2.25	5.2	1000	34.9	24.2	0.69	3.36	45.3	10.4	9.3
110	6.5	1.04	2.4	Operation not recommended							110	5.5	0.78	1.8	1400	36.0	28.5	0.79	3.49	46.8	10.3	9.2
				1000	32.7	23.1	0.71	3.80	44.5	8.6					10.6							
				1400	33.6	27.0	0.80	3.95	45.9	8.5					10.5							
	10.0	2.11	4.9	Operation not recommended							110	8.0	1.47	3.4	1000	32.2	23.3	0.72	3.78	43.9	8.5	11.1
				1400	33.3	27.5	0.82	3.93	45.5	8.5					11.1							
				1000	33.8	23.8	0.70	3.66	45.1	9.2					11.6							
13.5	3.53	8.2	Operation not recommended							110	10.5	2.17	5.0	1400	34.7	27.9	0.80	3.82	46.5	9.1	10.5	
			1000	30.9	24.4	0.79	4.57	45.0	6.8					12.8								
			1400	31.5	26.6	0.84	4.68	46.0	6.7					13.1								
120	6.5	1.00	2.3	Operation not recommended							120	5.5	0.75	1.7	1000	31.3	24.6	0.79	4.32	44.7	7.2	13.2
				1400	31.8	26.7	0.84	4.43	45.6	7.2					13.6							
				1000	31.5	24.6	0.78	4.18	44.5	7.5					13.8							
10.0	2.02	4.7	Operation not recommended							120	8.0	1.42	3.3	1400	32.2	26.7	0.83	4.30	45.6	7.5	14.0	
			1000	30.9	24.4	0.79	4.57	45.0	6.8					12.8								
			1400	31.5	26.6	0.84	4.68	46.0	6.7					13.1								
13.5	3.39	7.8	Operation not recommended							120	10.5	2.08	4.8	1000	31.5	24.6	0.78	4.18	44.5	7.5	13.8	
			1400	32.2	26.7	0.83	4.30	45.6	7.5					14.0								
			1000	30.9	24.4	0.79	4.57	45.0	6.8					12.8								

Performance capacities shown in thousands of Btu/h.

Performance Data

060 - 50% Part Load

EWT °F	Flow gpm	WPD		HEATING - EAT 70°F							EWT °F	Flow gpm	WPD		COOLING - EAT 80/67 °F									
		PSI	FT	Airflow cfm	HC mBtuh	Power kW	HE MBtuh	LAT °F	COP	HWC MBtuh			PSI	FT	Airflow cfm	TC MBtuh	SC MBtuh	S/T Ratio	Power kW	HR MBtuh	EER	HWC MBtuh		
20	4.5	0.63	1.5	Operation not recommended							20	4.0	0.43	1.0	Operation not recommended									
	6.3	1.17	2.7	Operation not recommended								6.0	1.22	2.8	Operation not recommended									
	8.5	1.94	4.5	850	21.0	2.18	13.5	92.9	2.82	3.4		1100	21.4	2.02	14.5	88.0	3.10	3.1	700	29.9	17.4	0.58	0.73	32.8
30	4.5	0.61	1.4	850	23.8	2.01	16.9	95.9	3.47	3.9	30	4.0	0.42	1.0	700	30.5	19.1	0.63	0.76	33.4	40.3	-		
				1100	24.6	2.03	17.7	90.7	3.54	3.4					950	30.8	19.2	0.62	0.73	33.7	42.4	-		
	6.3	1.14	2.6	850	23.6	2.03	16.7	95.7	3.40	4.1	6.0	1.18	2.7	700	30.4	17.6	0.58	0.69	33.1	44.0	-			
				1100	24.5	2.06	17.4	90.6	3.48	3.5				950	30.8	19.2	0.62	0.73	33.7	42.4	-			
	8.5	1.89	4.4	850	24.8	2.22	17.2	97.0	3.27	4.2	7.5	1.75	4.0	700	30.5	17.6	0.58	0.67	33.1	45.6	-			
				1100	25.3	2.06	18.3	91.3	3.60	3.6				950	31.3	19.2	0.61	0.70	34.0	44.5	-			
40	4.5	0.60	1.4	850	27.5	2.05	20.5	100.0	3.94	4.3	40	4.0	0.41	0.9	700	30.9	19.9	0.64	0.77	33.9	39.9	-		
				1100	28.4	2.06	21.3	93.9	4.03	3.7					950	31.5	21.8	0.69	0.81	34.6	39.1	-		
	6.3	1.10	2.5	850	27.7	2.08	20.6	100.2	3.90	4.5	6.0	1.15	2.6	700	31.3	20.1	0.64	0.73	34.1	42.5	-			
				1100	28.5	2.09	21.4	94.0	4.00	3.8				950	31.8	21.9	0.69	0.77	34.8	41.3	-			
	8.5	1.83	4.2	850	28.6	2.09	21.5	101.2	4.02	4.7	7.5	1.70	3.9	700	31.5	20.1	0.64	0.71	34.3	44.2	-			
				1100	29.4	2.10	22.3	94.7	4.11	3.9				950	32.2	21.9	0.68	0.75	35.1	43.2	-			
50	4.5	0.58	1.3	850	31.3	2.09	24.2	104.1	4.39	4.7	50	4.0	0.40	0.9	700	32.0	21.5	0.67	0.80	35.1	40.3	-		
				1100	32.2	2.09	25.0	97.1	4.51	3.9					950	33.0	24.5	0.74	0.84	36.2	39.3	-		
	6.3	1.07	2.5	850	31.8	2.13	24.5	104.6	4.38	4.9	6.0	1.11	2.6	700	32.1	21.7	0.68	0.77	35.1	41.9	-			
				1100	32.5	2.12	25.3	97.4	4.50	4.1				950	33.1	24.6	0.75	0.80	36.2	41.2	-			
	8.5	1.77	4.1	850	32.8	2.14	25.5	105.7	4.48	5.2	7.5	1.64	3.8	700	32.2	21.7	0.67	0.75	35.2	42.8	-			
				1100	33.5	2.13	26.2	98.2	4.61	4.6				950	32.8	24.4	0.74	0.67	36.1	49.0	-			
60	4.5	0.56	1.3	850	35.3	2.13	28.0	108.5	4.86	5.1	60	4.0	0.38	0.9	700	31.1	21.2	0.68	0.98	34.8	31.8	1.5		
				1100	36.1	2.11	28.9	100.4	5.01	4.2					950	32.0	24.0	0.75	1.02	35.9	31.3	1.6		
	6.3	1.03	2.4	850	36.4	2.17	29.0	109.7	4.92	5.3	6.0	1.08	2.5	700	31.2	21.4	0.69	0.95	34.8	33.0	1.7			
				1100	37.0	2.14	29.7	101.1	5.07	4.5				950	32.2	24.2	0.75	0.99	35.9	32.5	1.7			
	8.5	1.72	4.0	850	37.3	2.19	29.8	110.6	5.00	5.6	7.5	1.59	3.7	700	31.4	21.5	0.68	0.93	34.9	33.9	1.8			
				1100	37.9	2.16	30.5	101.9	5.15	4.7				950	32.3	24.3	0.75	0.97	36.0	33.3	1.8			
70	4.5	0.54	1.2	850	39.3	2.17	31.9	112.8	5.31	5.4	70	4.0	0.37	0.9	700	30.1	20.9	0.70	1.16	34.4	26.0	2.1		
				1100	38.6	2.15	31.3	102.5	5.26	4.5					950	31.4	24.0	0.76	1.32	36.2	23.7	2.3		
	6.3	1.00	2.3	850	41.0	2.20	33.5	114.6	5.45	5.8	6.0	1.04	2.4	700	30.3	21.1	0.70	1.13	34.5	27.0	2.4			
				1100	41.4	2.16	34.1	104.9	5.63	4.8				950	31.3	23.8	0.76	1.17	35.6	26.6	2.4			
	8.5	1.66	3.8	850	41.8	2.23	34.1	115.5	5.49	6.0	7.5	1.54	3.6	700	30.5	21.2	0.70	1.10	34.6	27.7	2.5			
				1100	42.2	2.18	34.8	105.5	5.67	5.0				950	31.2	23.8	0.76	1.14	35.4	27.4	2.5			
80	4.5	0.52	1.2	850	42.9	2.23	35.3	116.7	5.64	5.8	80	4.0	0.36	0.8	700	28.4	20.5	0.72	1.38	33.4	20.6	3.1		
				1100	43.3	2.18	35.8	106.4	5.81	4.8					950	29.3	22.9	0.78	1.42	34.5	20.5	3.2		
	6.3	0.97	2.2	850	45.3	2.27	37.6	119.3	5.86	6.2	6.0	1.00	2.3	700	28.6	20.7	0.72	1.34	33.6	21.3	3.3			
				1100	45.5	2.20	38.0	108.3	6.06	5.1				950	29.5	23.2	0.79	1.39	34.6	21.2	3.4			
	8.5	1.60	3.7	850	45.8	2.30	38.0	119.9	5.85	6.6	7.5	1.49	3.4	700	28.8	20.9	0.72	1.32	33.7	21.8	3.5			
				1100	46.0	2.23	38.4	108.7	6.05	5.4				950	29.7	23.3	0.78	1.37	34.8	21.7	4.0			
90	4.5	0.50	1.2	850	46.5	2.29	38.6	120.6	5.94	6.2	90	4.0	0.34	0.8	700	26.6	20.1	0.75	1.60	32.4	16.7	4.4		
				1100	46.6	2.23	39.0	109.2	6.12	5.0					950	27.4	22.3	0.81	1.64	33.4	16.7	4.4		
	6.3	0.93	2.2	850	49.6	2.33	41.6	124.0	6.24	6.6	6.0	0.97	2.2	700	26.9	20.3	0.75	1.56	32.6	17.3	4.6			
				1100	49.6	2.24	41.9	111.7	6.48	5.4				950	27.7	22.6	0.82	1.61	33.6	17.2	4.6			
	8.5	1.55	3.6	850	49.9	2.36	41.8	124.4	6.19	7.1	7.5	1.43	3.3	700	26.8	18.8	0.70	1.59	32.5	16.9	4.8			
				1100	49.8	2.28	42.0	111.9	6.40	5.8				950	28.2	22.7	0.80	1.64	33.2	17.2	4.8			
100	4.5	0.48	1.1	Operation not recommended							100	4.0	0.33	0.8	700	24.8	19.5	0.79	1.92	31.7	12.9	5.4		
	6.3	0.90	2.1	Operation not recommended								6.0	0.93	2.2	950	25.6	21.6	0.84	1.97	32.6	13.0	5.4		
	8.5	1.49	3.4	Operation not recommended								7.5	1.38	3.2	700	25.1	19.7	0.79	1.89	31.9	13.3	5.5		
110	4.5	0.47	1.1	Operation not recommended							110	4.0	0.32	0.7	950	25.9	21.8	0.84	1.94	32.8	13.3	5.5		
				700	25.4	20.0	0.79	1.86	32.1	13.6					5.8									
	6.3	0.86	2.0	Operation not recommended							6.0	0.90	2.1	700	23.0	19.0	0.83	2.24	30.9	10.2	6.3			
				950	23.7	20.8	0.88	2.29	31.8	10.4				6.3										
	8.5	1.43	3.3	Operation not recommended							7.5	1.33	3.1	700	23.3	19.2	0.82	2.22	31.2	10.5	6.8			
				950	24.0	21.0	0.88	2.27	32.1	10.6				6.8										
120	4.5	0.45	1.0	Operation not recommended							120	4.0	0.31	0.7	700	22.4	18.7	0.83	2.74	32.1	8.2	8.2		
				950	22.9	20.4	0.89	2.80	32.8	8.2					8.2									
	6.3	0.83	1.9	Operation not recommended							6.0	0.86	2.0	700	22.7	18.9	0.83	2.59	31.8	8.8	8.4			
				950	23.1	20.5	0.89	2.66	32.5	8.7				8.4										
	8.5	1.38	3.2	Operation not recommended							7.5	1.28	3.0	700	22.9	18.9	0.82	2.51	31.8	9.1	8.7			
				950	22.3	20.3	0.91	2.53	30.0	8.8				8.7										

Performance capacities shown in thousands of Btuh.

Performance Data

060 - 100% Full Load

EWT °F	Flow gpm	WPD		HEATING - EAT 70°F							EWT °F	Flow gpm	WPD		COOLING - EAT 80/67 °F							
		PSI	FT	Airflow cfm	HC mBtuh	Power kW	HE MBtuh	LAT °F	COP	HWC MBtuh			PSI	FT	Airflow cfm	TC MBtuh	SC MBtuh	S/T Ratio	Power kW	HR MBtuh	EER	HWC MBtuh
20	8.5	2.00	4.6	Operation not recommended							20	6.5	1.21	2.8	Operation not recommended							
	13.0	3.52	8.1	Operation not recommended								10.0	2.70	6.2	Operation not recommended							
	17.0	6.55	15.1	1800	45.5	5.00	28.4	92.7	2.67	8.1		2200	46.5	4.97	29.5	88.8	2.74	7.5				
30	8.5	1.95	4.5	1800	45.8	4.19	31.5	92.9	3.21	8.4	30	6.5	1.17	2.7	1500	59.6	37.0	0.62	1.92	65.5	31.0	-
				2200	46.9	4.41	31.9	89.0	3.12	7.8					1800	60.7	40.6	0.67	2.00	66.9	30.4	-
	13.0	3.42	7.9	1800	49.0	4.23	34.6	94.6	3.40	8.6		10.0	2.62	6.1	1500	60.4	37.3	0.62	1.83	66.1	33.1	-
				2200	50.4	4.50	35.0	90.5	3.28	7.9		1800	61.4	40.8	0.66	1.92	67.3	31.9	-			
	17.0	6.36	14.7	1800	49.9	4.57	34.3	95.1	3.20	8.8		13.5	4.08	9.4	1500	60.7	37.3	0.61	1.77	66.2	34.3	-
				2200	48.5	4.16	34.2	88.9	3.41	8.0		1800	62.2	40.8	0.66	1.86	68.0	33.5	-			
40	8.5	1.90	4.4	1800	53.2	4.35	38.4	96.8	3.58	8.9	40	6.5	1.14	2.6	1500	60.6	39.5	0.65	2.24	67.5	27.0	-
				2200	54.4	4.53	39.0	92.2	3.52	8.2					1800	61.8	43.2	0.70	2.34	69.0	26.4	-
	13.0	3.32	7.7	1800	56.6	4.42	41.5	98.6	3.75	9.2		10.0	2.55	5.9	1500	61.3	39.9	0.65	2.13	67.9	28.8	-
				2200	57.9	4.61	42.2	93.7	3.68	8.4		1800	62.4	43.5	0.70	2.23	69.4	28.0	-			
	17.0	6.17	14.3	1800	57.5	4.50	42.1	99.1	3.74	9.5		13.5	3.96	9.1	1500	61.8	39.9	0.65	2.07	68.2	29.9	-
				2200	58.8	4.66	42.9	94.1	3.70	8.6		1800	63.2	43.5	0.69	2.16	69.9	29.2	-			
50	8.5	1.85	4.3	1800	60.6	4.52	45.2	100.8	3.93	9.5	50	6.5	1.10	2.5	1500	61.6	41.7	0.68	2.41	69.1	25.6	-
				2200	61.9	4.66	46.0	95.5	3.90	8.6					1800	62.8	45.3	0.72	2.56	70.8	24.5	-
	13.0	3.21	7.4	1800	64.1	4.60	48.4	102.6	4.08	9.9		10.0	2.47	5.7	1500	62.2	42.1	0.68	2.36	69.5	26.4	-
				2200	65.4	4.72	49.3	97.0	4.06	8.9		1800	63.5	45.8	0.72	2.50	71.2	25.3	-			
	17.0	5.98	13.8	1800	65.2	4.66	49.3	103.2	4.10	10.3		13.5	3.83	8.9	1500	62.8	42.6	0.68	2.32	70.0	27.1	-
				2200	66.6	4.77	50.3	97.5	4.09	9.3		1800	64.1	46.2	0.72	2.46	71.7	26.1	-			
60	8.5	1.80	4.2	1800	68.9	4.69	52.9	105.2	4.30	10.1	60	6.5	1.07	2.5	1500	59.2	40.9	0.69	2.71	67.6	21.8	3.1
				2200	70.4	4.77	54.1	99.2	4.33	9.0					1800	60.7	44.4	0.73	2.89	69.6	21.0	3.1
	13.0	3.11	7.2	1800	72.1	4.77	55.8	106.8	4.43	10.6		10.0	2.39	5.5	1500	59.8	41.3	0.69	2.66	68.0	22.5	2.9
				2200	73.6	4.83	57.1	100.6	4.47	9.5		1800	61.3	44.9	0.73	2.82	70.1	21.7	2.9			
	17.0	5.79	13.4	1800	73.6	4.82	57.2	107.7	4.47	11.1		13.5	3.71	8.6	1500	60.4	41.7	0.69	2.61	68.5	23.1	2.7
				2200	75.3	4.88	58.6	101.3	4.52	9.9		1800	61.9	45.3	0.73	2.78	70.5	22.3	2.7			
70	8.5	1.75	4.0	1800	77.2	4.86	60.6	109.6	4.65	10.6	70	6.5	1.03	2.4	1500	56.7	40.1	0.71	3.01	66.1	18.8	4.6
				2200	77.4	4.89	60.7	102.2	4.64	9.5					1800	58.1	44.0	0.76	3.52	69.0	16.5	4.6
	13.0	3.01	7.0	1800	80.0	4.93	63.2	111.1	4.76	11.2		10.0	2.31	5.3	1500	57.3	40.5	0.71	2.96	66.5	19.4	4.3
				2200	81.8	4.94	65.0	104.1	4.85	10.0		1800	59.1	43.9	0.74	3.14	68.9	18.8	4.3			
	17.0	5.60	12.9	1800	82.1	4.99	65.0	112.1	4.82	11.9		13.5	3.59	8.3	1500	57.8	40.8	0.71	2.90	66.9	19.9	4.2
				2200	80.0	5.02	62.8	102.9	4.67	10.6		1800	59.7	44.4	0.74	3.26	69.3	18.3	4.1			
80	8.5	1.68	3.9	1800	86.0	5.14	68.5	114.2	4.90	11.8	80	6.5	0.99	2.3	1500	52.9	38.8	0.73	3.45	63.6	15.4	6.1
				2200	88.0	5.11	70.5	106.8	5.05	9.9					1800	54.9	42.2	0.77	3.67	66.3	14.9	6.1
	13.0	2.91	6.7	1800	88.0	5.20	70.3	115.3	4.96	12.2		10.0	2.23	5.2	1500	53.5	39.2	0.73	3.38	64.0	15.8	5.8
				2200	90.1	5.15	72.6	107.7	5.13	10.6		1800	55.4	42.6	0.77	3.59	66.6	15.4	5.8			
	17.0	5.41	12.5	1800	90.7	5.26	72.7	116.7	5.05	12.6		13.5	3.47	8.0	1500	54.0	39.6	0.73	3.32	64.3	16.3	5.5
				2200	93.0	5.20	75.2	109.0	5.24	11.2		1800	56.0	43.0	0.77	3.54	67.0	15.8	5.5			
90	8.5	1.60	3.7	1800	94.8	5.42	76.3	118.9	5.13	11.7	90	6.5	0.96	2.2	1500	49.1	37.6	0.77	3.88	61.1	12.7	8.2
				2200	97.0	5.33	78.8	110.7	5.33	10.3					1800	51.3	40.8	0.80	4.13	64.1	12.4	8.2
	13.0	2.80	6.5	1800	96.0	5.47	77.4	119.6	5.14	12.6		10.0	2.15	5.0	1500	49.7	37.9	0.76	3.80	61.4	13.1	7.8
				2200	98.4	5.36	80.1	111.3	5.38	11.1		1800	51.7	41.2	0.80	4.05	64.3	12.8	7.8			
	17.0	5.22	12.1	1800	99.3	5.54	80.4	121.3	5.25	13.4		13.5	3.34	7.7	1500	50.7	38.2	0.75	3.85	62.6	13.2	7.3
				2200	96.3	5.31	78.3	109.8	5.32	11.9		1800	52.3	41.6	0.80	3.98	64.7	13.1	7.4			
100	8.5	1.55	3.6	Operation not recommended							100	6.5	0.92	2.1	1500	44.7	36.4	0.81	4.43	58.4	10.1	10.3
	13.0	2.70	6.2	Operation not recommended								10.0	2.07	4.8	1500	45.2	36.7	0.81	4.33	58.6	10.4	9.7
	17.0	5.03	11.6	Operation not recommended								13.5	3.22	7.5	1500	45.6	37.1	0.81	4.26	58.8	10.7	9.2
				1800	47.8	40.3	0.84	4.54	61.9	10.5		9.2										
110	8.5	1.50	3.5	Operation not recommended							110	6.5	0.89	2.1	1500	40.3	35.2	0.87	4.97	55.7	8.1	13.0
				1800	42.4	38.2	0.90	5.30	58.9	8.0					13.1							
	13.0	2.60	6.0	Operation not recommended								10.0	2.00	4.6	1500	40.7	35.5	0.87	4.87	55.8	8.4	12.3
				1800	42.9	38.6	0.90	5.19	59.0	8.3		12.4										
17.0	4.84	11.2	Operation not recommended							13.5	3.10	7.2	1500	41.1	35.9	0.87	4.78	55.9	8.6	11.6		
			1800	43.3	39.0	0.90	5.10	59.1	8.5	11.7												
120	8.5	1.40	3.2	Operation not recommended							120	6.5	0.85	2.0	1500	38.7	34.1	0.88	6.10	57.6	6.4	16.1
				1800	39.6	37.1	0.94	6.24	58.9	6.3					16.2							
	13.0	2.50	5.8	Operation not recommended								10.0	1.92	4.4	1500	39.2	34.4	0.88	5.76	57.1	6.8	15.2
				1800	39.9	37.3	0.93	5.91	58.3	6.8		15.3										
17.0	4.65	10.7	Operation not recommended							13.5	2.98	6.9	1500	39.6	34.4	0.87	5.58	56.9	7.1	14.3		
			1800	40.4	37.3	0.92	5.75	58.2	7.0	14.5												

Performance capacities shown in thousands of Btuh.

Service Parts List

Parts List - Horizontal		024	036	048	060
Compressor	Compressor 208-230/60/1	34P676-01	34P676-01	34P677-01	34P678-01
	Sound Jacket	92P504A05	92P504A05	92P504A05	92P504A05
	Power Harness	11P853-01	11P853-01	11P853-01	11P853-01
ECM EON Motor & Blower	ECM Motor 208-230/60/1	14S575-01	14S575-01	14S576-01	14S577-01
	ECM Blower Housing	53P501B01	53P501B01	53P501B01	53P501B01
	ECM Harness - Low Voltage	11P827-01	11P827-01	11P827-01	11P827-01
	ECM Power Harness	11P585B04	11P585B04	11P585B04	11P585B04
Air Filters	2" Air Filter MERV 11	59P509-02	59P509-02	59P509-02	59P509-03
	2" Air Filter MERV 11 (second filter if needed)	59P509-11	59P509-11	59P509-11	59P509-11
Refrigeration Components	Air Coil	61P775-41S	61P775-41S	61P775-41S	61P776-41S
	Reheat Coil (OptiDry only)	n/a	61P660-01	61P660-01	61P661-01
	Coax	62I628-01	62I628-01	62I555-01	62I555-01
	EEV	33P617-01	33P617-01	33P617-01	33P617-01
	Reversing Valve	33P526-05	33P526-05	33P526-05	33P526-05
	Reheat Valve (OptiDry only)	n/a	33P629-04	33P629-04	33P629-04
	Check Valve (OptiDry only)	n/a	33P589B03	33P589B03	33P589B03
	Discharge Muffler	36P503B02	36P503B02	36P503B02	36P503B02
Filter Dryer	36P500B01	36P500B01	36P500B02	36P500B02	
Hot Water Generator	Hot Water Generator	62P516-03	62P516-03	62P516-03	62P516-03
	Hot Water Generator Pump	24P501A01	24P501A01	24P501A01	24P501A01
Electrical	2 POLE CONTACTOR 24 VAC-40A	13P521-01	13P521-01	13P521-01	13P521-01
	TRNSFMR 100VAC 208-240 24V LEAD	15P531-01	15P531-01	15P531-01	15P531-01
	3 Pole Power Block	12P503-06	12P503-06	12P503-06	12P503-06
	2 Pole Screw Term. Block	12P500A01	12P500A01	12P500A01	12P500A01
	EEV Solenoid Coil	33P617-02	33P617-02	33P617-02	33P617-02
	EEV/VS Drive Communication Cable	11P843-01	11P843-01	11P843-01	11P843-01
	ASB/ABC/AXB/Drive Communication Harness	11P836-02	11P836-02	11P836-02	11P836-02
	RDS/ASB Harness	11P991-02	11P991-02	11P991-02	11P991-02
	Keystone Category 5 Coupler (AID Port)	12P553-01	12P553-01	12P553-01	12P553-01
	Category 5 cable (AID Port to ABC)	11P846-01	11P846-01	11P846-01	11P846-01
	Current Transformer	12P557-01	12P557-01	12P557-01	12P557-01
	Rocker Switch - HWG ON/OFF	13P607A01	13P607A01	13P607A01	13P607A01
	Pump Circuit Breaker - 5 amp, 250v	19P583-01	19P583-01	19P583-01	19P583-01
	Pressure Transmitter DIN Cable	11P855-01	11P855-01	11P855-01	11P855-01
	VS Drive Control	17P560-07	17P560-07	17P560-08	17P560-09
	Drive Circuit Breaker	19P595-01	19P595-01	19P595-02	19P595-03
	ABC Board	17X553-36	17X553-36	17X553-36	17X553-36
	AXB Board	17X597-26	17X597-26	17X597-26	17X597-26
	ABC Board (OptiDry Only)	n/a	17X553-41	17X553-41	17X553-41
	AXB Board (OptiDry Only)	n/a	17X597-27	17X597-27	17X597-27
ASB Board	17P599-01	17P599-01	17P599-01	17P599-01	
Power Supply/EEV Board (OptiDry only)	n/a	17P568-02	17P568-02	17P568-02	
IB-G Board (OptiDry only)	n/a	17P874-01	17P874-01	17P874-01	
Sensors & Safeties	Freeze Detection Thermistor-FP1-Yellow	FP1RK01	FP1RK01	FP1RK01	FP1RK01
	HWL Thermistor-Pink (AXB P17)	12P555-04	12P555-04	12P555-04	12P555-04
	Thermistor FP2	12P550-01	12P550-01	12P550-01	12P550-01
	Thermistor - LAT/EWT/Suct Line/Compr Ambient	12P555-06	12P555-06	12P555-06	12P555-06
	Thermistor - Suction Line	12P555-05	12P555-05	12P555-05	12P555-05
	Thermistor - Compressor Discharge Line	12P556-02	12P556-02	12P556-02	12P556-02
	Thermistor - Heating Liquid Line	12P555-03	12P555-03	12P555-03	12P555-03
	Thermistor - Leaving Water Temperature	12P555-02	12P555-02	12P555-02	12P555-02
	Transmitter, Flow Meter (sensor, clip, harness)	29P535-01	29P535-01	29P535-01	29P535-01
	Pressure Transducer Replacement, High and Low Pressure	35P558-01	35P558-01	35P558-01	35P558-01
	Switch, High Pressure	SKHPE600	SKHPE600	SKHPE600	SKHPE600
	Switch, Low Pressure	SKLPE40	SKLPE40	SKLPE40	SKLPE40
Refrigerant Detection Sensor	19P688-01	19P688-01	19P688-01	19P688-01	
Misc.	VS Drive Fan Filter	59P512-01	59P512-01	59P512-01	59P512-01

Part numbers subject to change

8/16/24

Service Parts List

Parts List - Vertical		024	036	048	060
Compressor	Compressor 208-230/60/1	34P676-01	34P676-01	34P677-01	34P678-01
	Sound Jacket	92P504A05	92P504A05	92P504A05	92P504A05
	Power Harness	11P853-01	11P853-01	11P853-01	11P853-01
ECM Motor & Blower	ECM Motor 208-230/60/1	14S575-01	14S575-01	14S576-01	14S577-01
	ECM Blower Housing	53P501B01	53P501B01	53P501B01	53P501B01
	ECM Harness - Low Voltage	11P827-02	11P827-02	11P827-02	11P827-02
	ECM Power Harness	11P585B03	11P585B03	11P585B03	11P585B03
Air Filters	2" Air Filter MERV 11 (top flow & rear discharge)	59P509-07	59P509-07	59P509-07	59P509-06
	2" Air Filter MERV 11 (bottom flow)	59P509-06	59P509-06	59P509-06	59P509-06
	AP411 4" Media Refill	RM-AP411-46	RM-AP411-46	RM-AP411-46	RM-AP411-46
	AP411 1" Carbon Media Refill	RM-AP411-46C	RM-AP411-46C	RM-AP411-46C	RM-AP411-46C
Refrigeration Components	Air Coil	61P773-41S	61P773-41S	61P773-41S	61P772-41S
	Reheat Coil (OptiDry only)	n/a	61P759-01	61P759-01	61P760-01
	Coax	62I628-01	62I628-01	62I555-01	62I555-01
	EEV	33P617-01	33P617-01	33P617-01	33P617-01
	Reversing Valve	33P526-05	33P526-05	33P526-05	33P526-05
	Reheat Valve (OptiDry only)	n/a	33P629-04	33P629-04	33P629-04
	Check Valve (OptiDry only)	n/a	33P589B03	33P589B03	33P589B03
	Discharge Muffler	36P503B02	36P503B02	36P503B02	36P503B02
Filter Dryer	36P500B01	36P500B01	36P500B02	36P500B02	
Hot Water Generator	Hot Water Generator	62P516-03	62P516-03	62P516-03	62P516-03
	Hot Water Generator Pump	24P501A01	24P501A01	24P501A01	24P501A01
Electrical	2 POLE CONTACTOR 24 VAC-40A	13P521-01	13P521-01	13P521-01	13P521-01
	TRNSFMR 100VAC 208-240 24V LEAD	15P531-01	15P531-01	15P531-01	15P531-01
	3 Pole Power Block	12P503-06	12P503-06	12P503-06	12P503-06
	2 Pole Screw Term. Block	12P500A01	12P500A01	12P500A01	12P500A01
	EEV Solenoid Coil	33P617-02	33P617-02	33P617-02	33P617-02
	ASB/ABC/AXB/Drive Communication Harness	11P836-02	11P836-02	11P836-02	11P836-02
	RDS/ASB Harness	11P991-02	11P991-02	11P991-02	11P991-02
	Keystone Category 5 Coupler (AID Port)	12P553-01	12P553-01	12P553-01	12P553-01
	Category 5 cable (AID Port to ABC)	11P846-01	11P846-01	11P846-01	11P846-01
	Current Transformer	12P557-01	12P557-01	12P557-01	12P557-01
	Rocker Switch - HWG ON/OFF	13P607A01	13P607A01	13P607A01	13P607A01
	Pump Circuit Breaker - 5 amp, 250v	19P583-01	19P583-01	19P583-01	19P583-01
	Pressure Transmitter DIN Cable	11P855-01	11P855-01	11P855-01	11P855-01
	VS Drive Control	17P560-07	17P560-07	17P560-08	17P560-09
	Drive Circuit Breaker	19P595-01	19P595-01	19P595-02	19P595-03
	ABC Board	17X553-36	17X553-36	17X553-36	17X553-36
	AXB Board	17X597-26	17X597-26	17X597-26	17X597-26
	ABC Board (OptiDry Only)	n/a	17X553-41	17X553-41	17X553-41
	AXB Board (OptiDry Only)	n/a	17X597-27	17X597-27	17X597-27
	ASB Board	17P599-01	17P599-01	17P599-01	17P599-01
Power Supply/EEV Board (OptiDry only)	n/a	17P568-02	17P568-02	17P568-02	
IB-G Board (OptiDry only)	n/a	17P874-01	17P874-01	17P874-01	
Sensors & Safeties	Freeze Detection Thermistor-FP1-Yellow	FPIRK01	FPIRK01	FPIRK01	FPIRK01
	HWL Thermistor-Pink (AXB P17)	12P555-04	12P555-04	12P555-04	12P555-04
	Thermistor FP2	12P550-01	12P550-01	12P550-01	12P550-01
	Thermistor - LAT/EWT/Suct Line/Compr Ambient	12P555-06	12P555-06	12P555-06	12P555-06
	Thermistor - Suction Line	12P555-05	12P555-05	12P555-05	12P555-05
	Thermistor - Compressor Discharge Line	12P556-02	12P556-02	12P556-02	12P556-02
	Thermistor - Heating Liquid Line	12P555-03	12P555-03	12P555-03	12P555-03
	Thermistor - Leaving Water Temperature	12P555-02	12P555-02	12P555-02	12P555-02
	Transmitter, Flow Meter (sensor, clip, harness)	29P535-01	29P535-01	29P535-01	29P535-01
	Pressure Transducer Replacement, High and Low Pressure	35P558-01	35P558-01	35P558-01	35P558-01
	Switch, High Pressure	SKHPE600	SKHPE600	SKHPE600	SKHPE600
	Switch, Low Pressure	SKLPE40	SKLPE40	SKLPE40	SKLPE40
	Refrigerant Detection Sensor	19P688-01	19P688-01	19P688-01	19P688-01
Miscellaneous	VS Drive Fan Filter	59P512-01	59P512-01	59P512-01	59P512-01

Part numbers subject to change

8/16/24

Decommissioning

Before carrying out this procedure, it is essential that the technician is completely familiar with the equipment and all its detail. It is recommended good practice that all refrigerants are recovered safely. Prior to the task being carried out, an oil and refrigerant sample shall be taken in case analysis is required prior to re-use of recovered refrigerant. It is essential that electrical power is available before the task is commenced.

1. Become familiar with the equipment and its operation.
2. Isolate system electrically.
3. Before attempting the procedure, ensure that:
 - mechanical handling equipment is available, if required, for handling refrigerant cylinders;
 - all personal protective equipment is available and being used correctly;
 - the recovery process is supervised at all times by a competent person;
 - recovery equipment and cylinders conform to the appropriate standards.
4. Pump down refrigerant system, if possible.
5. If a vacuum is not possible, make a manifold so that refrigerant can be removed from various parts of the system.
6. Make sure that cylinder is situated on the scales before recovery takes place.
7. Start the recovery machine and operate in accordance with instructions.
8. Do not overfill cylinders (no more than 80 % volume liquid charge).
9. Do not exceed the maximum working pressure of the cylinder, even temporarily.
10. When the cylinders have been filled correctly and the process completed, make sure that the cylinders and the equipment are removed from site promptly and all isolation valves on the equipment are closed off.
11. Recovered refrigerant shall not be charged into another REFRIGERATING SYSTEM unless it has been cleaned and checked

Decommissioning - Unit Labeling Requirements

Equipment shall be labelled stating that it has been de-commissioned and emptied of refrigerant. The label shall be dated and signed. For appliances containing FLAMMABLE REFRIGERANTS, ensure that there are labels on the equipment stating the equipment contains FLAMMABLE REFRIGERANT.

Refrigerant Recovery

When removing refrigerant from a system, either for servicing or decommissioning, it is recommended good practice that all refrigerants are removed safely.

When transferring refrigerant into cylinders, ensure that only appropriate refrigerant recovery cylinders are employed. Ensure that the correct number of cylinders for holding the total system charge is available. All cylinders to be used are designated for the recovered refrigerant and labelled for that refrigerant (i.e. special cylinders for the recovery of refrigerant). Cylinders shall be complete with pressure-relief valve and associated shut-off valves in good working order. Empty recovery cylinders are evacuated and, if possible, cooled before recovery occurs.

The recovery equipment shall be in good working order with a set of instructions concerning the equipment that is at hand and shall be suitable for the recovery of the flammable refrigerant. If in doubt, the manufacturer should be consulted. In addition, a set of calibrated weighing scales shall be available and in good working order. Hoses shall be complete with leak-free disconnect couplings and in good condition.

The recovered refrigerant shall be processed according to local legislation in the correct recovery cylinder, and the relevant waste transfer note arranged. Do not mix refrigerants in recovery units and especially not in cylinders.

If compressors or compressor oils are to be removed, ensure that they have been evacuated to an acceptable level to make certain that flammable refrigerant does not remain within the lubricant. The compressor body shall not be heated by an open flame or other ignition sources to accelerate this process. When oil is drained from a system, it shall be carried out safely.

Refrigerant Removal and Evacuation

When breaking into the refrigerant circuit to make repairs – or for any other purpose conventional procedures shall be used. However, for flammable refrigerants it is important that best practice be followed, since flammability is a consideration.

The following procedure shall be adhered to:

- safely remove refrigerant following local and national regulations;
- evacuate;
- purge the circuit with inert gas (optional for A2L);
- evacuate (optional for A2L);
- continuously flush or purge with inert gas when using flame to open circuit; and
- open the circuit.

The refrigerant charge shall be recovered into the correct recovery cylinders if venting is not allowed by local and national codes. For appliances containing flammable refrigerants, the system shall be purged with oxygen-free nitrogen to render the appliance safe for flammable refrigerants.

This process might need to be repeated several times. Compressed air or oxygen shall not be used for purging refrigerant systems. For appliances containing flammable refrigerants, refrigerants purging shall be achieved by breaking the vacuum in the system with oxygen-free nitrogen and continuing to fill until the working pressure is achieved, then venting to atmosphere, and finally pulling down to a vacuum (optional for A2L). This process shall be repeated until no refrigerant is within the system (optional for A2L). When the final oxygen-free nitrogen charge is used, the system shall be vented down to atmospheric pressure to enable work to take place. The outlet for the vacuum pump shall not be close to any potential ignition sources, and ventilation shall be available.

Charging procedures

In addition to conventional charging procedures, the following requirements shall be followed.

- Ensure that contamination of different refrigerants does not occur when using charging equipment.
- Hoses or lines shall be as short as possible to minimise the amount of refrigerant contained in them.
- Cylinders shall be kept in an appropriate position according to the instructions.
- Ensure that the REFRIGERATING SYSTEM is earthed prior to charging the system with refrigerant.
- Label the system when charging is complete (if not already).
- Extreme care shall be taken not to overfill the REFRIGERATING SYSTEM.

Prior to recharging the system, it shall be pressure-tested with the appropriate purging gas. The system shall be leak-tested on completion of charging but prior to commissioning. A follow up leak test shall be carried out prior to leaving the site.

Notes

Revision Guide

Pages:	Description:	Date:	By:
All	Document Creation	16 Feb 2024	SW



Manufactured by
WaterFurnace International, Inc.
9000 Conservation Way
Fort Wayne, IN 46809
www.waterfurnace.com



OM7W-0018W 08/24

Product:	7 Series
Type:	60 Hz
Size:	3-6 Tons
Document:	Operation & Maintenance Manual