



Specification Catalog

ENVISION™

GEOTHERMAL HYDRONIC HEAT PUMP
8 TO 15 TONS

Table of Contents

Model Nomenclature	4
AHRI Data	5
The Two-Stage Hydronic Series	7
Inside the the Two-Stage Hydronic Series.	9
Aurora Based Control System	10
Application Notes	18
Flow Rates	25
Water Quality	26
Two-Stage Hydronic Typical Application Piping	27
Dimensional Data.	28
Physical Data	29
Electrical Data	30
Reference Calculations	31
Legend and Notes	31
Antifreeze Correction	32
Load and Source Pressure Drop	33
Performance Data	34
Wiring Schematics.	42
Accessories and Options	54
Engineering Guide Specifications.	57
Revision Guide	59

Model Nomenclature

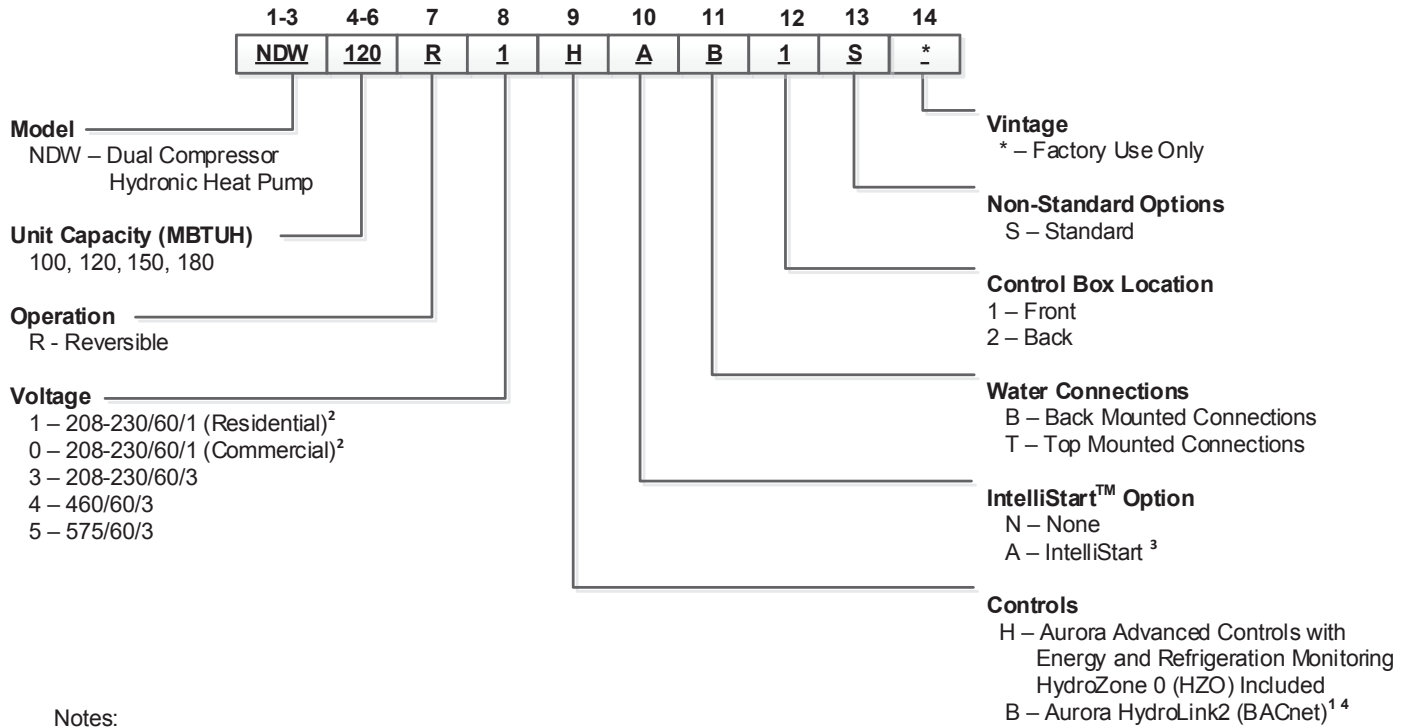

- Notes:
- 1 – Aurora HydroLink2 controls available for commercial units only.
 - 2 – Dual power feed required.
 - 3 – IntelliStart Option available for single phase voltage options only.
 - 4 – HydroLink2 control option available to Commercial Reps only.

Rev.: 10 Oct 2020B



All Envision Series product is safety listed under UL1995 thru ETL and performance listed with AHRI in accordance with standard 13256-2. The Envision Series is also Energy Star rated.

AHRI Data

AHRI/ASHRAE/ISO 13256-2
English (IP) Units

Model	Capacity Modulation	Flow Rate		Water Loop Heat Pump				Ground Water Heat Pump				Ground Loop Heat Pump			
				Cooling EST 86°F ELT 53.6°F		Heating EST 68°F ELT 104°F		Cooling EST 59°F ELT 53.6°F		Heating EST 50°F ELT 104°F		Cooling Full EST 77°F Part EST 68°F ELT 53.6°F		Heating Full EST 32°F Part ELT 41°F ELT 104°F	
		Sgpm	Lgpm	Capacity Btuh	EER Btuh/W	Capacity Btuh	COP	Capacity Btuh	EER Btuh/W	Capacity Btuh	COP	Capacity Btuh	EER Btuh/W	Capacity Btuh	COP
100	Full	23	23	93,000	14.6	125,000	4.0	105,000	22.0	103,000	3.3	100,000	16.8	82,000	3.0
	Part	23	23	50,000	15.8	65,000	4.6	56,000	24.5	53,000	3.7	54,000	22.0	47,000	3.4
120	Full	28	28	103,000	14.0	142,000	4.0	123,000	21.6	118,000	3.3	114,000	16.2	93,000	3.0
	Part	28	28	58,000	15.5	76,000	4.4	65,000	22.4	62,500	3.7	63,000	21.1	55,000	3.4
150	Full	32	32	129,000	13.5	199,000	4.0	153,000	21.1	148,000	3.2	147,000	16.0	123,000	2.8
	Part	32	32	72,000	15.3	101,000	4.3	75,000	22.0	73,000	3.7	78,000	20.7	70,000	3.3
180	Full	36	36	150,000	13.3	221,000	3.9	175,000	19.8	173,000	3.1	165,000	15.8	139,000	2.7
	Part	36	36	78,000	15.0	113,000	4.2	89,000	20.9	87,000	3.7	86,000	18.4	82,000	3.5

All ratings based upon 208V operation.

3/21/11

Energy Star Compliance Table

Model	Tier 3	
	Ground Water	Ground Loop
100	Yes	Yes
120	Yes	Yes
150	No	No
180	No	No

12/17/10

Energy Star Rating Criteria

In order for water-source heat pumps to be Energy Star rated they must meet or exceed the minimum efficiency requirements listed below.

Tier 3: 1/1/2012 - No Effective End Date Published

	EER	COP
Closed loop water-to-air	17.1	3.6
Open loop water-to-air	21.1	4.1
Closed loop water-to-water	16.1	3.1
Open loop water-to-water	20.1	3.5

AHRI Data cont.

The performance standard AHRI/ASHRAE/ISO 13256-2 became effective January 1, 2000. This new standard has three major categories: Water Loop, Ground Water, and Ground Loop.

Unit of Measure: The Cooling COP

The cooling efficiency is measured in EER (US version measured in Btuh per Watt. The Metric version is measured in a cooling COP (Watt per Watt) similar to the traditional COP measurement.

Pump Power Correction Calculation

Within each model, only one water flow rate is specified for all three groups and pumping Watts are calculated using the following formula. This additional power is added onto the existing power consumption.

- Pump power correction = (gpm x 0.0631) x (Press Drop x 2990) / 300

Where 'gpm' is waterflow in gpm and 'Press Drop' is the pressure drop through the unit heat exchanger at rated water flow in feet of head.

ISO Capacity and Efficiency Calculations

The following equations illustrate cooling calculations:

- ISO Cooling Capacity = Cooling Capacity (Btuh) x 3.412
- ISO EER Efficiency (W/W) = ISO Cooling Capacity (Btuh) x 3.412 / [Power Input (Watts) + Pump Power Correction (Watt)]

The following equations illustrate heating calculations:

- ISO Heating Capacity = Heating Capacity (Btuh) x 3.412
- ISO COP Efficiency (W/W) = ISO Heating Capacity (Btuh) x 3.412 / [Power Input (Watts) + Pump Power Correction (Watt)]

Test Conditions

	ISO/AHRI 13256-2 WLHP	ISO/AHRI 13256-2 GWHP	ISO/AHRI 13256-2 GLHP
Cooling			
Liquid Entering Indoor Side - °F	53.6	53.6	53.6
<i>Standard Rating Test</i>			
Liquid Entering Heat Exchanger - °F	86	59	77
<i>Part-load Rating Test</i>			
Liquid Entering Heat Exchanger	86	59	68
Fluid Flow Rate	*	*	*
Heating			
Liquid Entering Indoor Side - °F	104	104	104
<i>Standard Rating Test</i>			
Liquid Entering Outdoor-side Heat Exchanger - °F	68	50	32
<i>Part-load Rating Test</i>			
Liquid Entering Outdoor-side Heat Exchanger	68	50	41
Fluid Flow Rate	*	*	*

Conversions

Water Flow (lps) = GPM x 0.0631

Press Drop (Pascals) = Press Drop (ft hd) x 2990

NOTES: *Flow rate is specified by the manufacturer
 WLHP = Water Loop Heat Pump; GWHP = Ground Water Heat Pump;
 GLHP = Ground Loop Heat Pump

The Two-Stage Hydronic Series

Features

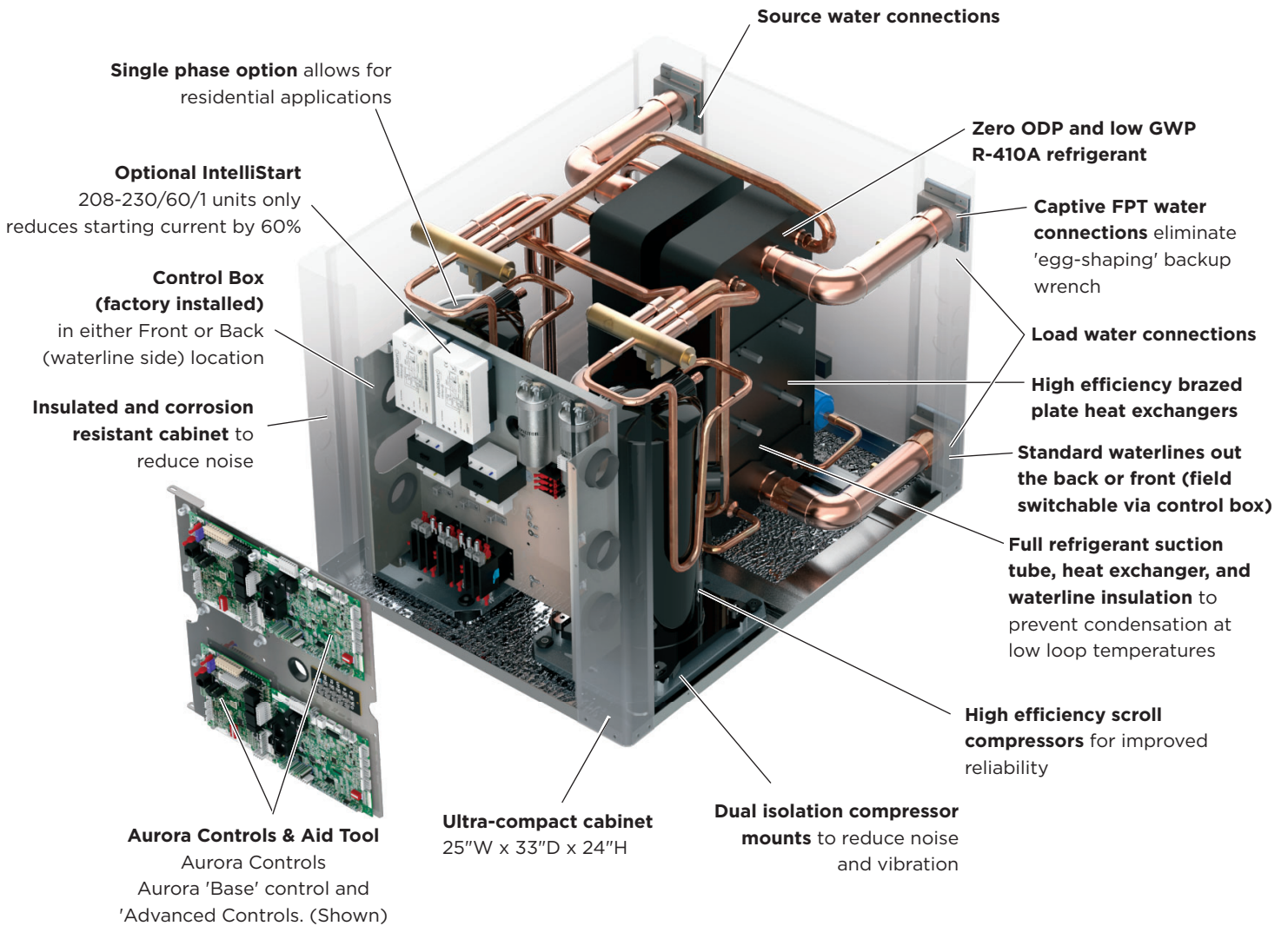

The Two-Stage Hydronic Series

High Efficiency

The Two-Stage Hydronic Series are the highest efficiency units available. Large oversized water to refrigerant heat exchangers and scroll compressors provide extremely efficient operation. This efficiency means the Two-Stage Hydronic Series requires less loop than any product on the market. This can mean significant savings on commercial and residential projects.

Standard Features

- Single phase is available.
- Heavy gauge cabinet
- Quiet scroll compressors in all models
- Two-dimension refrigerant piping vibration loops to isolate the compressor.
- All interior cabinet surfaces are insulated with 1/2 in. [12.7 mm] thick 1-1/2 lb [681 g] density, surface coated, acoustic type glass fiber insulation.
- Optional IntelliStart to reduce starting current
- Optional Front or Back (waterline side) mounted control box
- Aurora Advanced Controls
- Ultra-compact cabinet
- Optional top or back mounted water lines

Super Quiet Option

- Multi-density laminate lined compressor blanket designed to suppress low frequency noise.



Aurora™ Communicating Control Features

- *Traditional Safety Sensors:* HP, LP, freeze detection loop, freeze detection load.
- *Communicating Modular Design:* Communicating modular design for flexibility and expandability

Easy Maintenance and Service Advantages

- Removable compressor access panels.
- Quick attach wiring harnesses are used throughout for fast servicing.
- High and low pressure refrigerant service ports.

Factory Quality

- All refrigerant brazing is performed in a nitrogen purge environment.
- Computer controlled deep vacuum and refrigerant charging system.
- All joints are leak detected for maximum leak rate of less than 1/4 oz. per year.
- Computer bar code equipped assembly line insures all components are correct.

All units are computer run-tested with water to verify both function and performance.



Inside the Two-Stage Hydronic Series

Refrigerant

Hydronic products all feature zero ozone depletion and low global warming potential R-410A refrigerant.

Cabinet

All units are constructed of corrosion resistant galvanized sheet metal with silver metallic powder coat paint rated for more than 1000 hours of salt spray. Large lift-out access panels provide access to the compressor section from four sides. Back or top water connection option is available.

Compressors

High efficiency R-410A scroll compressors are used on every model. Scrolls provide both the highest efficiency available and great reliability.

Electrical Box

Unit controls feature quick connect wiring harnesses for easy servicing. Separate knockouts for low voltage, and two for power on two sides allow easy access to the control box. Two large 75VA transformers assure adequate control's power for accessories. Aurora Advanced controls are included, featuring several innovations.

Water Connections

Flush mount FPT water connection fittings allow one wrench leak-free connections and do not require a backup wrench. Factory installed thermistors are used on all water lines and can be viewed through the microprocessor interface tool.

Thermostatic Expansion Valve

All Two-Stage Hydronic models utilize a balanced port bi-directional thermostatic expansion valve (TXV) for refrigerant metering. This allows precise refrigerant flow in a wide range of entering water variation (20 to 120°F [-7 to 49°C]) found in geothermal systems. The TXV is located in the compressor compartment for easy access.



Water-to-Refrigerant Heat Exchanger

Large oversized stainless steel interlaced copper-brazed plate water-to-refrigerant heat exchangers provide unparalleled efficiency. The heat exchangers have common water circuits with isolated refrigerant circuits so that in part load operation, the full mass of the heat exchanger is utilized. All heat exchangers are pressure rated to 450 psi water side and 650 psi refrigerant side. All heat exchangers, water lines, and suction lines



are insulated to prevent condensation during low temperature inlet water operation.

Service Connections and Serviceability

Two Schrader service ports are provided for each circuit on every unit. The suction side and discharge side ports are for field charging and servicing access. All valves are 7/16 in. SAE connections.



4-Way Reversing Valve

Two-Stage Hydronic units feature a reliable all-brass pilot operated refrigerant reversing valve. The reversing valve operation is limited to change of mode by the control to enhance reliability.

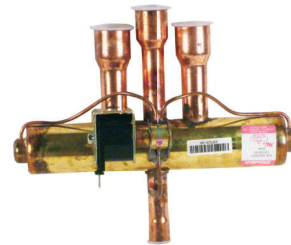

IntelliStart

The optional IntelliStart single phase soft starter will reduce the normal start current (LRA) by 60%. This allows the heat pump to go off-grid. Using IntelliStart also provides a substantial reduction in light flicker, reduces start-up noise, and improves the compressor's start behavior. IntelliStart is available in a field retrofit kit or as a factory installed option for all Two-Stage Hydronic units.

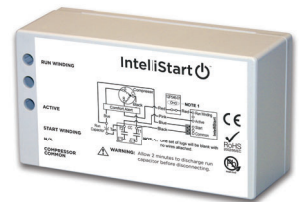

The Aurora Base Control System

Aurora ‘Base’ Control

The Aurora ‘Base’ Control (ABC) System is a complete residential and commercial comfort system that brings all aspects of the HVAC system into one cohesive module network. The ABC features microprocessor control and HP, LP, condensate and freeze detection, over/under voltage faults, along with communicating thermostat capability for complete fault detection text at the thermostat.

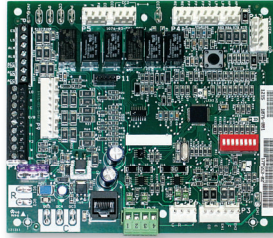

Aurora uses the Modbus communication protocol to communicate between modules. Each module contains the logic to control all features that are connected to the module. The Aurora ‘Base’ Control (ABC) has two Modbus channels. The first channel is configured as a master for connecting to devices such as a communicating thermostat, expansion board, or other slave devices. The second channel is configured as a slave for connecting the Aurora Interface Diagnostics Tool (AID Tool).

Aurora ‘Advanced’ Control

The Aurora ‘Advanced’ Control expands on the capability of the Aurora ‘Base’ Control (ABC) System by adding the Aurora Expansion Board (AXB). The additional features include compressor current monitoring, loop pump linking, intelligent hot water generator control, variable speed pump capability, and also allows for optional energy, refrigeration, and performance monitoring factory installed add-on sensor kits. The AXB also features a second field configurable accessory relay, and two home automation inputs that are AID configurable for different types of alarms from sump pumps to home security. The Smart Grid input is AID configurable with many options to react to Utility controlled relay operation for ON Peak optimization.

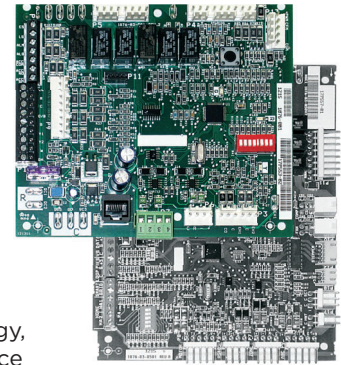

Aurora Control Features	Description	Aurora ‘Base’	Aurora ‘Advanced’
Microprocessor Compressor Control	Microprocessor control of compressor for timings with FP1, HP, LP, Condensate, assignable Acc relay	•	•
Advanced Microprocessor Features	Smart Grid, Home Automation Alarm Inputs, and Accessory2 Relay (HRV/ERV)	-	•
Base Loop Pump Control	Compressor Contactor powers Loop Pump and no loop pump linking capability.	•	See below
Compressor Monitoring	Control monitors compressor starts for high current, missing leg etc.	-	•
Smart Grid/Utility Input	Allows simple input to externally enable of occupied/unoccupied mode for basic utility time of use programs.	-	Dry Contact x1

The Aurora Base Control System cont.

Service Device	Description	Aurora 'Base'	Aurora 'Advanced'
 <p>Aurora Interface and Diagnostics (AID) Tool</p>	<p>Allows setup, monitoring and troubleshooting of any Aurora Control.</p> <p>NOTE: Although the ABC has basic compatibility with all Aurora, new product features may not be available on older AID Tools. To simplify the basic compatibility ensure the version of AID is at least the same or greater than the ABC software version.</p>	For Service (Ver. 1.xx or greater)	For Service (Ver. 2.xx or greater)

Add On Control Feature Kits (factory installed)	Description	Aurora 'Base'	Aurora 'Advanced'
Geo Energy Monitoring Kit	Monitors realtime power consumption of compressor, aux heat and pump. AXB required.	-	Standard
Refrigeration Monitoring Kit	Monitors realtime pressures, temperatures, superheat, and subcooling. AXB required.	-	Standard
Performance Monitoring Kit	Monitors water temperatures	-	Standard
Data Logging (AWL) Kit	Allows data logging of up to 12 months. Can also be temporarily installed for troubleshooting.	-	Optional

Add On Thermostats and Zoning	Description	Aurora 'Base'	Aurora 'Advanced'
HZO	Non-communicating controller for up to two heat pumps.	Standard	Standard

The Aurora Base Control System cont.

Aurora ‘Base’ Control

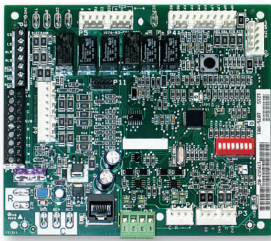

NOTE: Refer to the Aurora Base Control Application and Troubleshooting Guide and the Instruction Guide: Aurora Interface and Diagnostics (AID) Tool for additional information.

Control Features

- Random start at power up
- Anti-short cycle protection
- High and low pressure cutouts
- Loss of charge
- Water coil freeze detection
- Over/under voltage protection
- Load shed
- Emergency shutdown
- Diagnostic LED
- Test mode push button switch
- Alarm output
- Accessory output with N.O. and N.C.
- Modbus communication

Field Selectable Options via Hardware

DIP Switch (SW1) – Test/Configuration Button (See SW1 Operation Table)

Test Mode

The control is placed in the test mode by holding the push button switch SW1 for 2 - 5 seconds. In test mode most of the control timings will be shortened by a factor of sixteen (16). LED3 (green) will flash at 1 second on and 1 second off. Additionally, when entering test mode LED1 (red) will flash the last lockout one time. Test mode will automatically time out after 30 minutes. Test mode can be exited by pressing and holding the SW1 button for 2 to 5 seconds or by cycling the power. **NOTE:** Test mode will automatically be exited after 30 minutes.

Reset Configuration Mode

The control is placed in reset configuration mode by holding the push button switch SW1 for 50 to 60 seconds. This will reset all configuration settings and the EEPROM back to the factory default settings. LED3 (green) will turn off when entering reset configuration mode. Once LED3 (green) turns off, release SW1 and the control will reset.

DIP Switch (SW2)

SW2-1 (Source) FP1 Selection – Low water coil temperature limit setting for freeze detection. On = 30°F; Off = 15°F.

SW2-2 (Load) FP2 Selection – On = 30°F; Off = 15°F

SW2-3 RV – O/B - thermostat type. Heat pump thermostats with “O” output in cooling or “B” output in Heating can be selected. On = O; Off = B.

SW2-4 Access Relay Operation (P2) and 2-5

Access Relay Operation	SW2-4	SW2-5
Cycle with Blower		n/a
Cycle with Compressor	OFF	OFF
Water Valve Slow Opening	ON	OFF
Cycle with Comm. T-stat Hum Cmd		n/a

Cycle with Blower - (Not used on water-to-water)

Cycle with Compressor - The accessory relay will cycle with the compressor output.

Water Valve Slow Opening - The accessory relay will cycle and delay both the blower and compressor output for 90 seconds.

SW2-6 CC Operation – selection of single or dual capacity compressor. On = Single Stage; Off = Dual Capacity

SW2-7 Lockout and Alarm Outputs (P2) – selection of a continuous or pulsed output for both the LO and ALM Outputs. On = Continuous; Off = Pulsed

SW2-8 Future Use

Alarm Jumper Clip Selection

From the factory, ALM is connected to 24 VAC via JW2. By cutting JW2, ALM becomes a dry contact connected to ALG.

Field Selectable Options via Software

(Selectable via the Aurora AID Tool)

Safety Features

The following safety features are provided to protect the compressor, heat exchangers, wiring and other components from damage caused by operation outside of design conditions.

Fuse – a 3 amp automotive type plug-in fuse provides protection against short circuit or overload conditions.

Anti-Short Cycle Protection – 4 minute anti-short cycle protection for the compressor.

Random Start – 5 to 80 second random start upon power up.

The Aurora Base Control System cont.

Fault Retry - in the fault condition, the control will stage off the outputs and then “try again” to satisfy the thermostat Y input call. Once the thermostat input calls are satisfied, the control will continue on as if no fault occurred. If 3 consecutive faults occur without satisfying the thermostat Y input call, then the control will go to Lockout mode.

Lockout - The Alarm output (ALM) and Lockout output (L) will be turned on. The fault type identification display LED1 (Red) shall flash the fault code. To reset lockout conditions with SW2-8 On, thermostat inputs “Y1”, “Y2”, and “W” must be removed for at least 3 seconds. To reset lockout conditions with SW2-8 Off, thermostat inputs “Y1”, “Y2”, “W”, and “DH” must be removed for at least 3 seconds. Lockout may also be reset by turning power off for at least 30 seconds or by enabling the emergency shutdown input for at least 3 seconds.

High Pressure - fault is recognized when the Normally Closed High Pressure Switch, P4-9/10 opens, no matter how momentarily. The High Pressure Switch is electrically in series with the Compressor Contactor and serves as a hard-wired limit switch if an overpressure condition should occur.

Low Pressure - fault is recognized when the Normally Closed Low Pressure Switch, P4-7/8 is continuously open for 30 seconds. Closure of the LPS any time during the 30 second recognition time restarts the 30 second continuous open requirement. A continuously open LPS shall not be recognized during the 2 minute startup bypass time.

Loss of Charge - fault is recognized when the Normally Closed Low Pressure Switch, P4-7/8 is open prior to the compressor starting.

Freeze Detection (Source Coax) - set points shall be either 30°F or 15°F. When the thermistor temperature drops below the selected set point, the control shall begin counting down the 30 seconds delay. If the thermistor value rises above the selected set point, then the count should reset. The resistance value must remain below the selected set point for the entire length of the appropriate delay to be recognized as a fault. This fault will be ignored for the initial 2 minutes of the compressor run time.

Freeze Detection (Load Coax) - uses the FP2 input to protect against ice formation on the coax. The FP2 input will operate exactly like FP1.

Over/Under Voltage Shutdown - An over/under voltage condition exists when the control voltage is outside the range of 18 VAC to 30 VAC. If the over/under voltage shutdown lasts for 15 minutes, the lockout and alarm relay will be energized. Over/under voltage shutdown is self-resetting in that if the voltage comes back within range of 18 VAC to 30 VAC for at least 0.5 seconds, then normal operation is restored.

Operation Description

Power Up - The unit will not operate until all the inputs and safety controls are checked for normal conditions. The unit has a 5 to 80 second random start delay at power up. Then the compressor has a 4 minute anti-short cycle delay after the random start delay.

Standby In standby mode, Y1, Y2, W, DH, and G are not active. Input O may be active. The compressor will be off.

Heating Operation

Heating, 1st Stage (Y1) - The compressor is energized 10 seconds after the Y1 input is received.

Cooling Operation

In all cooling operations, the reversing valve directly tracks the O input. Thus, anytime the O input is present, the reversing valve will be energized.

Cooling, 1st Stage (Y1, O) - The compressor is energized 10 seconds after the Y1 input is received.

Emergency Shutdown - Four (4) seconds after a valid ES input, P2-7 is present, all control outputs will be turned off and remain off until the emergency shutdown input is no longer present. The first time that the compressor is started after the control exits the emergency shutdown mode, there will be an anti-short cycle delay followed by a random start delay. Input must be tied to common to activate.

Load Shed - The LS input disables all outputs with the exception of the blower output. When the LS input has been cleared, the anti-short cycle timer and random start timer will be initiated. Input must be tied to common to activate.

The Aurora Base Control System cont.

Aurora 'Base' Control LED Displays

These three LEDs display the status, configuration, and fault codes for the control. These can also be read in plain English via the Aurora AID Tool.

Status LED (LED3, Green)

Description of Operation	Fault LED, Green
Normal Mode	ON
Control is Non-functional	OFF
Test Mode	Slow Flash
Lockout Active	Fast Flash
Dehumidification Mode	Flash Code 2
(Future Use)	Flash Code 3
(Future Use)	Flash Code 4
Load Shed	Flash Code 5
ESD	Flash Code 6
(Future Use)	Flash Code 7

Fault LED (LED1, Red)

Red Fault LED		LED Flash Code*	Lockout	Reset/Remove
ABC Basic Faults	Normal - No Faults	OFF	-	
	Fault - Input	1	No	Auto
	Fault - High Pressure	2	Yes	Hard or Soft
	Fault - Low Pressure	3	Yes	Hard or Soft
	Fault - Freeze Detection FP2	4	Yes	Hard or Soft
	Fault - Freeze Detection FP1	5	Yes	Hard or Soft
	Fault - Condensate Overflow	7	Yes	Hard or Soft
	Fault - Over/Under Voltage	8	No	Auto
	Fault - FP1 & FP2 Sensor Error	11	Yes	Hard or Soft

NOTE: All codes >11 use long flash for tens digit and short flash for the ones digit. 20, 30, 40, 50, etc. are skipped.

ABC Control Board Layout

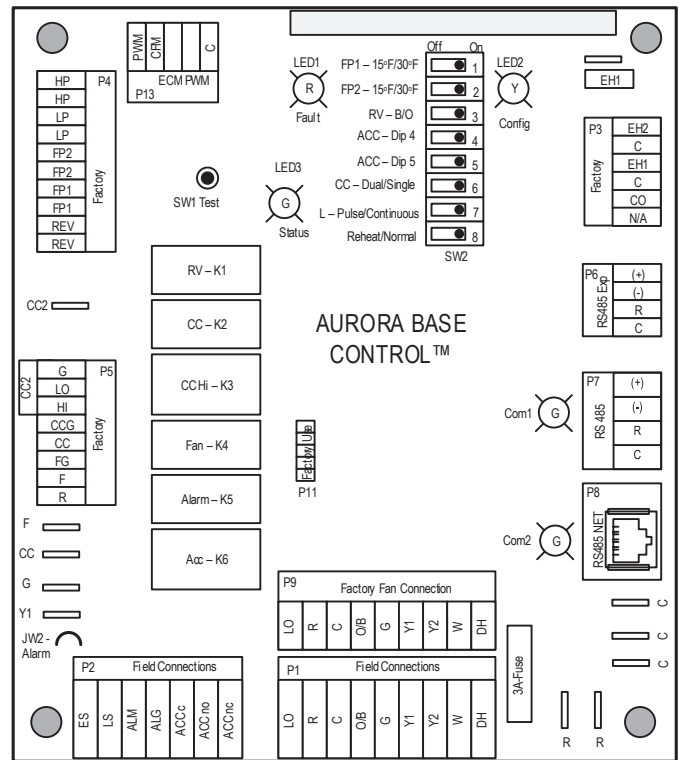

Aurora Interface and Diagnostics (AID) Tool

The Aurora Interface and Diagnostics (AID) Tool is a device that is a member of the Aurora network. The AID Tool is used to troubleshoot equipment which uses the Aurora control via Modbus RTU communication. The AID Tool provides diagnostics, fault management, ECM setup, and system configuration capabilities to the Aurora family of controls. An AID Tool is recommended, although not required, for ECM airflow settings. The AID Tool simply plugs into the exterior of the cabinet in the AID Tool port.



The Aurora Base Control System cont.

Aurora ‘Advanced’ Control Features

The Aurora ‘Advanced’ Control system expands on the capability of the Aurora ‘Base’ Control (ABC) by adding the Aurora Expansion Board (AXB). All of the preceding features of the Aurora ‘Base’ Control are included. The following control description is of the additional features and capability of the Aurora advanced control.

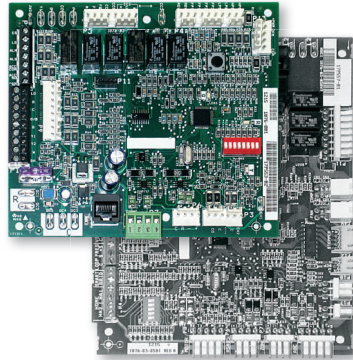

It is highly recommended the installing/servicing contractor obtain an Aurora Interface and Diagnostic Tool (AID) and specialized training before attempting to install or service an Aurora ‘Advanced’ control system.



The additional AXB features include the following:

AXB DIP Switch

DIP 1 - ID: This is the AXB ModBus ID and should always read On.

DIP 2 & 3 - Future Use

DIP 4 & 5 - Accessory Relay2: A second, DIP configurable, accessory relay is provided that can be cycled with the compressor 1 or 2, blower, or the Dehumidifier (DH) input. This is to complement the Accessory 1 Relay on the ABC board.

Position	DIP 4	DIP 5	Description
1	ON	ON	Cycles with Fan or ECM (or G)
2	OFF	ON	Cycles with CC1 first stage of compressor or compressor spd 6
3	ON	OFF	Cycles with CC2 second stage of compressor or compressor spd 7-12
4	OFF	OFF	Cycles with DH input from ABC board

Compressor Monitoring

The AXB includes two current transducers to monitor the compressor current and starting characteristics. Open circuits or welded contactor faults will be detected. A fault will produce an E10 code.

Advanced Communication Ports

Communication ports P6 and P8 will provide future expansion via dedicated protocols. These are for future use.

The Aurora Base Control System cont.

Smart Grid-On Peak (SG) Input

The 'On Peak' input was designed to allow utilities to utilize simple radio controlled switches to control the On Electric Peak behavior of the 5 and 7 Series Geothermal Heat Pumps. With a closed contact signal, this input will limit the operation and thus the power consumption of the unit by one of the below selections. The AID Tool will allow configuration of this input for the action of:

- No Action
- Disable compressor operation until removed
- Go to On Peak thermostat settings until removed [Requires Com T-Stat] (Future Release)
- Compressor limited to 50% or low cap until removed [dual capacity or variable speed only] (Future Release)
- Disable compressor operation for 1/2 hr (can be removed immediately) (Future Release)

Then Flash Code 7 on the Green LED for the 'On Peak' mode. And On Peak will display on communicating thermostats.

Monitoring Sensor Kits

Energy Monitoring (Standard Sensor Kit)

The Energy Monitoring Kit includes four current transducers (source pump, load pump, auxiliary heat 1 and auxiliary heat 2) added to the existing four compressor sensors for compressor A and compressor B so that the complete power usage of the heat pump can be measured. The AID Tool provides a line voltage calibration procedure to improve the accuracy, and a power adjustment setting that allows the compressor power to be adjusted to match the units line voltage using the provided tables. This information can be displayed on the AID Tool.

Refrigerant Monitoring

The Refrigerant Monitoring Kit includes two pressure transducers, and three temperature sensors, heating liquid line, suction temperature and existing cooling liquid line (FPI). These sensors allow the measurement of discharge and suction pressures, suction and liquid line temperatures as well as superheat and subcooling. This information will only be displayed on the AID Tool.

Performance Monitoring

The Performance Monitoring Kit includes three temperature sensors, entering and leaving source, and leaving load water.

The Aurora Base Control System cont.

Aurora 'Advanced' Control LED Displays

These three LEDs display the status, configuration, and fault codes for the control. These can also be read in plain English via the Aurora AID Tool.

Status LED (LED3, Green)

Description of Operation	Fault LED, Green
Normal Mode	ON
Control is Non-functional	OFF
Test Mode	Slow Flash
Lockout Active	Fast Flash
Dehumidification Mode	Flash Code 2
Load Shed	Flash Code 5
Emergency Shutdown	Flash Code 6
On Peak Mode	Flash Code 7
(Future Use)	Flash Code 8
(Future Use)	Flash Code 9

Configuration LED (LED2, Yellow)

Description of Operation	Configuration LED, Yellow
No Software Overwritten	ECM Setting
DIP Switch Overwritten	Slow Flash
ECM Configuration Mode	Fast Flash
Reset Configuration Mode	OFF

Fault LED (LED1, Red)

Red Fault LED	LED Flash Code *	Lockout	Reset/Remove	Fault Condition Summary	
Normal - No Faults	Off	-			
ABC Basic Faults	Fault-Input	1	No	Auto	Tstat input error. Autoreset upon condition removal.
	Fault-High Pressure	2	Yes	Hard or Soft	HP switch has tripped (>600 psi)
	Fault-Low Pressure	3	Yes	Hard or Soft	Low Pressure Switch has tripped (<40 psi for 30 continuous sec.)
	Fault-Freeze Detection FP2	4	Yes	Hard or Soft	Freeze protection sensor has tripped (<15 or 30 degF for 30 continuous sec.)
	Fault-Freeze Detection FP1	5	Yes	Hard or Soft	Freeze protection sensor has tripped (<15 or 30 degF for 30 continuous sec.)
	Fault-Condensate Overflow	7	Yes	Hard or Soft	Condensate switch has shown continuity for 30 continuous sec.
	Fault-Over/Under Voltage	8	No	Auto	Instantaneous voltage is out of range. **Controls shut down until resolved.
Fault-FP1 Snsr Error	11	Yes	Hard or Soft	If FP1 Sensor Error	
ABC & AXB Advanced Faults	Fault-Compressor Monitor	10	Yes	Hard or Soft	Open Crkt, Run, Start or welded cont
	Non-CriticAXBSnsrErr	13	No	Auto	Any Other Sensor Error
	CriticAXBSnsrErr	14	Yes	Hard or Soft	Sensor Error for EEV or HW
	Alert-HotWtr	15	No	Auto	HW over limit or logic lockout. HW pump deactivated.
	Fault-VarSpdPump	16	No	Auto	Alert is read from PWM feedback.
	Not Used	17	No	Auto	IZ2 Com Fault. Autoreset upon condition removal.
	Non-CritComErr	18	No	Auto	Any non-critical com error
	Fault-CritComErr	19	No	Auto	Any critical com error. Auto reset upon condition removal
	Alarm - Low Loop Pressure	21	No	Auto	Loop pressure is below 3 psi for more than 3 minutes
	Alarm - Home Automation 1	23	No	Auto	Closed contact input is present on Dig 2 input - Text is configurable
Alarm - Home Automation 2	24	No	Auto	Closed contact input is present on Dig 3 input - Text is configurable	

NOTES:

*All codes >11 use long flash for tens digit and short flash for the ones digit. 20, 30, 40, 50 etc. are skipped!

Alert' is a noncritical sensor or function that has failed. Normal operation of the heat pump is maintained but service is desired at some point.

Two-Stage Hydronic Application Notes

The Closed Loop Heat Pump Concept

The basic principle of a water source heat pump is the transfer of heat into water from the space during cooling, or the transfer of heat from water into the space during heating. Extremely high levels of energy efficiency are achieved as electricity is used only to move heat, not to produce it. Using a typical Two-Stage Hydronic unit, one unit of electricity will move four to five units of heat.

When multiple water source heat pumps are combined on a common circulating loop, the ultimate in energy efficiency is created: The units on cooling mode are adding heat to the loop which the units in heating mode can absorb, thus removing heat from the area where cooling is needed, recovering and redistributing that heat for possible utilization elsewhere in the system. In modern commercial structures, this characteristic of heat recovery from core area heat generated by lighting, office equipment, computers, solar radiation, people or other sources, is an important factor in the high efficiency and low operating costs of closed source heat pump systems.

In the event that a building's net heating and cooling

needed basis"- perfect for speculative buildings. Installed costs are low since units are self-contained and can be located adjacent to the occupied space, requiring minimal ductwork. Maintenance can be done on individual units without system shut-down. Conditions remain comfortable since each unit operates separately, allowing cooling in one area and heating in another. Tenant spaces can be finished and added as needed. Power billing to tenants is also convenient since each unit can be individually metered: each pays for what each uses. Nighttime and/or weekend uses of certain areas are possible without heating or cooling the entire facility. A decentralized system also means if one unit should fault, the rest of the system will continue to operate normally, as well as eliminating air cross-contamination problems and expensive high pressure duct systems requiring an inefficient electric resistance reheat mode.

The Two-Stage Hydronic Approach

There are a number of proven choices in the type of Two-Stage Hydronic Series system which would be best for any given application. Most often considered are:

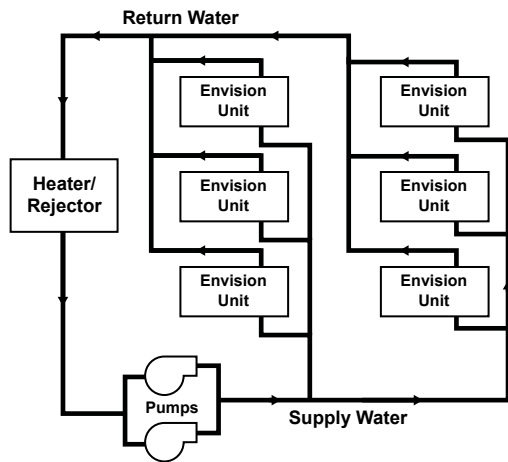

requirements create loop temperature extremes, Two-Stage Hydronic Series units have the extended range capacity and versatility to maintain a comfortable environment for all building areas. Excess heat can be stored for later utilization or be added or removed in one of three ways; by ground-source heat exchanger loops: plate heat exchangers connected to other water sources, or conventional cooler/boiler configurations. Your representative has the expertise and computer software to assist in determining optimum system type for specific applications.

The Closed Loop Advantage

A properly applied water source heat pump system offers many advantages over other systems. First costs are low because units can be added to the loop on an "as

Closed Loop/Ground Source Vertical

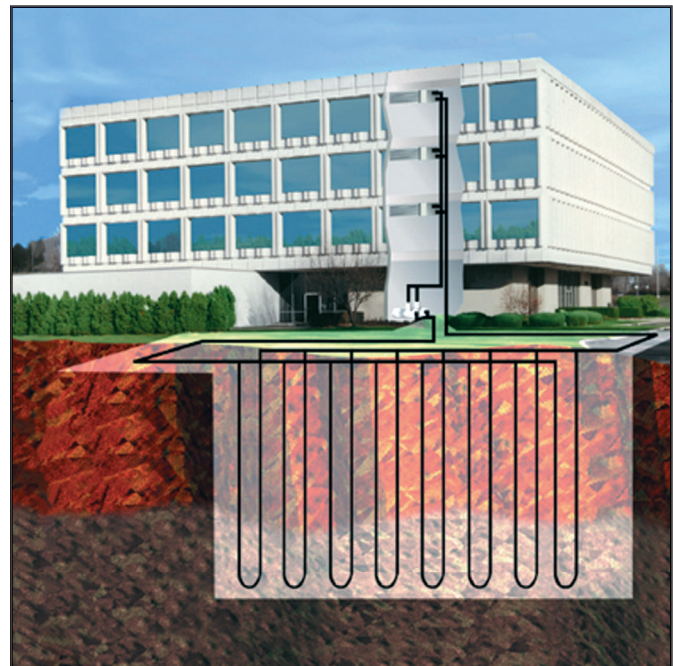

- **Closed Loop/Ground-Source Systems** utilize the stable temperatures of the earth to maintain proper water source temperatures (via vertical or horizontal closed loop heat exchangers) for Two-Stage Hydronic Series extended range heat pump system. Sizes range from a single unit through many hundreds of units. When net cooling

Two-Stage Hydronic Application Notes cont.

requirements cause closed loop water temperatures to rise, heat is dissipated into the cooler earth through buried high strength plastic pipe "heat exchangers." Conversely if net space heating demands cause loop heat absorption beyond that heat recovered from building core areas, the loop temperature will fall causing heat to be extracted from the earth. Due to the extended loop temperatures, AHRI/ISO 13256-1 Ground Loop Heat Pumps are required for this application.

Because auxiliary equipment such as a fossil fuel boiler and cooling tower are not required to maintain the loop temperature, operating and maintenance costs are very low. Ground-source systems are most applicable in residential and light commercial buildings where both heating and cooling are desired, and on larger envelope dominated structures where core heat recovery will not meet overall heating loads. Both vertical and horizontally installed closed-loops can be used. The land space required for the "heat exchangers" is 100-250 sq. ft./ton on vertical (drilled) installations and 750-1500 sq. ft./ton for horizontal (trenched) installations. Closed loop heat exchangers can be located under parking areas or even under the building itself.

On large multi-unit systems, sizing the closed loop heat exchanger to meet only the net heating loads and assisting in the summer with a closed circuit cooling tower may be the most cost effective choice.

Closed Loop/Ground Source Surface Water

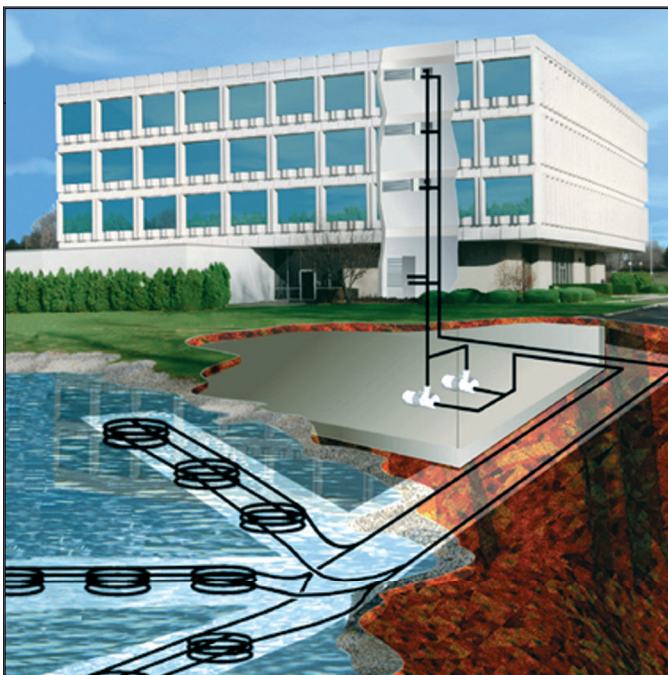

• ***Closed Loop/Ground-Source Surface Water Systems*** also utilize the stable temperatures of Surface Water to maintain

proper water source temperatures for Two-Stage Hydronic Series extended range heat pump systems. These systems have all of the advantages of horizontal and vertical closed loop systems. Due to the extended loop temperatures, AHRI/ISO 13256-1 Ground Water or Ground Loop Heat Pumps are required for this application.

In cooling dominated structures, the ground-source surface water systems can be very cost effective especially where local building codes require water retention ponds for short term storage of surface run-off. Sizing requirements for the surface water is a minimum of 500 sq. ft./ton of surface area at a minimum depth of 8 feet. WaterFumace should be contacted when designs for heating dominated structures are required.

Closed Loop/Ground Water Plate Heat Exchanger

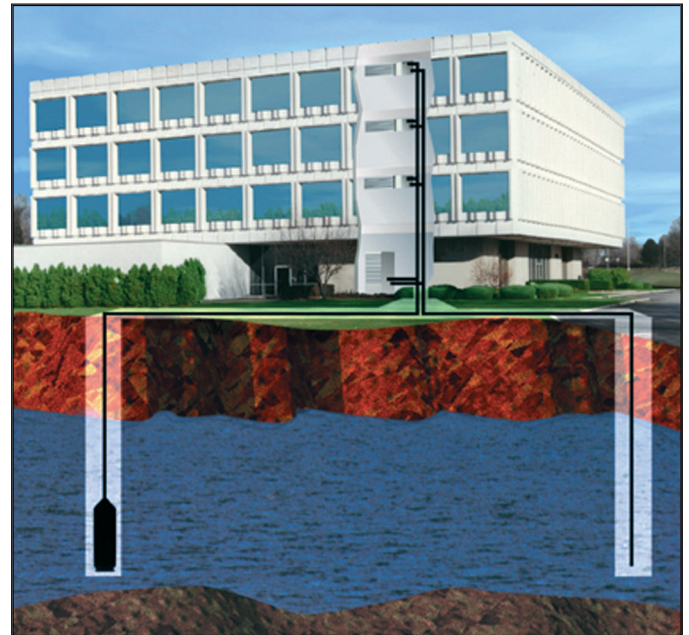

• ***Closed Loop/Ground Water Plate Heat Exchanger Systems*** utilize lake, ocean, well water or other water sources to maintain closed loop water temperatures in multi-unit Two-Stage Hydronic systems. A plate frame heat exchanger isolates the units from any contaminating effects of the water source, and allows periodic cleaning of the heat exchanger during off peak hours.

Operation and benefits are similar to those for ground-source systems. Due to the extended loop temperatures, AHRI/ISO 13256-1 Ground Loop Heat Pumps are required for this application. Closed loop plate heat exchanger systems are applicable in commercial, marine, or industrial structures where the many benefits of a water source heat pump system are desired, regardless of whether the load is heating or cooling dominated.

Two-Stage Hydronic Application Notes cont.

Closed Loop Cooler - Boiler

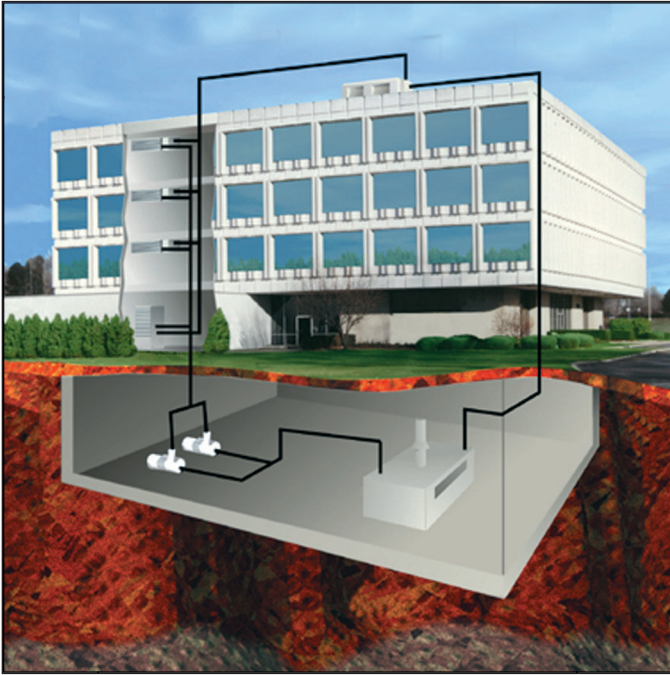

- ***Closed Loop /Cooler-Boiler Systems*** utilize a closed heat recovering loop with multiple water source heat pumps in the more conventional manner. Typically a boiler is employed to maintain closed loop temperatures above 60°F and a cooling tower to maintain loop temperatures below 90°F. These systems are applicable in medium to large buildings regardless of whether the load is heating or cooling dominated. Due to the moderate loop temperatures, AHRI/ISO 13256-1 Water Loop Heat Pumps are required for this application.

Two-Stage Hydronic Application Notes cont.

Heating with hot water is versatile because there are many ways of distributing the heat through the building. The options range from heavy cast iron radiators seen in older buildings to modern, baseboard-style convection radiation, and from invisible radiant floor heating to forced air systems using fan coil units.

A boiler is often used to make domestic hot water and to heat swimming pools or hot tubs.

The various distribution systems have all been used successfully with a geothermal heat pump system. When designing or retrofitting an existing hydronic heating system, however, the water temperature produced by the heat pump is a major consideration.

In general, heat pumps are not designed to produce water above 130°F. The efficiency decreases as the temperature difference (ΔT) between the heat load (generally the earth loop) and the supply water (to the distribution system) increases. Figure 1 illustrates the effect of source and load temperatures on the system. The heating capacity of the heat pump also decreases as the temperature difference increases.

When using the various types of hydronic heat distribution systems, the temperature limits of the geothermal system must be considered. In new construction, the distribution system can easily be designed with the temperature limits in mind. In retrofits, care must be taken to address the operating temperature limits of the existing distribution system.

Figure 1: As the ΔT increases, the Coefficient of Performance (COP) decreases. When the system produces 130°F water from a 30°F earth loop, the ΔT is 100°F, and the COP is approximately 2.5. If the system is producing water at 90°F, the ΔT is 60°F and the COP rises to about 3.8, an increase of over 50%.

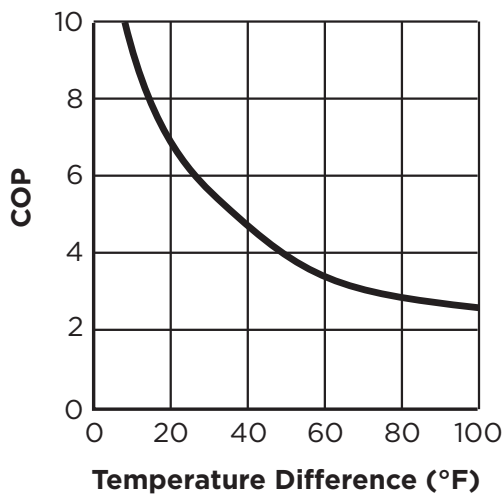

Baseboard Radiation

In existing systems, baseboard radiation is typically designed to operate with 160° to 240°F water or steam. Baseboard units are typically copper pipe with aluminum fins along the length of the pipe, as shown in Figure 2. A decorative cover is normally fitted over the fin tube.

The operation of a baseboard radiation system depends on setting up a convection current in the room: air is warmed by the fin tube, rises and is displaced by cool air.

The heating capacity of a baseboard system is a factor of the area of copper tube and fins exposed to the air and the temperature difference between the air and the fin tube. The velocity and volume of water flowing through the baseboard affects the temperature of the copper and fins. Baseboard units are normally rated in heat output/length of baseboard at a standard water temperature and flow. Manufacturers can provide charts which will give the capacities at temperatures and flows below the standard. Figure 3 shows approximate heating capacities for fin tube radiation using water from 100 to 130°F water.

Baseboards are available using two or three fin tubes tiered above one another in the same cabinet. With the additional surface area, the air can be heated enough to set up a convection current with water temperatures as low as 110° to 130°F (see Figure 3).

It is important to ensure that the heat output of the system is adequate to meet the heat loss of the room or building at the temperatures the geothermal system is capable of producing.

Baseboard radiation is limited to space heating. Cooling is typically provided by a separate, forced air distribution system.

Figure 2: Baseboard radiators are typically constructed of copper tube with closely spaced aluminum fins attached to provide more surface area to dissipate heat. Some of the factors affecting the amount of heat given off by fin tube radiators are the water temperature, water velocity, air temperature, and fin spacing and size.

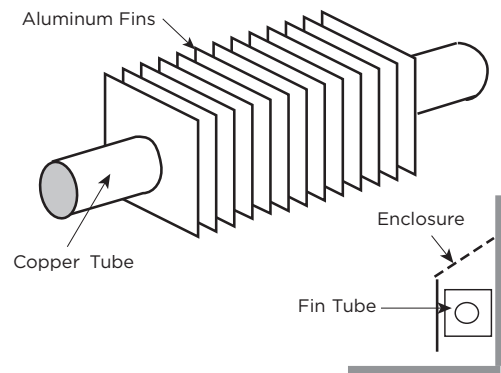

Two-Stage Hydronic Application Notes cont.

The heating capacity (Btuh/linear foot) of baseboard radiators drop as the water temperature is reduced. The heating capacity of most baseboard radiators is rated using 200°F water, 65°F air temperature. Listed in Figure 3 is the range of heating capacities of baseboard radiators at the standard temperatures and the range of capacities when the temperatures are reduced to the operating range of a heat pump system. Some of the factors that affect the capacity of a radiator are:

- Size of the fins - range from 2.75 in. x 3 in. to 4 in. x 4 in.
- Fin spacing - 24 to 48/foot
- Diameter of copper tube - range from .75 in. to 2 in.
- Fin material - aluminum or steel
- Configuration and height of the enclosure
- Height unit is mounted from the floor
- Water flow through the radiator

Generally, the smaller fins with fewer fins/foot will have lower heating capacity. Larger copper tube diameter and aluminum fins will have a higher capacity. Higher water flow will increase capacity. Adding a second fin tube to the same enclosure will increase the capacity by 50 to 60%. Adding two fin tubes will increase the capacity by 75 to 80%.

Figure 3: Heating output per linear foot

Average Water Temp.	Entering Air Temperatures		
	55°F	65°F	70°F
110°F	190-380	160-320	150-300
120°F	240-480	205-410	195-390
130°F	295-590	265-532	245-490

Cast Iron Radiation

Retrofit applications for hydronic/geothermal heat pump systems are often required to work with existing cast iron radiators or their replacements (see Figure 4). Typically, cast iron radiator systems operate with water temperatures of 125° to 160°F.

These temperatures are higher than geothermal water-to-water heat pumps are capable of providing. Cast iron radiators can work with geothermal systems, provided the heat output of the radiators will meet the maximum heat loss of the building at the lower temperatures.

If the insulation of the building has been upgraded since the original installation, it is possible that the lower temperatures will be able to meet the reduced heat loss of the building.

Figure 4: Baseboard System

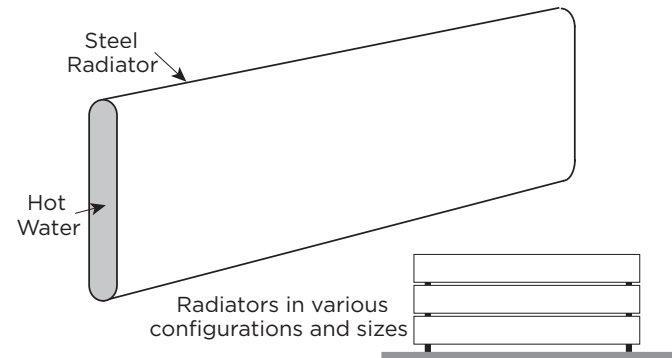

Radiant Floor Heating

Radiant floor heating has been the system of choice in many parts of Europe for some time. Manufacturers have developed tubing designed for installation in concrete floors and raised wood floors.

Floor heating systems have several benefits in residential, commercial and industrial heating applications. In a building with a radiant floor heating system, the entire floor acts as a heat source for the room. People feel comfortable with lower air temperatures if their feet are warm. Typically the space will feel comfortable with air temperatures as low as 65°F. Since the heat loss of a building is directly related to the temperature difference (ΔT) between the inside and outside, a lower ΔT means the heat loss is lower.

Air temperatures in a room with a forced air heating system tend to be warmer nearer to the ceiling than the floor (see Figure 5). The hot air rises and creates a greater pressure imbalance between the inside and outside. The infiltration increases, resulting in a higher heat loss. Air temperatures in a room with radiant floor heating tend to be warmer at the floor than the ceiling, helping to cut down on infiltration in the building. The energy savings in a building with radiant floor heating can range from 10 to 20%.

Figure 5: Temperature Comparison

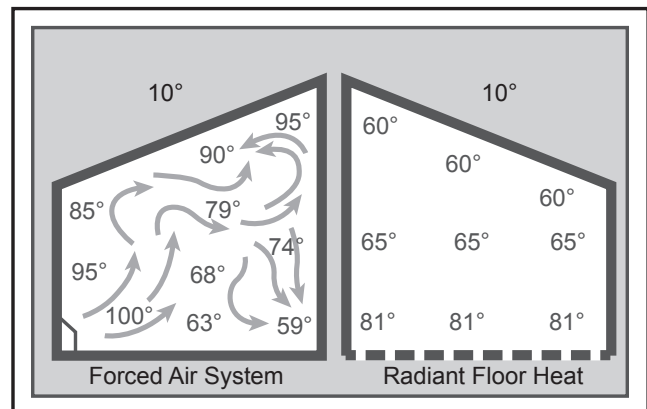

Two-Stage Hydronic Application Notes cont.

A floor heat system can be designed to heat a building with water temperatures as low as 90°F.

Figure 1 shows how a geothermal system operates more efficiently with a lower ΔT between the source and the load. With only a 60°F temperature difference, a geothermal heat pump will operate at COPs over 4, about 20% higher than a forced air geothermal system in the same installation.

Some of the factors affecting the heating capacity of a floor heating system are as follows:

- The type of finish flooring
- The spacing of the pipe
- The water flow through the pipe
- The temperature of the supply water
- The floor material (wood, concrete or poured Gypcrete™)
- Insulation value under the floor
- The piping layout

The spacing of the pipe in residential applications can vary from 4 in. to 12 in. If the spacing is too large, the temperature of the floor can vary noticeably. In industrial applications, variation in the floor temperature is not as important, and the spacing is related directly to the heat output required.

Radiant floor heating systems work well with geothermal heat pump systems. For efficient operation, the system must be designed with the lowest possible water temperatures.

There are some drawbacks with a radiant floor heating system. Air conditioning is only possible by adding a second system using forced air. This can add substantial cost to an installation where air conditioning is also needed. A separate air handling system is needed to clean the air or to introduce fresh air.

Industrial buildings, especially those with high ceilings and large overhead doors, have an advantage with a radiant floor heating system. Heat is stored in the concrete floor, and when a door is opened, the stored heat is immediately released to the space. The larger the ΔT between the air in the space and the floor, the quicker the floor releases its heat to the space.

Maintenance garages benefit from radiant floor heating systems. Cold vehicles brought into the garage are warmed from underneath. The snow melts off the vehicle and dries much more quickly than when heated from above.

Some pipe manufacturers include an oxygen diffusion barrier in the pipe to prevent oxygen diffusion through the pipe. Good system design and careful installation, however, will eliminate virtually all of the problems encountered with air in the system. Like earth loop design, it is important to design the system to facilitate flushing the air initially and ensuring that the flows can be balanced properly.

Fan Coil Units and Air Handlers

Fan coil units, air handlers, force flow units, etc. are all basically a hot water radiator or coil (usually copper piping with aluminum fins) with a fan or blower to move the air over the coil (see Figure 6). The term “fan coil units” typically applies to smaller units that are installed in the zone or area in which heating (or cooling) is needed. They are available in many different configurations, sizes and capacities. Fan coil units are designed to be connected to a ductwork system and can be used to replace a forced air furnace. Other units are designed for use without ductwork and are mounted in a suspended ceiling space with only a grill showing in place of a ceiling tile. Some can be mounted on a wall under a window, projecting 8 in. to 10 in. into the room or even flush to the wall surface, mounted between wall studs. Some are available with or without finished, decorative cabinets. For industrial applications, inexpensive “unit heaters” are available, with only a coil and an axial fan. Fan coil units and unit heaters are normally available with air handling capacities of 200 to 2,000 cfm.

The term “air handler” normally applies to larger units, mounted in mechanical rooms, mechanical crawl spaces or rooftops. They typically have an air handling capacity of over 2,000 cfm and are available for capacities of up to 50,000 cfm. Air handlers are typically built for a specific installation and are available with many different types of heating and cooling coils. They can include additional coils for heating make-up air, dehumidification and exhaust air heat recovery.

Fan coils and air handlers typically have one or two coils and a blower. Air is heated by hot water circulated through the hot water coil. Chilled water is circulated through the coil if air conditioning is needed. Blowers can be provided to fit various applications, with or without duct-work. Unit heaters typically use axial fans in applications where ductwork is not needed.

Fan coil units and air handlers are used in many different applications. They have been used to heat buildings using water temperatures as low as 90° to 100°F. New systems can be designed to operate very efficiently with a geothermal system.

Two-Stage Hydronic Application Notes cont.

Figure 6: Fan Coils

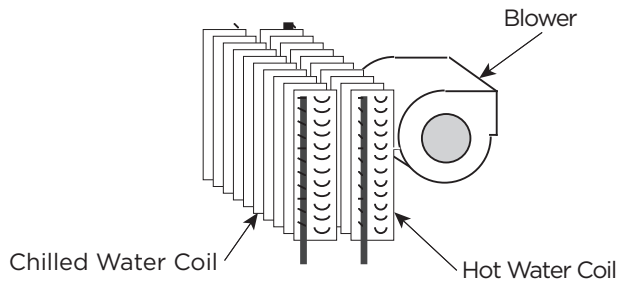

Cooling with a Hydronic System

Cooling a building with an existing radiant hydronic heating system can be a challenge. If baseboard, cast iron radiators or a radiant floor heating system is cooled lower than the dew point, condensation will form on the floor or drip off the radiators.

There is generally minimal or no ductwork for ventilation in existing buildings with radiant hydronic heat. Typically, cooling is provided with separate units where it is needed. This is often done using through-the-wall or window air conditioners, ductless split air conditioning units, or rooftop units.

A water-to-water heat pump system can provide water to ducted or unducted fan coil units. The system can provide chilled water to cool the building, as well as hot water for the heating system when needed.

A limited amount of cooling can be done by circulating chilled water through the piping in the floor. This can be effective in buildings with high solar loads or lighting loads, where much of the heat gain is radiant heat being absorbed by the floor. Cooling fresh air used for ventilation as it is brought into the building, using a chilled water coil, can sometimes provide the additional cooling needed. Care must be taken to avoid cooling the floor below the dew point because condensation may form on the floor.

Buildings with fan coil units and air handlers can generally be easily retrofitted for cooling. Often it is simply a matter of adding a cooling coil to the existing air handlers and fan coil units. Water-to-water heat pumps can provide hot water for the heating coils as well as chilled water for the air conditioning.

Controls

The control of a mechanical system determines how it functions. For the building to work efficiently and comfortably, the building owner or manager must understand what the system is doing and how to control it.

As Figure 1 shows, the efficiency of a heat pump is a factor of the difference in temperature between the source and the load. The heat loss or heat gain of a building varies with the weather and the use of the building. As the outdoor temperature decreases, the heat loss of the building increases. When the ventilation system is started up, the heating or cooling loads increase. As the occupancy increases, lighting or the solar gain increases, and the cooling load increases. At times the building may require virtually no heating or cooling.

With hydronic heating and cooling distribution equipment, whether it is baseboard radiation, fan coil units or radiant floor heating, the output of the equipment is directly related to the temperature and velocity of the water flowing through it. Baseboard radiation puts out approximately 50% less heat with 110°F water than with 130°F water. The same is true with fan coil units and radiant floor heating.

If a system is designed to meet the maximum heat loss of a building with 130°F water, it follows that if the heat loss is 50% lower when the outdoor temperature is higher and the building has high internal gains because of lighting and occupancy, the lower heat loss can be met with 110°F water. This greatly increases the COP of the heat pumps.

The same control strategy is equally effective in cooling. During peak loads, water chilled to 40°F may be needed; at other times 55°F water will provide adequate cooling. Significant increases in the EER can be achieved. Latent loads must always be considered when using warmer water.

Flow Rates

Load Flow Rate

The load flow on all water to water products including the Two-Stage Hydronic Series should be 3 gpm per ton (typically the rated flow and the highest flow shown in the capacity charts). Refer to the table below. This flow rate is required especially when heating water to limit the effects of the higher condensing temperatures of water heating for radiant floor heating or domestic water use.

	Source Flow Rate				Load Flow Rate
	Minimum Open Loop	Open Loop < 50°F	Closed Loop Range (Min - Full Flow)		
100	15	20	23	30	30
120	18	24	27	36	36
150	21	28	32	42	42
180	24	32	36	48	48

Source Flow Rate

The source flow can range between 2.25 and 3 gpm per ton for earth loops. For open loop well water systems the minimum flow should be 1.5 gpm per ton. In earth loop systems where entering water temperatures are expected to be above 95°F, 3 gpm per ton should be used. In well systems where the water temperature is below 50°F, 2 gpm per ton should be used to avoid nuisance freeze detection trips.

Water Quality

General

Two-Stage Hydronic systems may be successfully applied in a wide range of residential, commercial, and industrial applications. It is the responsibility of the system designer and installing contractor to ensure that acceptable water quality is present and that all applicable codes have been met in these installations.

Water Treatment

Do not use untreated or improperly treated water. Equipment damage may occur. The use of improperly treated or untreated water in this equipment may result in scaling, erosion, corrosion, algae or slime. The services of a qualified water treatment specialist should be engaged to determine what treatment, if any, is required. The product warranty specifically excludes liability for corrosion, erosion or deterioration of equipment.

The heat exchangers in the units are 316 stainless steel plates with copper brazing. The water piping in the heat exchanger is steel. There may be other materials in the building's piping system that the designer may need to take into consideration when deciding the parameters of the water quality.

If an antifreeze or water treatment solution is to be used, the designer should confirm it does not have a detrimental effect on the materials in the system.

Contaminated Water

In applications where the water quality cannot be held to prescribed limits, the use of a secondary or intermediate heat exchanger is recommended to separate the unit from the contaminated water.

Water Quality Guidelines

Material		Copper	90/10 Cupronickel	316 Stainless Steel
pH	Acidity/Alkalinity	7 - 9	7 - 9	7 - 9
Scaling	Calcium and Magnesium Carbonate	(Total Hardness) less than 350 ppm	(Total Hardness) less than 350 ppm	(Total Hardness) less than 350 ppm
Corrosion	Hydrogen Sulfide	Less than 0.5 ppm (rotten egg smell appears at 0.5 ppm)	10 - 50 ppm	Less than 1 ppm
	Sulfates	Less than 125 ppm	Less than 125 ppm	Less than 200 ppm
	Chlorine	Less than 0.5 ppm	Less than 0.5 ppm	Less than 0.5 ppm
	Chlorides	Less than 20 ppm	Less than 125 ppm	Less than 300 ppm
	Carbon Dioxide	Less than 50 ppm	10 - 50 ppm	10 - 50 ppm
	Ammonia	Less than 2 ppm	Less than 2 ppm	Less than 20 ppm
	Ammonia Chloride	Less than 0.5 ppm	Less than 0.5 ppm	Less than 0.5 ppm
	Ammonia Nitrate	Less than 0.5 ppm	Less than 0.5 ppm	Less than 0.5 ppm
	Ammonia Hydroxide	Less than 0.5 ppm	Less than 0.5 ppm	Less than 0.5 ppm
	Ammonia Sulfate	Less than 0.5 ppm	Less than 0.5 ppm	Less than 0.5 ppm
	Total Dissolved Solids (TDS)	Less than 1000 ppm	1000 - 1500 ppm	1000 - 1500 ppm
	LSI Index	+0.5 to -0.5	+0.5 to -0.5	+0.5 to -0.5
Iron Fouling (Biological Growth)	Iron, FE ²⁺ (Ferrous) Bacterial Iron Potential	< 0.2 ppm	< 0.2 ppm	< 0.2 ppm
	Iron Oxide	Less than 1 ppm, above this level deposition will occur	Less than 1 ppm, above this level deposition will occur	Less than 1 ppm, above this level deposition will occur
Erosion	Suspended Solids	Less than 10 ppm and filtered for max. of 600 micron size	Less than 10 ppm and filtered for max. of 600 micron size	Less than 10 ppm and filtered for max. of 600 micron size
	Threshold Velocity (Fresh Water)	< 6 ft/sec	< 6 ft/sec	< 6 ft/sec

NOTES: Grains = ppm divided by 17
mg/L is equivalent to ppm

2/22/12

The following table outlines the water quality guidelines for unit heat exchangers. If these conditions are exceeded, a secondary heat exchanger is required. Failure to supply a secondary heat exchanger where needed will result in a warranty exclusion for primary heat exchanger corrosion or failure.

Strainers

These units must have properly sized strainers upstream of both brazed plate heat exchangers to protect them against particles in the fluid. Failure to install proper strainers and perform regular service can result in serious damage to the unit, and cause degraded performance, reduced operating life and failed compressors. Improper installation of the unit (which includes not having proper strainers to protect the heat exchangers) can also result in voiding the warranty.

Field supplied strainers with 20-40 mesh (530-1060 microns) are recommended, with 30 mesh (800 microns) being the optimum choice. The strainers selected should have a mesh open area of at least 6 square inches (39 square centimeters) for each unit being serviced by the strainer. Using strainers with a smaller amount of open area will result in the need for more frequent cleaning.

Strainers should be selected on the basis of acceptable pressure drop, and not on pipe diameter. The strainers selected should have a pressure drop at the nominal flow rate of the units low enough to be within the pumping capacity of the pump being used.



WARNING: Must have intermediate heat exchanger when used in pool applications.

Two-Stage Hydronic Typical Application Piping

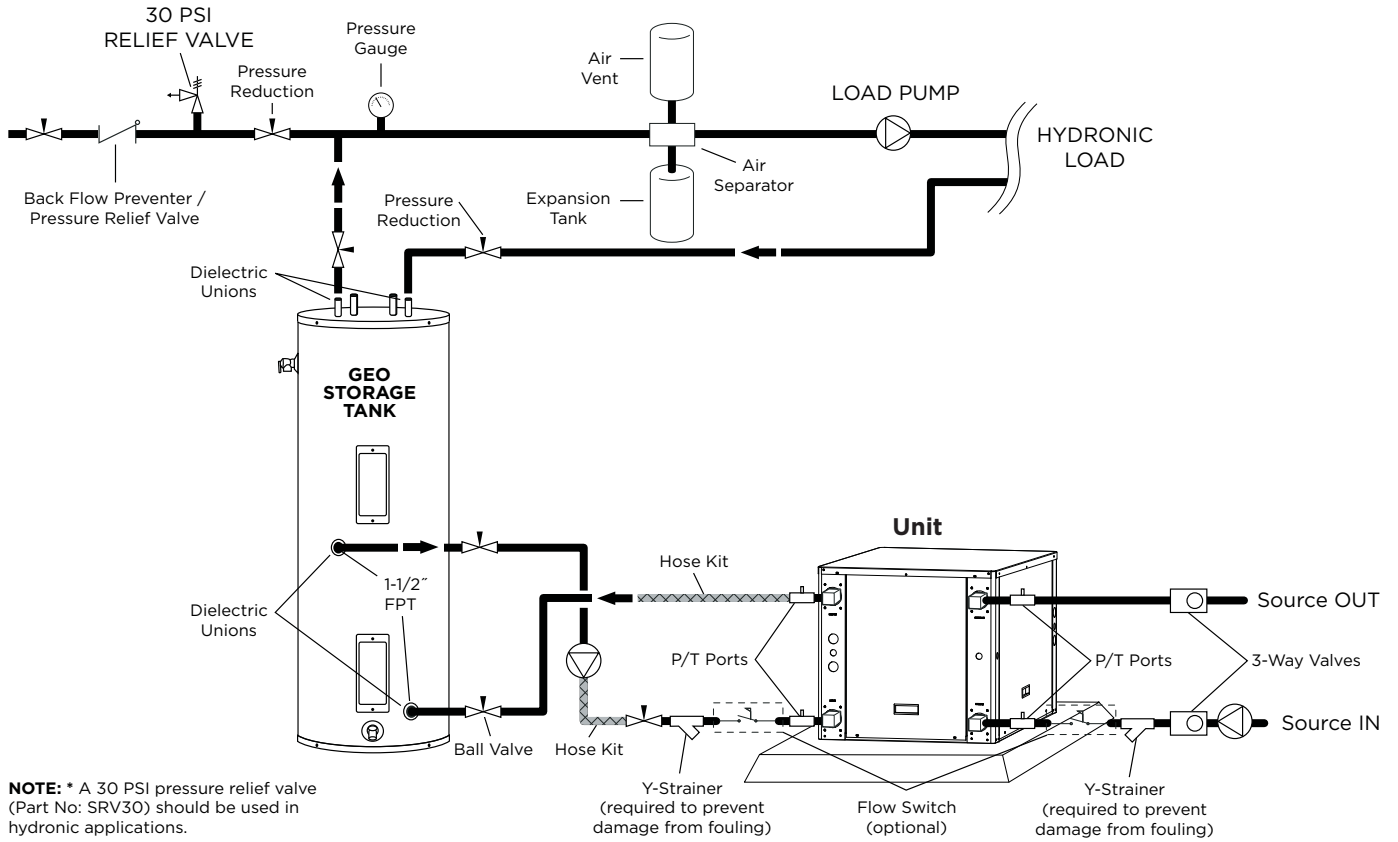

Dimensional Data

100-180 - Top Waterline Configuration

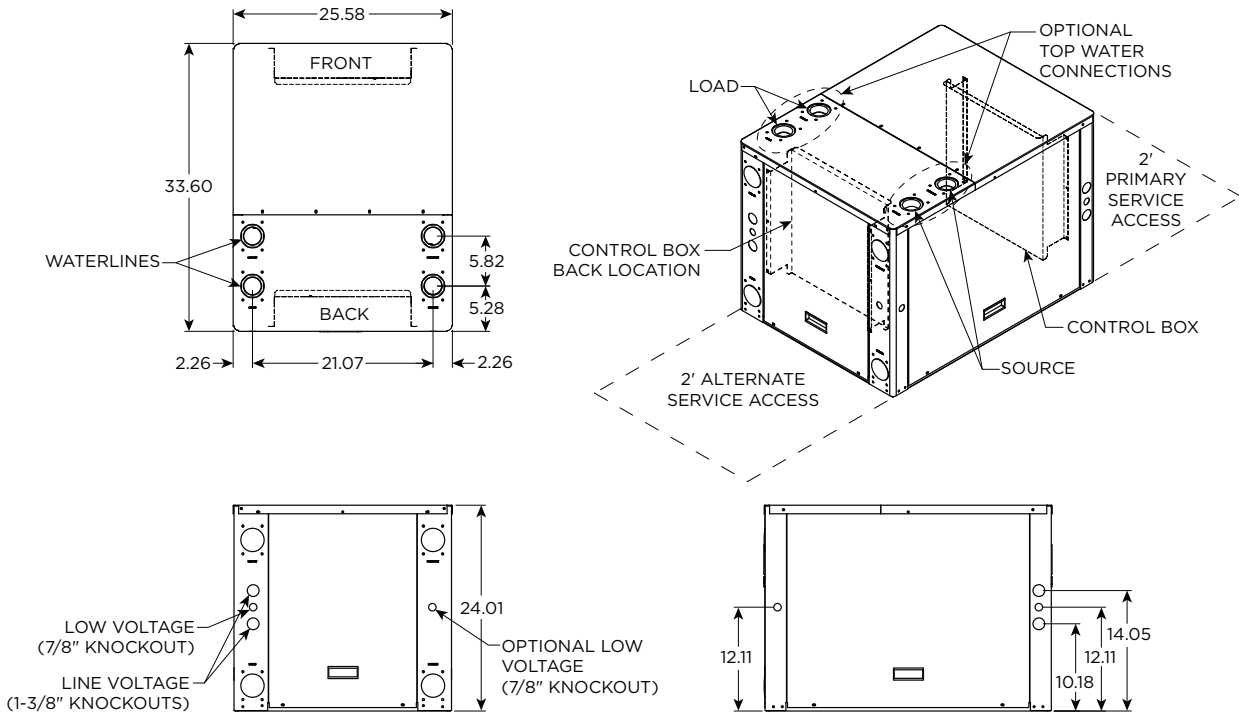

100-180 - Back Waterline Configuration

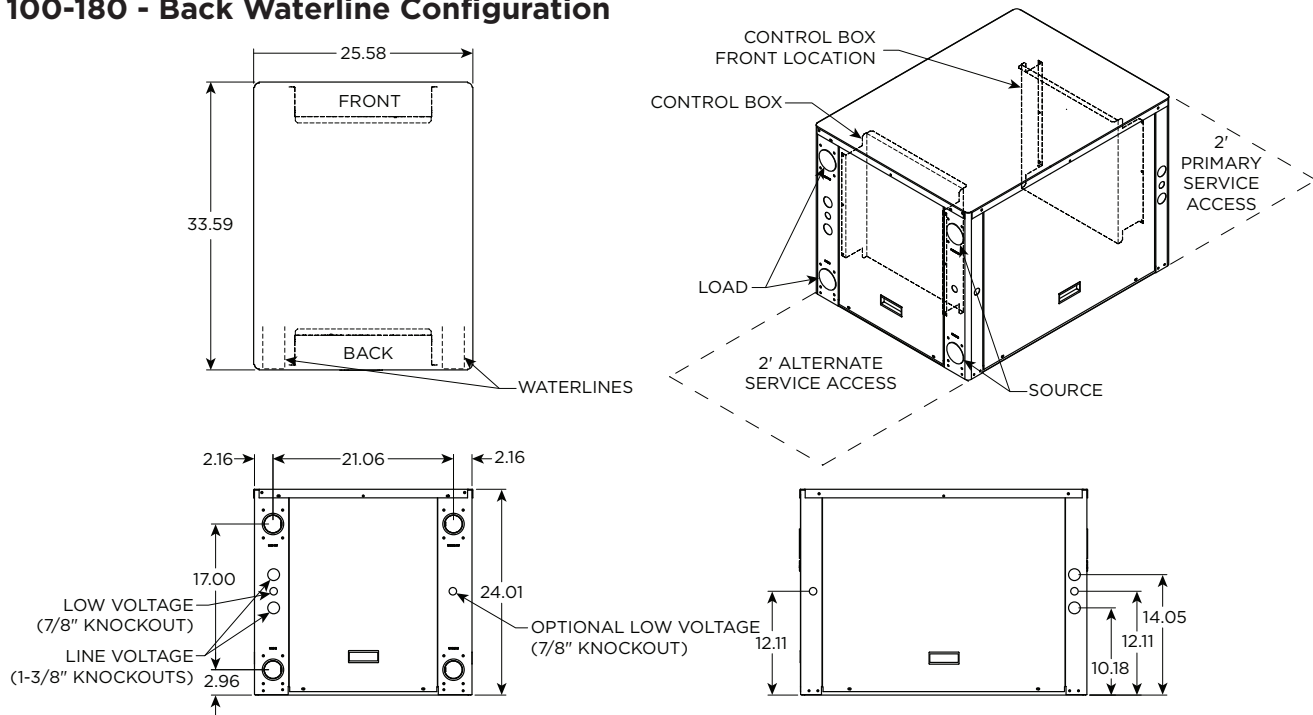

Physical Data

Model	Model			
	100	120	150	180
Compressor (2 each)	Scroll			
Factory Charge R410A, oz [kg]	46 [1.30]	46 [1.30]	46 [1.30]	54 [1.53]
Load Water Connection				
FPT - in	2	2	2	2
Source Water Connection				
FPT - in	2	2	2	2
Weight - Operating, lb [kg]	390 [177]	400 [181]	400 [181]	420 [190]
Weight - Packaged, lb [kg]	385 [175]	395 [179]	395 [179]	415 [188]

12/29/22

Electrical Data

Model	Supply Circuit	Rated Voltage	Voltage Min/Max	Compressor*				Load Pump FLA	Source Pump FLA	Total Unit FLA	Min Circ Amp	Max Fuse/HACR
				MCC	RLA	LRA	LRA**					
100	L1/L2	208-230/60/1	187/253	41.2	26.4	134.0	47.0	-	-	26.4	33.0	50
	L3/L4	208-230/60/1	187/253	41.2	26.4	134.0	47.0	4.2	4.2	34.8	41.4	60
	Single	208-230/60/3	187/253	24.9	16.0	110.0	66.0	-	-	32.0	36.0	50
	Single	460/60/3	414/506	12.1	7.8	52.0	31.0	-	-	15.6	17.6	25
	Single	575/60/3	517/633	8.9	5.7	38.9	-	-	-	11.4	12.8	15
120	L1/L2	208-230/60/1	187/253	47.0	30.1	145.0	51.0	-	-	30.1	37.6	60
	L3/L4	208-230/60/1	187/253	47.0	30.1	145.0	51.0	4.2	4.2	38.5	46.0	70
	Single	208-230/60/3	187/253	28.0	17.3	120.0	72.0	-	-	34.6	38.9	50
	Single	460/60/3	414/506	15.0	9.6	70.0	42.0	-	-	19.2	21.6	30
	Single	575/60/3	517/633	12.5	8.0	53.0	-	-	-	16.0	18.0	25
150	L1/L2	208-230/60/1	187/253	42.0	26.9	145.0	51.0	-	-	26.9	33.6	60
	L3/L4	208-230/60/1	187/253	42.0	26.9	145.0	51.0	4.2	4.2	35.3	42.0	60
	Single	208-230/60/3	187/253	35.0	22.4	190.0	114.0	-	-	44.8	50.4	70
	Single	460/60/3	414/506	19.0	12.2	87.0	52.0	-	-	24.4	27.5	30
	Single	575/60/3	517/633	15.0	9.6	62.0	-	-	-	19.2	21.6	30
180	L1/L2	208-230/60/1	187/253	50.0	32.1	185.0	65.0	-	-	32.1	40.1	70
	L3/L4	208-230/60/1	187/253	50.0	32.1	185.0	65.0	4.2	4.2	40.5	48.5	80
	Single	208-230/60/3	187/253	39.0	26.0	190.0	114.0	-	-	52.0	58.5	80
	Single	460/60/3	414/506	19.0	13.0	100.0	60.0	-	-	26.0	29.3	40
	Single	575/60/3	517/633	14.5	9.3	72.0	-	-	-	18.6	20.9	30

HACR circuit breaker in USA only

* Ratings per each compressor - unit supplied with two

** With optional IntelliStart

3/7/13

Reference Calculations

Heating Calculations: $LWT = EWT - \frac{HE}{GPM \times 500^*}$	Cooling Calculations: $LWT = EWT + \frac{HR}{GPM \times 500^*}$
--	--

NOTE: * When using water. Use 485 for 15% methanol/water or Environol solution.

Legend and Notes

Abbreviations and Definitions

ELT = entering load fluid temperature to heat pump	PSI = pressure drop in pounds per square inch
LLT = leaving load fluid temperature from heat pump	FT HD = pressure drop in feet of head
LGPM = load flow in gallons per minute	KW = kilowatt
LWPD = load heat exchanger water pressure drop	HR = heat rejected in MBTUH
EST = entering source fluid temperature to heat pump	TC = total cooling capacity in MBTUH
LST = leaving source fluid temperature from heat pump	COP = coefficient of performance (HC/KW x 3.413)
SGPM = source flow in gallons per minute	HC = heating capacity in MBTUH
SWPD = source heat exchanger water pressure drop	HE = heat of extraction in MBTUH
EER = cooling energy efficiency (TC/KW)	

Notes to Performance Data Tables

The following notes apply to all performance data tables:

- Three flow rates are shown for each unit. The lowest flow rate shown is used for geothermal open loop/well water systems with a minimum of 50°F EST. The middle flow rate shown is the minimum geothermal closed loop flow rate. The highest flow rate shown is optimum for geothermal closed loop systems and the suggested flow rate for boiler/tower applications.
- Entering water temperatures below 40°F assumes 15% antifreeze solution.
- Interpolation between ELT, EST, and GPM data is permissible.
- Operation in the gray areas is not recommended.

Antifreeze Correction

Catalog performance can be corrected for antifreeze use. Please use the following table and note the example given.

Antifreeze Type	Antifreeze % by wt	Heating		Cooling		Pressure Drop
		Load	Source	Load	Source	
EWT - °F [°C]		80 [26.7]	30 [-1.1]	50 [10.0]	90 [32.2]	30 [-1.1]
Water	0	1.000	1.000	1.000	1.000	1.000
Ethylene Glycol	10	0.990	0.973	0.976	0.991	1.075
	20	0.978	0.943	0.947	0.979	1.163
	30	0.964	0.917	0.921	0.965	1.225
	40	0.953	0.890	0.897	0.955	1.324
	50	0.942	0.865	0.872	0.943	1.419
Propylene Glycol	10	0.981	0.958	0.959	0.981	1.130
	20	0.967	0.913	0.921	0.969	1.270
	30	0.946	0.854	0.869	0.950	1.433
	40	0.932	0.813	0.834	0.937	1.614
	50	0.915	0.770	0.796	0.922	1.816
Ethanol	10	0.986	0.927	0.945	0.991	1.242
	20	0.967	0.887	0.906	0.972	1.343
	30	0.944	0.856	0.869	0.947	1.383
	40	0.926	0.815	0.830	0.930	1.523
	50	0.907	0.779	0.795	0.911	1.639
Methanol	10	0.985	0.957	0.962	0.986	1.127
	20	0.969	0.924	0.929	0.970	1.197
	30	0.950	0.895	0.897	0.951	1.235
	40	0.935	0.863	0.866	0.936	1.323
	50	0.919	0.833	0.836	0.920	1.399



WARNING: Gray area represents antifreeze concentrations greater than 35% by weight and should be avoided due to the extreme performance penalty they represent.

Antifreeze Correction Example

Antifreeze solution is propylene glycol 20% by weight for the source and methanol 10% for the load. Determine the corrected heating at 30°F source and 80°F load as well as pressure drop at 30°F for an Envision Series NDW120. Also, determine the corrected cooling at 90°F source and 50°F load.

The corrected heating capacity at 30°F/80°F would be:

$$98,500 \text{ MBTUH} \times 0.913 \times 0.985 = 88,582 \text{ MBTUH}$$

The corrected cooling capacity at 90°F/50°F would be:

$$113,200 \times 0.969 \times 0.962 = 105,523 \text{ MBTUH}$$

The corrected pressure drop at 30°F and 36 GPM would be:

$$4.9 \text{ psi} \times 1.270 = 6.22 \text{ psi}$$

Load and Source Pressure Drop

Model	GPM	Pressure Drop (psi)				
		30°F	50°F	70°F	90°F	110°F
100	15	1.0	0.8	0.5	0.3	0.1
	23	2.5	2.2	2.0	1.7	1.3
	30	3.8	3.6	3.3	3.1	2.4
	34	4.5	4.3	4.0	3.8	3.0
120	18	1.6	1.3	1.1	0.8	0.6
	28	3.4	3.2	2.9	2.7	2.1
	36	4.9	4.7	4.4	4.2	3.3
	40	5.6	5.4	5.1	4.9	3.9
150	21	2.1	1.9	1.6	1.4	1.0
	32	4.2	3.9	3.7	3.4	2.7
	42	6.0	5.8	5.5	5.3	4.2
	50	7.5	7.3	7.0	6.8	5.5
180	24	2.7	2.4	2.2	1.9	1.5
	36	4.9	4.7	4.4	4.2	3.3
	48	7.1	6.9	6.6	6.4	5.1
	60	9.3	9.1	8.8	8.6	7.0

3/9/09

100 - Performance Data

Cooling Capacity

Source		Load Flow - 15 GPM							Load Flow - 23 GPM							Load Flow - 30 GPM						
EST °F	Flow GPM	ELT °F	LLT °F	TC MBTUH	Power kW	HR MBTUH	EER	LST °F	LLT °F	TC MBTUH	Power kW	HR MBTUH	EER	LST °F	LLT °F	TC MBTUH	Power kW	HR MBTUH	EER	LST °F		
30	15	50	35.6	108.0	3.80	121.0	28.4	46.1	40.3	111.7	3.91	125.1	28.6	46.7	42.3	115.0	4.00	128.6	28.8	47.2		
		70	54.3	117.9	3.90	131.2	30.2	47.5	59.4	121.7	3.99	135.3	30.5	48.0	61.7	125.0	4.07	138.9	30.7	48.5		
		90	73.0	127.9	4.00	141.5	32.0	48.9	78.6	131.7	4.07	145.6	32.3	49.4	81.0	135.0	4.13	149.1	32.7	49.9		
		110	91.6	137.8	4.10	151.8	33.6	50.2	97.7	141.6	4.15	155.8	34.1	50.8	100.3	145.0	4.20	159.3	34.5	51.2		
	23	50	35.3	110.1	3.69	122.7	29.8	40.7	40.1	113.8	3.80	126.7	29.9	41.0	42.2	116.9	3.89	130.2	30.0	41.3		
		70	54.0	120.3	3.76	133.1	32.0	41.6	59.2	124.1	3.86	137.3	32.2	41.9	61.5	127.5	3.94	141.0	32.3	42.3		
		90	72.6	130.4	3.83	143.5	34.1	42.5	78.3	134.5	3.92	147.9	34.4	42.9	80.8	138.1	3.99	151.7	34.6	43.2		
		110	91.3	140.6	3.90	153.9	36.1	43.4	97.4	144.9	3.97	158.5	36.5	43.8	100.1	148.7	4.04	162.5	36.8	44.1		
	30	50	35.1	112.0	3.60	124.3	31.1	38.3	40.0	115.5	3.71	128.2	31.2	38.5	42.1	118.6	3.80	131.6	31.2	38.8		
		70	53.7	122.3	3.64	134.8	33.6	39.0	59.0	126.3	3.74	139.1	33.7	39.3	61.4	129.7	3.83	142.8	33.8	39.5		
		90	72.3	132.7	3.68	145.2	36.1	39.7	78.1	137.0	3.78	149.9	36.3	40.0	80.6	140.9	3.87	154.1	36.4	40.3		
		110	90.9	143.0	3.72	155.7	38.4	40.4	97.1	147.8	3.82	160.8	38.7	40.7	99.9	152.0	3.90	165.3	39.0	41.0		
50	15	50	36.6	100.3	5.23	118.1	19.2	65.7	41.0	103.7	5.33	121.9	19.5	66.2	42.9	106.7	5.41	125.2	19.7	66.7		
		70	55.1	111.5	5.37	129.8	20.8	67.3	60.0	115.0	5.45	133.6	21.1	67.8	62.1	118.1	5.52	137.0	21.4	68.3		
		90	73.6	122.7	5.51	141.4	22.3	68.9	79.0	126.3	5.57	145.3	22.7	69.4	81.4	129.6	5.63	148.8	23.0	69.8		
		110	92.2	133.9	5.65	153.1	23.7	70.4	98.0	137.7	5.69	157.1	24.2	70.9	100.6	141.0	5.73	160.6	24.6	71.4		
	23	50	36.4	102.1	5.09	119.4	20.0	60.4	40.8	105.4	5.18	123.1	20.3	60.7	42.8	108.4	5.26	126.3	20.6	61.0		
		70	54.9	113.5	5.19	131.2	21.9	61.4	59.8	117.2	5.27	135.1	22.2	61.7	62.0	120.4	5.34	138.6	22.6	62.0		
		90	73.3	124.9	5.28	142.9	23.6	62.4	78.8	128.9	5.35	147.1	24.1	62.8	81.2	132.3	5.41	150.8	24.5	63.1		
		110	91.8	136.3	5.38	154.7	25.3	63.5	97.8	140.6	5.44	159.1	25.9	63.8	100.4	144.3	5.49	163.1	26.3	64.2		
	30	50	36.2	103.6	4.98	120.6	20.8	58.0	40.7	106.9	5.06	124.2	21.2	58.3	42.7	109.9	5.13	127.3	21.4	58.5		
		70	54.6	115.3	5.03	132.4	22.9	58.8	59.7	119.0	5.11	136.4	23.3	59.1	61.8	122.3	5.18	140.0	23.6	59.3		
		90	73.1	126.9	5.09	144.2	25.0	59.6	78.6	131.1	5.16	148.7	25.4	59.9	81.0	134.8	5.23	152.6	25.8	60.2		
		110	91.5	138.5	5.14	156.0	26.9	60.4	97.6	143.2	5.21	161.0	27.5	60.7	100.2	147.3	5.28	165.2	27.9	61.0		
70	15	50	37.7	92.5	6.65	115.2	13.9	85.4	41.7	95.6	6.74	118.7	14.2	85.8	43.4	98.4	6.83	121.7	14.4	86.2		
		70	56.0	105.0	6.83	128.3	15.4	87.1	60.6	108.3	6.91	131.9	15.7	87.6	62.6	111.3	6.97	135.1	16.0	88.0		
		90	74.3	117.4	7.02	141.4	16.7	88.8	79.5	121.0	7.07	145.1	17.1	89.4	81.7	124.1	7.12	148.4	17.4	89.8		
		110	Operation not recommended																			
	23	50	37.5	94.0	6.49	116.1	14.5	80.1	41.6	97.1	6.56	119.5	14.8	80.4	43.3	99.8	6.63	122.4	15.1	80.6		
		70	55.8	106.7	6.61	129.2	16.1	81.2	60.4	110.2	6.67	132.9	16.5	81.6	62.5	113.2	6.73	136.2	16.8	81.8		
		90	74.1	119.4	6.74	142.4	17.7	82.4	79.3	123.2	6.79	146.4	18.2	82.7	81.6	126.6	6.83	149.9	18.5	83.0		
		110	Operation not recommended																			
	30	50	37.3	95.3	6.35	116.9	15.0	77.8	41.4	98.4	6.40	120.2	15.4	78.0	43.3	101.1	6.45	123.1	15.7	78.2		
		70	55.6	108.2	6.42	130.1	16.8	78.7	60.3	111.8	6.47	133.8	17.3	78.9	62.3	114.9	6.52	127.1	17.6	79.1		
		90	73.9	121.1	6.49	143.2	18.7	79.5	79.1	125.1	6.54	147.5	19.1	79.8	81.4	128.7	6.58	151.2	19.5	80.1		
		110	Operation not recommended																			
90	15	50	38.7	84.8	8.08	112.3	10.5	105.0	42.4	87.6	8.16	115.5	10.7	105.4	44.0	90.1	8.24	118.2	10.9	105.8		
		70	56.9	98.5	8.30	126.8	11.9	106.9	61.2	101.6	8.37	130.2	12.1	107.4	63.0	104.4	8.42	133.1	12.4	107.8		
		90	75.0	112.2	8.53	141.3	13.2	108.8	79.9	115.7	8.57	144.9	13.5	109.3	82.1	118.7	8.61	148.1	13.8	109.7		
		110	Operation not recommended																			
	23	50	38.5	85.9	7.89	112.8	10.9	99.8	42.3	88.8	7.94	115.9	11.2	100.1	43.9	91.3	7.99	118.6	11.4	100.3		
		70	56.7	99.9	8.04	127.3	12.4	101.1	61.0	103.2	8.08	130.7	12.8	101.4	62.9	106.0	8.12	133.8	13.1	101.6		
		90	74.8	113.9	8.19	141.8	13.9	102.3	79.8	117.6	8.22	145.6	14.3	102.7	81.9	120.8	8.25	149.0	14.6	103.0		
		110	Operation not recommended																			
	30	50	38.4	86.9	7.73	113.2	11.2	97.5	42.2	89.8	7.75	116.2	11.6	97.7	43.8	92.4	7.78	118.9	11.9	97.9		
		70	56.5	101.1	7.81	127.7	12.9	98.5	60.9	104.5	7.84	131.2	13.3	98.7	62.8	107.5	7.86	134.3	13.7	99.0		
		90	74.6	115.3	7.90	142.2	14.6	99.5	79.6	119.2	7.92	146.2	15.1	99.7	81.8	122.6	7.94	149.7	15.4	100.0		
		110	Operation not recommended																			
110	15	50	39.7	77.0	9.50	109.4	8.1	124.6	43.1	79.6	9.58	112.2	8.3	125.0	44.5	81.8	9.65	114.7	8.5	125.3		
		70	57.7	92.0	9.77	125.3	9.4	126.7	61.7	95.0	9.83	128.5	9.7	127.1	63.5	97.5	9.88	131.2	9.9	127.5		
		90	Operation not recommended																			
		110	Operation not recommended																			
	23	50	39.6	77.8	9.29	109.5	8.4	119.5	43.0	80.4	9.32	112.3	8.6	119.8	44.5	82.8	9.36	114.7	8.8	120.0		
		70	57.6	93.1	9.46	125.4	9.8	120.9	61.6	96.2	9.49	128.6	10.1	121.2	63.4	98.9	9.52	131.4	10.4	121.4		
		90	Operation not recommended																			
		110	Operation not recommended																			
	30	50	39.5	78.5	9.10	109.5	8.6	117.3	42.9	81.2	9.10	112.3	8.9	117.5	44.4	83.6	9.10	114.6	9.2	117.6		
		70	57.5	94.0	9.20	125.4	10.2	118.4	61.5	97.2	9.20	128.6	10.6	118.6	63.3	100.1	9.20	131.5	10.9	118.8		
		90	Operation not recommended																			
		110	Operation not recommended																			

NOTE: For part load application, divide capacity by 2.

100 - Performance Data

Heating Capacity

Source		Load Flow - 15 GPM							Load Flow - 23 GPM							Load Flow - 30 GPM						
EWT °F	Flow GPM	ELT °F	LLT °F	HC MBTUH	Power kW	HE MBTUH	COP	LST °F	LLT °F	HC MBTUH	Power kW	HE MBTUH	COP	LST °F	LLT °F	HC MBTUH	Power kW	HE MBTUH	COP	LST °F		
30	23	60	72.2	91.3	5.01	74.2	5.3	20.1	68.2	94.5	4.85	78.0	5.7	23.2	66.5	97.3	4.71	81.2	6.1	24.6		
		80	91.9	89.2	6.64	66.6	3.9	21.1	88.0	92.1	6.46	70.1	4.2	23.9	86.3	94.7	6.31	73.2	4.4	25.1		
		100	111.6	87.2	8.28	58.9	3.1	22.1	107.8	89.8	8.08	62.2	3.3	24.6	106.1	92.1	7.91	65.1	3.4	25.7		
		120	131.3	85.1	9.91	51.3	2.5	23.2	127.6	87.4	9.70	54.3	2.6	25.3	126.0	89.5	9.51	57.0	2.8	26.2		
	30	60	72.3	92.0	5.10	74.6	5.3	20.1	68.4	96.3	4.94	79.4	5.7	23.1	66.7	100.0	4.80	83.6	6.1	24.4		
		80	92.0	89.9	6.77	66.8	3.9	21.1	88.2	93.9	6.59	71.4	4.2	23.8	86.5	97.4	6.43	75.4	4.4	25.0		
100		111.7	87.9	8.43	59.1	3.1	22.1	108.0	91.6	8.24	63.5	3.3	24.5	106.3	94.8	8.07	67.3	3.4	25.5			
120		131.4	85.8	10.10	51.3	2.5	23.2	127.8	89.2	9.89	55.5	2.6	25.2	126.1	92.2	9.70	59.1	2.8	26.1			
50	15	60	73.6	102.2	5.00	85.1	6.0	38.7	69.2	105.4	4.84	88.9	6.4	42.3	67.2	108.3	4.70	92.3	6.8	43.8		
		80	93.3	100.1	6.62	77.5	4.4	39.7	89.0	103.1	6.44	81.1	4.7	42.9	87.0	105.7	6.29	84.2	4.9	44.4		
		100	113.1	98.1	8.20	69.9	3.5	37.4	108.8	100.7	8.00	73.3	3.7	43.6	106.9	103.1	7.88	76.2	3.8	44.9		
		120	132.8	96.0	9.87	62.3	2.9	41.7	128.6	98.4	9.65	65.5	3.0	44.3	126.7	100.5	9.47	68.2	3.1	45.5		
	23	60	74.4	107.7	5.12	90.2	6.2	38.0	69.7	111.9	4.95	95.0	6.6	41.7	67.7	115.5	4.81	99.1	7.0	43.4		
		80	94.1	105.6	6.78	82.5	4.6	39.0	89.5	109.5	6.59	87.0	4.9	42.4	87.5	112.9	6.43	91.0	5.1	43.9		
		100	113.8	103.5	8.44	74.7	3.6	40.0	109.3	107.2	8.23	79.1	3.8	43.1	107.4	110.3	8.06	82.9	4.0	44.5		
		120	133.5	101.5	10.10	67.0	2.9	41.1	129.1	104.8	9.87	71.1	3.1	43.8	127.2	107.7	9.68	74.7	3.3	45.0		
	30	60	75.0	112.4	5.23	94.6	6.3	37.4	70.2	117.5	5.06	100.2	6.8	41.3	68.1	121.9	4.90	105.1	7.3	43.0		
		80	94.7	110.4	6.92	86.8	4.7	38.4	90.0	115.1	6.73	92.2	5.0	42.0	88.0	119.3	6.56	96.9	5.3	43.5		
		100	114.4	108.3	8.61	78.9	3.7	39.5	109.8	112.8	8.40	84.1	3.9	42.7	107.8	116.7	8.21	88.7	4.2	44.1		
		120	134.2	106.3	10.30	71.1	3.0	40.5	129.6	110.4	10.07	76.1	3.2	43.4	127.6	114.1	9.87	80.4	3.4	44.6		
70	15	60	75.2	113.9	5.10	96.5	6.5	57.1	70.3	118.4	4.94	101.6	7.0	61.2	68.2	122.4	4.80	106.0	7.5	62.9		
		80	94.9	111.8	6.74	88.8	4.9	58.2	90.1	116.1	6.57	93.7	5.2	61.9	88.0	119.8	6.41	97.9	5.5	63.5		
		100	114.6	109.8	8.39	81.1	3.8	59.2	109.9	113.7	8.19	85.8	4.1	62.5	107.8	117.2	8.02	89.8	4.3	64.0		
		120	134.4	107.7	10.03	73.5	3.1	60.2	129.7	111.4	9.82	77.9	3.3	63.2	127.6	114.6	9.63	81.7	3.5	64.6		
	23	60	76.5	124.0	5.24	106.1	6.9	55.8	71.2	129.2	5.06	111.9	7.5	60.3	68.9	133.8	4.91	117.0	8.0	62.2		
		80	96.3	122.0	6.92	98.3	5.2	56.9	91.0	126.9	6.73	103.9	5.5	61.0	88.7	131.2	6.55	108.8	5.9	62.7		
		100	116.0	119.9	8.60	90.6	4.1	57.9	110.8	124.5	8.39	95.9	4.4	61.7	108.6	128.6	8.20	100.6	4.6	63.3		
		120	135.7	117.8	10.28	82.8	3.4	59.0	130.6	122.2	10.05	87.9	3.6	62.4	128.4	126.0	9.85	92.4	3.7	63.8		
	30	60	77.7	132.9	5.37	114.6	7.3	54.7	72.1	138.7	5.17	121.0	7.9	59.5	69.6	143.7	5.00	126.7	8.4	61.6		
		80	97.4	130.8	7.08	106.7	5.4	55.8	91.9	136.3	6.86	112.9	5.8	60.2	89.4	141.1	6.68	118.3	6.2	62.1		
		100	117.2	128.8	8.79	98.8	4.3	56.8	111.7	134.0	8.56	104.8	4.6	60.9	109.2	138.5	8.36	110.0	4.9	62.7		
		120	136.9	126.7	10.50	90.9	3.5	57.9	131.4	131.6	10.25	96.7	3.8	61.6	129.1	135.9	10.03	101.7	4.0	63.2		
90	15	60	76.7	125.6	5.20	107.9	7.1	75.6	71.4	131.4	5.04	114.2	7.6	80.1	69.1	136.5	4.90	119.8	8.2	82.0		
		80	96.5	123.5	6.87	100.1	5.3	76.7	91.2	129.1	6.69	106.2	5.7	80.8	88.9	133.9	6.53	111.6	6.0	82.6		
		100	Operation not recommended																			
		120	Operation not recommended																			
	23	60	78.7	140.4	5.36	122.1	7.7	73.7	72.7	146.6	5.17	128.9	8.3	78.8	70.1	152.0	5.01	134.9	8.9	81.0		
		80	98.4	138.3	7.06	114.2	5.7	74.8	92.5	144.2	6.86	120.9	6.2	79.5	90.0	149.4	6.68	126.6	6.6	81.6		
		100	Operation not recommended																			
		120	Operation not recommended																			
	30	60	80.4	153.3	5.50	134.6	8.2	72.1	73.9	159.9	5.29	141.8	8.9	77.7	71.0	165.6	5.10	148.2	9.5	80.1		
		80	100.2	151.3	7.23	126.6	6.1	73.1	93.7	157.5	7.00	133.6	6.6	78.4	90.9	163.0	6.80	139.8	7.0	80.7		
		100	Operation not recommended																			
		120	Operation not recommended																			

NOTE: For part load application, divide capacity by 2.

120 - Performance Data

Cooling Capacity

Source		Load Flow - 18 GPM							Load Flow - 28 GPM					Load Flow - 36 GPM								
EST °F	Flow GPM	ELT °F	LLT °F	TC MBTUH	Power kW	HR MBTUH	EER	LST °F	LLT °F	TC MBTUH	Power kW	HR MBTUH	EER	LST °F	LLT °F	TC MBTUH	Power kW	HR MBTUH	EER	LST °F		
30	18	50	35.8	128.0	5.26	145.9	24.3	49.5	40.5	132.6	5.30	150.7	25.0	50.1	42.4	136.3	5.34	154.5	25.5	50.6		
		70	54.0	143.7	5.43	162.2	26.5	51.6	59.4	148.9	5.47	167.5	27.2	52.3	61.5	153.0	5.51	171.8	27.8	52.9		
		90	72.3	159.3	5.60	178.4	28.5	53.8	78.2	165.1	5.64	184.4	29.2	54.6	80.6	169.7	5.68	189.1	29.9	55.2		
		110	90.6	175.0	5.77	194.7	30.3	56.0	97.0	181.3	5.81	201.2	31.2	56.8	99.6	186.4	5.85	206.4	31.9	57.5		
	28	50	35.4	131.3	5.05	148.6	26.0	42.9	40.3	136.1	5.10	153.5	26.7	43.3	42.2	139.9	5.13	157.4	27.3	43.7		
		70	53.6	147.6	5.18	165.2	28.5	44.4	59.1	152.9	5.22	170.7	29.3	44.8	61.3	157.1	5.26	175.1	29.9	45.2		
		90	71.8	163.8	5.31	181.9	30.9	45.8	77.9	169.7	5.35	188.0	31.7	46.3	80.3	174.4	5.38	192.8	32.4	46.8		
		110	90.0	180.0	5.43	198.5	33.1	47.3	96.7	186.5	5.48	205.2	34.1	47.8	99.3	191.7	5.51	210.5	34.8	48.3		
	36	50	35.1	134.0	4.89	150.7	27.4	40.0	40.1	138.8	4.93	155.7	28.2	40.4	42.1	142.7	4.96	159.6	28.8	40.6		
		70	53.3	150.7	4.98	167.7	30.3	41.2	58.8	156.1	5.02	173.2	31.1	41.5	61.1	160.5	5.05	177.7	31.8	41.8		
		90	71.4	167.3	5.07	184.6	33.0	42.3	77.6	173.4	5.11	190.8	33.9	42.7	80.1	178.2	5.15	195.8	34.6	43.1		
		110	89.6	184.0	5.16	201.6	35.7	43.4	96.4	190.7	5.20	208.4	36.6	43.9	99.1	196.0	5.24	213.9	37.4	44.3		
50	18	50	36.7	119.8	6.79	142.9	17.6	69.1	41.1	124.1	6.84	147.4	18.1	69.7	42.9	127.5	6.89	151.0	18.5	70.1		
		70	55.0	135.4	6.95	159.1	19.5	71.2	60.0	140.3	7.01	164.2	20.0	71.9	62.0	144.2	7.06	168.3	20.4	72.4		
		90	73.2	151.1	7.12	175.4	21.2	73.4	78.8	156.5	7.18	181.0	21.8	74.1	81.1	160.9	7.23	185.6	22.3	74.7		
		110	91.5	166.8	7.29	191.6	22.9	75.6	97.7	172.8	7.35	197.9	23.5	76.4	100.1	177.6	7.40	202.8	24.0	77.0		
	28	50	36.2	123.8	6.51	146.0	19.0	62.7	40.8	128.3	6.56	150.7	19.5	63.1	42.7	131.8	6.61	154.4	20.0	63.4		
		70	54.4	140.1	6.64	162.8	21.1	64.2	59.6	145.2	6.70	168.0	21.7	64.6	61.7	149.2	6.74	172.2	22.1	65.0		
		90	72.6	156.4	6.78	179.6	23.1	65.6	78.4	162.1	6.83	185.4	23.7	66.1	80.7	166.6	6.88	190.1	24.2	66.5		
		110	90.8	172.8	6.91	196.3	25.0	67.1	97.2	179.0	6.97	202.8	25.7	67.6	99.8	184.0	7.01	207.9	26.2	68.1		
	36	50	35.9	127.1	6.29	148.5	20.2	59.9	40.6	131.6	6.34	153.3	20.8	60.2	42.5	135.3	6.38	157.1	21.2	60.5		
		70	54.0	143.9	6.40	165.7	22.5	61.0	59.4	149.1	6.45	171.1	23.1	61.4	61.4	153.2	6.49	175.4	23.6	61.7		
		90	72.1	160.7	6.50	182.9	24.7	62.2	78.1	166.5	6.55	188.9	25.4	62.6	80.5	171.2	6.60	193.7	26.0	62.9		
		110	90.3	177.6	6.60	200.1	26.9	63.3	96.9	184.0	6.66	206.7	27.6	63.8	99.5	189.1	6.70	212.0	28.2	64.1		
70	18	50	37.6	111.5	8.31	139.9	13.4	88.6	41.7	115.5	8.38	144.1	13.8	89.2	43.4	118.8	8.44	147.5	14.1	89.7		
		70	55.9	127.2	8.48	156.1	15.0	90.8	60.6	131.8	8.55	160.9	15.4	91.5	62.5	135.4	8.61	164.8	15.7	92.0		
		90	74.1	142.8	8.65	172.3	16.5	93.0	79.4	148.0	8.72	177.7	17.0	93.7	81.5	152.1	8.78	182.1	17.3	94.3		
		110	Operation not recommended																			
	28	50	37.1	116.3	7.97	143.5	14.6	82.5	41.4	120.5	8.03	147.9	15.0	82.9	43.1	123.8	8.09	151.4	15.3	83.2		
		70	55.3	132.7	8.11	160.4	16.4	83.9	60.2	137.5	8.17	165.4	16.8	84.4	62.1	141.3	8.23	169.4	17.2	84.7		
		90	73.4	149.1	8.25	177.2	18.1	85.4	79.0	154.5	8.32	182.9	18.6	85.9	81.2	158.8	8.37	187.3	19.0	86.3		
		110	Operation not recommended																			
	36	50	36.7	120.1	7.70	146.4	15.6	79.8	41.1	124.4	7.76	150.9	16.0	80.1	42.9	127.9	7.81	154.5	16.4	80.3		
		70	54.8	137.1	7.81	163.8	17.6	80.9	59.9	142.1	7.87	168.9	18.0	81.3	61.9	146.0	7.93	173.1	18.4	81.5		
		90	72.9	154.1	7.93	181.2	19.4	82.1	78.6	159.7	7.99	187.0	20.0	82.5	80.9	164.1	8.05	191.6	20.4	82.8		
		110	Operation not recommended																			
90	18	50	38.5	103.3	9.84	136.8	10.5	108.2	42.4	107.0	9.92	140.8	10.8	108.8	43.9	110.0	9.98	144.0	11.0	109.2		
		70	56.8	118.9	10.00	153.0	11.9	110.4	61.2	123.2	10.09	157.6	12.2	111.0	63.0	126.7	10.15	161.3	12.5	111.5		
		90	75.0	134.6	10.17	169.3	13.2	112.6	80.0	139.4	10.25	174.4	13.6	113.3	82.0	143.3	10.32	178.5	13.9	113.8		
		110	Operation not recommended																			
	28	50	37.9	108.8	9.43	140.9	11.5	102.3	42.0	112.7	9.50	145.1	11.9	102.6	43.6	115.8	9.56	148.5	12.1	102.9		
		70	56.1	125.3	9.57	157.9	13.1	103.7	60.7	129.8	9.65	162.7	13.4	104.1	62.6	133.4	9.71	166.5	13.7	104.5		
		90	74.2	141.8	9.72	174.9	14.6	105.2	79.5	146.9	9.80	180.3	15.0	105.7	81.6	151.0	9.86	184.6	15.3	106.1		
		110	Operation not recommended																			
	36	50	37.4	113.2	9.10	144.2	12.4	99.6	41.6	117.2	9.17	148.5	12.8	99.9	43.3	120.5	9.23	152.0	13.1	100.1		
		70	55.5	130.3	9.23	161.8	14.1	100.8	60.4	135.0	9.30	166.8	14.5	101.1	62.3	138.8	9.36	170.7	14.8	101.4		
		90	73.6	147.5	9.36	179.4	15.8	102.0	79.1	152.8	9.43	185.0	16.2	102.3	81.3	157.1	9.49	189.5	16.5	102.6		
		110	Operation not recommended																			
NOTE: For part load application, divide capacity by 2.	18	50	39.4	95.0	11.36	133.8	8.4	127.8	43.0	98.4	11.45	137.5	8.6	128.3	44.4	101.2	11.53	140.5	8.8	128.7		
		70	57.7	110.7	11.53	150.0	9.6	130.0	61.8	114.7	11.62	154.3	9.9	130.6	63.5	117.9	11.70	157.8	10.1	131.0		
		90	Operation not recommended																			
		110	Operation not recommended																			
	28	50	38.8	101.2	10.88	138.4	9.3	122.0	42.5	104.9	10.97	142.3	9.6	122.4	44.0	107.8	11.04	145.5	9.8	122.7		
		70	56.9	117.3	11.04	155.5	10.7	123.5	61.3	122.1	11.13	160.0	11.0	123.9	63.0	125.5	11.20	163.7	11.2	124.2		
		90	Operation not recommended																			
		110	Operation not recommended																			
	36	50	38.2	106.2	10.50	142.0	10.1	119.5	42.1	110.0	10.58	146.1	10.4	119.7	43.7	113.1	10.65	149.4	10.6	120.0		
		70	56.3	123.5	10.64	159.9	11.6	120.7	60.9	128.0	10.73	164.6	11.9	121.0	62.7	131.6	10.80	168.4	12.2	121.2		
		90	Operation not recommended																			
		110	Operation not recommended																			

NOTE: For part load application, divide capacity by 2.

120 - Performance Data

Heating Capacity

Source		Load Flow - 18 GPM							Load Flow - 28 GPM							Load Flow - 36 GPM						
EWT °F	Flow GPM	ELT °F	LLT °F	HC MBTUH	Power kW	HE MBTUH	COP	LST °F	LLT °F	HC MBTUH	Power kW	HE MBTUH	COP	LST °F	LLT °F	HC MBTUH	Power kW	HE MBTUH	COP	LST °F		
30	28	60	71.0	98.9	5.36	80.6	5.4	21.0	67.3	102.4	5.44	83.8	5.5	24.0	65.8	105.2	5.51	86.4	5.6	25.2		
		80	90.7	96.2	7.16	71.8	3.9	22.0	87.1	99.6	7.26	74.9	4.0	24.7	85.7	102.4	7.34	77.3	4.1	25.7		
		100	110.4	93.6	8.96	63.0	3.1	23.0	106.9	96.9	9.08	65.9	3.1	25.3	105.5	99.6	9.18	68.3	3.2	26.2		
		120	130.1	90.9	10.76	54.2	2.5	24.0	126.7	94.2	10.90	57.0	2.5	25.9	125.4	96.9	11.01	59.3	2.6	26.7		
	36	60	71.2	101.2	5.40	82.8	5.5	20.8	67.6	106.1	5.51	87.3	5.6	23.8	66.1	110.0	5.60	90.9	5.8	25.0		
		80	90.9	98.5	7.20	74.0	4.0	21.8	87.4	103.4	7.33	78.4	4.1	24.4	86.0	107.2	7.43	81.9	4.2	25.5		
		100	110.7	95.9	9.00	65.2	3.1	22.8	107.2	100.6	9.15	69.4	3.2	25.0	105.8	104.5	9.27	72.8	3.3	26.0		
		120	130.4	93.2	10.80	56.4	2.5	23.7	127.0	97.9	10.97	60.5	2.6	25.7	125.7	101.7	11.10	63.8	2.7	26.5		
50	18	60	72.6	113.4	5.53	94.5	6.0	39.5	68.4	116.9	5.59	97.8	6.1	43.0	66.7	119.7	5.63	100.5	6.2	44.4		
		80	92.3	110.7	7.33	85.7	4.4	40.5	88.2	114.2	7.41	88.9	4.5	43.6	86.5	117.0	7.47	91.5	4.6	44.9		
		100	112.0	108.0	9.13	76.9	3.5	41.5	108.0	111.5	9.23	80.0	3.5	44.3	106.3	114.2	9.30	82.5	3.6	45.4		
		120	131.7	105.4	10.93	68.1	2.8	42.4	127.8	108.7	11.04	71.1	2.9	44.9	126.2	111.4	11.13	73.4	2.9	45.9		
	28	60	73.3	119.7	5.63	100.5	6.2	38.8	68.9	124.5	5.70	105.1	6.4	42.5	67.1	128.4	5.76	108.7	6.5	44.0		
		80	93.0	117.1	7.43	91.7	4.6	39.8	88.7	121.8	7.52	96.1	4.7	43.1	87.0	125.6	7.60	99.7	4.8	44.5		
		100	112.7	114.4	9.23	82.9	3.6	40.8	108.5	119.1	9.34	87.2	3.7	43.8	106.8	122.8	9.43	90.7	3.8	45.0		
		120	132.4	111.7	11.03	74.1	3.0	41.8	128.3	116.4	11.16	78.3	3.1	44.4	126.7	120.1	11.26	81.6	3.1	45.5		
	36	60	73.9	124.8	5.70	105.4	6.4	38.3	69.3	130.6	5.79	110.9	6.6	42.1	67.5	135.3	5.87	115.2	6.8	43.6		
		80	93.6	122.1	7.50	96.5	4.8	39.3	89.1	127.9	7.61	101.9	4.9	42.7	87.4	132.5	7.70	106.2	5.0	44.1		
		100	113.3	119.5	9.30	87.7	3.8	40.3	108.9	125.2	9.43	93.0	3.9	43.4	107.2	129.7	9.53	97.2	4.0	44.6		
		120	133.0	116.8	11.10	78.9	3.1	41.2	128.7	122.4	11.25	84.1	3.2	44.0	127.1	127.0	11.37	88.2	3.3	45.1		
70	18	60	74.5	130.7	5.77	111.1	6.6	57.7	69.7	136.1	5.82	116.2	6.9	61.7	67.8	140.4	5.87	120.3	7.0	63.3		
		80	94.2	128.1	7.57	102.2	5.0	58.6	89.5	133.4	7.64	107.3	5.1	62.3	87.6	137.6	7.70	111.3	5.2	63.8		
		100	113.9	125.4	9.37	93.4	3.9	59.6	109.3	130.6	9.46	98.4	4.0	63.0	107.5	134.8	9.53	102.3	4.1	64.3		
		120	133.6	122.7	11.17	84.6	3.2	60.6	129.1	127.9	11.28	89.4	3.3	63.6	127.3	132.1	11.37	93.3	3.4	64.8		
	28	60	75.6	140.5	5.90	120.4	7.0	56.6	70.5	146.7	5.96	126.3	7.2	61.0	68.4	151.6	6.01	131.0	7.4	62.7		
		80	95.3	137.9	7.70	111.6	5.3	57.6	90.3	143.9	7.78	117.4	5.4	61.6	88.3	148.8	7.85	122.0	5.6	63.2		
		100	115.0	135.2	9.50	102.8	4.2	58.6	110.1	141.2	9.60	108.5	4.3	62.3	108.1	146.0	9.68	113.0	4.4	63.7		
		120	134.7	132.5	11.30	94.0	3.4	59.6	129.9	138.5	11.42	99.5	3.6	62.9	128.0	143.3	11.51	104.0	3.6	64.2		
	36	60	76.5	148.4	6.00	127.9	7.2	55.8	71.1	155.1	6.07	134.4	7.5	60.4	68.9	160.5	6.13	139.6	7.7	62.2		
		80	96.2	145.7	7.80	119.1	5.5	56.8	90.9	152.4	7.89	125.5	5.7	61.0	88.8	157.8	7.97	130.6	5.8	62.7		
		100	115.9	143.1	9.60	110.3	4.4	57.7	110.7	149.7	9.71	116.6	4.5	61.7	108.6	155.0	9.80	121.6	4.6	63.2		
		120	135.6	140.4	11.40	101.5	3.6	58.7	130.5	147.0	11.53	107.6	3.7	62.3	128.5	152.2	11.63	112.5	3.8	63.7		
90	18	60	76.5	148.1	6.00	127.6	7.2	75.8	71.1	155.3	6.06	134.6	7.5	80.4	68.9	161.0	6.10	140.2	7.7	82.2		
		80	96.2	145.4	7.80	118.8	5.5	76.8	90.9	152.5	7.87	125.7	5.7	81.0	88.8	158.2	7.93	131.2	5.8	82.7		
		100	Operation not recommended																			
		120	Operation not recommended																			
	28	60	77.9	161.4	6.17	140.3	7.7	74.4	72.1	168.8	6.22	147.6	8.0	79.5	69.7	174.8	6.27	153.4	8.2	81.5		
		80	97.6	158.7	7.97	131.5	5.8	75.4	91.9	166.1	8.04	138.7	6.1	80.1	89.6	172.0	8.10	144.4	6.2	82.0		
		100	Operation not recommended																			
		120	Operation not recommended																			
36	60	79.1	172.0	6.30	150.5	8.0	73.3	72.8	179.7	6.36	158.0	8.3	78.7	70.3	185.8	6.40	164.0	8.5	80.9			
	80	98.8	169.3	8.10	141.7	6.1	74.3	92.6	176.9	8.17	149.1	6.3	79.4	90.2	183.0	8.23	154.9	6.5	81.4			
	100	Operation not recommended																				
	120	Operation not recommended																				

NOTE: For part load application, divide capacity by 2.

150 - Performance Data

Cooling Capacity

Source		Load Flow - 21 GPM							Load Flow - 32 GPM							Load Flow - 42 GPM						
EST °F	Flow GPM	ELT °F	LLT °F	TC MBTUH	Power kW	HR MBTUH	EER	LST °F	LLT °F	TC MBTUH	Power kW	HR MBTUH	EER	LST °F	LLT °F	TC MBTUH	Power kW	HR MBTUH	EER	LST °F		
30	21	50	35.3	153.9	5.76	173.5	26.7	46.5	40.0	159.9	5.9	179.9	27.3	47.1	42.1	165.4	5.94	185.7	27.9	47.7		
		70	52.3	185.8	6.22	207.0	29.8	49.7	57.9	193.1	6.3	214.7	30.5	50.4	60.5	199.8	6.42	221.7	31.1	51.1		
		90	69.3	217.7	6.69	240.5	32.6	52.9	75.9	226.3	6.8	249.5	33.3	53.8	78.9	234.1	6.89	257.6	34.0	54.5		
		110	86.2	249.6	7.15	274.0	34.9	56.1	93.8	259.5	7.3	284.2	35.7	57.1	97.2	268.4	7.37	293.5	36.4	58.0		
	32	50	34.3	164.4	5.5	183.1	30.0	41.4	39.3	171.1	5.6	190.1	30.7	41.9	41.6	177.3	5.7	196.6	31.3	42.3		
		70	51.1	198.7	5.93	218.9	33.5	43.7	57.1	206.7	6.0	227.3	34.3	44.2	59.8	214.0	6.11	234.9	35.0	44.7		
		90	67.8	233.1	6.37	254.8	36.6	45.9	74.9	242.4	6.5	264.4	37.5	46.5	78.1	250.8	6.57	273.2	38.2	47.1		
		110	84.5	267.4	6.8	290.7	39.3	48.2	92.6	278.0	6.9	301.6	40.2	48.8	96.3	287.6	7.0	311.5	41.0	49.5		
	42	50	33.4	173.9	5.24	191.8	33.2	39.1	38.7	181.3	5.3	199.4	34.1	39.5	41.0	188.0	5.40	206.4	34.8	39.8		
		70	50.0	210.5	5.66	229.8	37.2	40.9	56.3	219.1	5.8	238.8	38.1	41.4	59.2	227.0	5.83	246.9	38.9	41.8		
		90	66.5	247.1	6.08	267.8	40.6	42.8	73.9	257.0	6.2	278.1	41.6	43.2	77.3	266.0	6.27	287.4	42.4	43.7		
		110	83.0	283.7	6.50	305.8	43.6	44.6	91.6	294.8	6.6	317.4	44.6	45.1	95.5	305.0	6.70	327.9	45.5	45.6		
50	21	50	36.4	143.2	7.49	168.8	19.1	66.1	40.7	148.9	7.6	174.9	19.6	66.7	42.7	154.0	7.73	180.4	19.9	67.2		
		70	53.3	175.2	8.02	202.5	21.9	69.3	58.6	182.1	8.1	209.9	22.4	70.0	61.0	188.4	8.26	216.6	22.8	70.6		
		90	70.3	207.2	8.54	236.3	24.3	72.5	76.5	215.3	8.7	244.9	24.8	73.3	79.4	222.7	8.80	252.8	25.3	74.1		
		110	87.2	239.1	9.06	270.0	26.4	75.7	94.5	248.5	9.2	280.0	27.0	76.7	97.8	257.1	9.34	289.0	27.5	77.5		
	32	50	35.5	151.8	7.2	176.2	21.2	61.0	40.1	158.0	7.3	182.8	21.7	61.4	42.2	163.7	7.4	188.8	22.2	61.8		
		70	52.3	185.8	7.65	211.9	24.3	63.2	57.9	193.3	7.8	219.8	24.9	63.7	60.5	200.1	7.89	227.0	25.4	64.2		
		90	69.1	219.9	8.15	247.7	27.0	65.5	75.7	228.6	8.3	256.9	27.6	66.1	78.7	236.6	8.40	265.2	28.2	66.6		
		110	85.8	253.9	8.6	283.4	29.4	67.7	93.5	263.9	8.8	293.9	30.0	68.4	97.0	273.0	8.9	303.4	30.6	69.0		
	42	50	34.8	159.6	6.84	182.9	23.3	58.7	39.6	166.3	6.9	190.1	23.9	59.1	41.8	172.5	7.05	196.6	24.5	59.4		
		70	51.4	195.5	7.32	220.5	26.7	60.5	57.3	203.5	7.4	228.9	27.4	60.9	60.0	210.8	7.54	236.6	28.0	61.3		
		90	68.0	231.4	7.79	258.0	29.7	62.3	75.0	240.7	7.9	267.7	30.4	62.7	78.1	249.2	8.03	276.6	31.0	63.2		
		110	84.5	267.4	8.27	295.6	32.3	64.1	92.6	277.9	8.4	306.6	33.1	64.6	96.3	287.5	8.53	316.6	33.7	65.1		
70	21	50	37.4	132.6	9.22	164.1	14.4	85.6	41.4	137.8	9.4	169.8	14.7	86.2	43.2	142.6	9.51	175.0	15.0	86.7		
		70	54.3	164.6	9.81	198.1	16.8	88.9	59.3	171.1	10.0	205.1	17.2	89.5	61.6	177.0	10.11	211.5	17.5	90.1		
		90	71.3	196.6	10.39	232.1	18.9	92.1	77.2	204.4	10.6	240.4	19.4	92.9	79.9	211.4	10.71	248.0	19.7	93.6		
		110	Operation not recommended																			
	32	50	36.7	139.2	8.8	169.3	15.8	80.6	40.9	144.9	9.0	175.5	16.2	81.0	42.9	150.1	9.1	181.1	16.5	81.3		
		70	53.5	172.9	9.37	204.9	18.5	82.8	58.8	179.9	9.52	212.4	18.9	83.3	61.1	186.2	9.66	219.2	19.3	83.7		
		90	70.3	206.7	9.93	240.5	20.8	85.0	76.6	214.9	10.09	249.3	21.3	85.6	79.4	222.4	10.23	257.3	21.7	86.1		
		110	Operation not recommended																			
	42	50	36.2	145.2	8.44	174.0	17.2	78.3	40.5	151.4	8.6	180.7	17.7	78.6	42.5	157.0	8.70	186.7	18.0	78.9		
		70	52.8	180.5	8.97	211.1	20.1	80.1	58.3	187.9	9.1	219.0	20.6	80.4	60.7	194.7	9.25	226.2	21.0	80.8		
		90	69.4	215.8	9.51	248.2	22.7	81.8	76.0	224.5	9.7	257.4	23.2	82.3	78.9	232.3	9.80	265.8	23.7	82.7		
		110	Operation not recommended																			
90	21	50	38.4	122.0	10.96	159.3	11.1	105.2	42.1	126.8	11.1	164.8	11.4	105.7	43.8	131.1	11.30	169.7	11.6	106.2		
		70	55.3	154.0	11.60	193.6	13.3	108.4	60.0	160.1	11.79	200.3	13.6	109.1	62.1	165.6	11.96	206.4	13.8	109.7		
		90	72.3	186.1	12.24	227.8	15.2	111.7	77.9	193.4	12.44	235.9	15.5	112.5	80.5	200.1	12.62	243.1	15.8	113.2		
		110	Operation not recommended																			
	32	50	37.9	126.6	10.5	162.4	12.1	100.1	41.8	131.8	10.6	168.2	12.4	100.5	43.5	136.6	10.8	173.4	12.6	100.8		
		70	54.8	160.0	11.09	197.9	14.4	102.4	59.6	166.5	11.27	205.0	14.8	102.8	61.8	172.4	11.43	211.4	15.1	103.2		
		90	71.6	193.5	11.71	233.4	16.5	104.6	77.4	201.2	11.90	241.7	16.9	105.1	80.1	208.2	12.07	249.3	17.2	105.6		
		110	Operation not recommended																			
	42	50	37.5	130.9	10.04	165.1	13.0	97.9	41.5	136.4	10.2	171.3	13.4	98.2	43.3	141.5	10.35	176.8	13.7	98.4		
		70	54.2	165.5	10.63	201.8	15.6	99.6	59.2	172.3	10.80	209.2	16.0	100.0	61.5	178.5	10.96	215.9	16.3	100.3		
		90	70.9	200.2	11.22	238.5	17.8	101.4	77.0	208.2	11.40	247.1	18.3	101.8	79.7	215.5	11.57	255.0	18.6	102.1		
		110	Operation not recommended																			
110	21	50	39.4	111.3	12.69	154.6	8.8	124.7	42.8	115.7	12.9	159.7	9.0	125.2	44.3	119.7	13.08	164.3	9.2	125.7		
		70	56.3	143.4	13.39	189.1	10.7	128.0	60.7	149.1	13.61	195.5	11.0	128.6	62.7	154.2	13.81	201.3	11.2	129.2		
		90	Operation not recommended																			
		110	Operation not recommended																			
	32	50	39.1	114.1	12.1	155.5	9.4	119.7	42.6	118.7	12.3	160.8	9.6	120.1	44.1	123.0	12.5	165.7	9.8	120.4		
		70	56.0	147.2	12.81	190.9	11.5	121.9	60.4	153.1	13.02	197.5	11.8	122.3	62.5	158.5	13.21	203.5	12.0	122.7		
		90	Operation not recommended																			
		110	Operation not recommended																			
	42	50	38.9	116.6	11.64	156.3	10.0	117.4	42.4	121.5	11.8	161.9	10.3	117.7	44.0	126.0	12.00	166.9	10.5	117.9		
		70	55.7	150.6	12.29	192.5	12.3	119.2	60.2	156.7	12.49	199.3	12.6	119.5	62.3	162.3	12.67	205.6	12.8	119.8		
		90	Operation not recommended																			
		110	Operation not recommended																			

NOTE: For part load application, divide capacity by 2.

150 - Performance Data

Heating Capacity

Source		Load Flow - 21 GPM							Load Flow - 32 GPM							Load Flow - 42 GPM						
EWT °F	Flow GPM	ELT °F	LLT °F	HC MBTUH	Power kW	HE MBTUH	COP	LST °F	LLT °F	HC MBTUH	Power kW	HE MBTUH	COP	LST °F	LLT °F	HC MBTUH	Power kW	HE MBTUH	COP	LST °F		
30	32	60	72.6	132.7	7.7	106.4	5.0	19.9	68.4	133.8	7.6	107.9	5.2	23.3	66.4	134.7	7.4	109.3	5.3	24.8		
		80	92.0	126.1	11.0	88.6	3.4	21.6	88.0	127.6	10.8	90.8	3.5	24.3	86.1	128.9	10.6	92.7	3.6	25.6		
		100	111.4	119.6	14.3	70.9	2.5	23.2	107.6	121.4	14.0	73.6	2.5	25.4	105.9	123.0	13.7	76.1	2.6	26.4		
		120	130.8	113.0	17.6	53.1	1.9	24.9	127.2	115.2	17.2	56.5	2.0	26.5	125.6	117.1	16.9	59.6	2.0	27.2		
	42	60	72.9	135.9	7.8	109.4	5.1	19.6	68.6	137.0	7.6	111.0	5.3	23.1	66.6	138.0	7.5	112.4	5.4	24.6		
		80	92.3	129.2	11.1	91.5	3.4	21.3	88.2	130.7	10.9	93.6	3.5	24.1	86.3	132.0	10.7	95.6	3.6	25.4		
		100	111.7	122.5	14.4	73.5	2.5	23.0	107.8	124.3	14.1	76.3	2.6	25.2	106.0	126.0	13.8	78.8	2.7	26.2		
		120	131.0	115.8	17.7	55.5	1.9	24.7	127.4	118.0	17.3	58.9	2.0	26.3	125.7	120.0	17.0	62.0	2.1	27.0		
50	21	60	75.6	163.4	8.3	135.3	5.8	37.1	70.3	164.7	8.1	137.1	6.0	41.4	67.9	165.9	8.0	138.7	6.1	43.4		
		80	94.9	156.0	11.2	117.8	4.1	38.8	89.9	157.8	11.0	120.3	4.2	42.5	87.6	159.4	10.8	122.6	4.3	44.2		
		100	114.2	148.6	14.1	100.4	3.1	40.4	109.4	150.8	13.9	103.5	3.2	43.5	107.3	152.8	13.6	106.4	3.3	44.9		
		120	133.4	141.2	17.1	82.9	2.4	42.1	129.0	143.9	16.7	86.8	2.5	44.6	127.0	146.3	16.4	90.3	2.6	45.7		
	32	60	76.0	168.0	8.3	139.6	5.9	36.7	70.6	169.3	8.2	141.4	6.1	41.2	68.1	170.5	8.0	143.1	6.2	43.2		
		80	95.3	160.3	11.3	121.8	4.2	38.4	90.1	162.1	11.1	124.4	4.3	42.2	87.8	163.8	10.9	126.7	4.4	44.0		
		100	114.5	152.7	14.2	104.1	3.1	40.1	109.7	155.0	14.0	107.3	3.3	43.3	107.5	157.1	13.7	110.3	3.4	44.7		
		120	133.8	145.1	17.2	86.4	2.5	41.8	129.2	147.8	16.9	90.3	2.6	44.4	127.2	150.3	16.5	93.9	2.7	45.5		
	42	60	76.4	172.0	8.4	143.4	6.0	36.3	70.8	173.4	8.2	145.3	6.2	40.9	68.3	174.7	8.1	147.0	6.3	43.0		
		80	95.6	164.2	11.4	125.5	4.2	38.1	90.4	166.1	11.2	128.0	4.4	42.0	88.0	167.8	11.0	130.4	4.5	43.8		
		100	114.9	156.4	14.4	107.5	3.2	39.8	109.9	158.8	14.1	110.8	3.3	43.1	107.7	160.9	13.8	113.8	3.4	44.6		
		120	134.2	148.6	17.3	89.5	2.5	41.5	129.5	151.4	17.0	93.5	2.6	44.2	127.3	154.0	16.7	97.1	2.7	45.4		
70	21	60	78.8	197.8	8.9	167.5	6.5	54.0	72.5	199.3	8.7	169.6	6.7	59.4	69.6	200.8	8.6	171.5	6.9	61.8		
		80	98.0	189.3	11.5	150.1	4.8	55.7	92.0	191.4	11.3	153.0	5.0	60.4	89.2	193.4	11.1	155.6	5.1	62.6		
		100	117.2	180.8	14.1	132.7	3.8	57.4	111.5	183.5	13.8	136.3	3.9	61.5	108.9	186.0	13.6	139.6	4.0	63.4		
		120	136.4	172.3	16.7	115.3	3.0	59.0	131.0	175.6	16.4	119.7	3.1	62.5	128.5	178.6	16.1	123.7	3.3	64.1		
	32	60	79.4	203.2	8.9	172.7	6.7	53.6	72.8	204.8	8.8	174.9	6.8	59.1	69.8	206.3	8.6	176.8	7.0	61.6		
		80	98.5	194.5	11.6	155.0	4.9	55.2	92.3	196.7	11.4	157.9	5.1	60.1	89.5	198.7	11.2	160.6	5.2	62.4		
		100	117.7	185.8	14.2	137.3	3.8	56.9	111.8	188.6	13.9	141.0	4.0	61.2	109.1	191.1	13.7	144.4	4.1	63.1		
		120	136.9	177.1	16.9	119.6	3.1	58.6	131.3	180.5	16.5	124.1	3.2	62.2	128.7	183.5	16.2	128.2	3.3	63.9		
	42	60	79.8	208.2	9.0	177.4	6.8	53.1	73.1	209.8	8.8	179.6	7.0	58.8	70.1	211.3	8.7	181.6	7.1	61.4		
		80	99.0	199.2	11.7	159.4	5.0	54.8	92.6	201.5	11.4	162.5	5.2	59.8	89.7	203.6	11.2	165.2	5.3	62.1		
		100	118.1	190.3	14.3	141.5	3.9	56.5	112.1	193.2	14.0	145.3	4.0	60.9	109.3	195.8	13.8	148.7	4.2	62.9		
		120	137.3	181.4	17.0	123.5	3.1	58.2	131.6	184.9	16.6	128.1	3.3	62.0	129.0	188.0	16.3	132.3	3.4	63.7		
90	21	60	82.1	232.1	9.5	199.7	7.2	71.0	74.6	233.9	9.3	202.1	7.4	77.4	71.2	235.6	9.2	204.3	7.5	80.3		
		80	101.2	222.6	11.8	182.3	5.5	72.6	94.1	225.1	11.6	185.6	5.7	78.4	90.8	227.4	11.4	188.6	5.9	81.0		
		100	Operation not recommended																			
		120	Operation not recommended																			
	32	60	82.7	238.5	9.6	205.9	7.3	70.4	75.0	240.4	9.4	208.3	7.5	77.0	71.5	242.1	9.2	210.6	7.7	80.0		
		80	101.8	228.7	11.9	188.2	5.6	72.1	94.5	231.3	11.7	191.5	5.8	78.0	91.1	233.6	11.5	194.6	6.0	80.7		
		100	Operation not recommended																			
		120	Operation not recommended																			
	42	60	83.3	244.3	9.6	211.4	7.4	69.9	75.4	246.2	9.5	214.0	7.6	76.6	71.8	248.0	9.3	216.3	7.8	79.7		
		80	102.3	234.3	12.0	193.4	5.7	71.6	94.8	236.9	11.7	196.9	5.9	77.7	91.4	239.3	11.5	200.0	6.1	80.5		
		100	Operation not recommended																			
		120	Operation not recommended																			

NOTE: For part load application, divide capacity by 2.

180 - Performance Data

Cooling Capacity

Source		Load Flow - 24 GPM							Load Flow - 36 GPM							Load Flow - 48 GPM						
EST °F	Flow GPM	ELT °F	LLT °F	TC MBTUH	Power kW	HR MBTUH	EER	LST °F	LLT °F	TC MBTUH	Power kW	HR MBTUH	EER	LST °F	LLT °F	TC MBTUH	Power kW	HR MBTUH	EER	LST °F		
30	24	50	35.5	173.5	6.83	196.8	25.4	46.4	40.0	180.0	6.9	203.7	26.0	47.0	42.2	186.6	7.04	210.6	26.5	47.5		
		70	52.4	211.1	7.58	237.0	27.9	49.7	57.8	219.1	7.7	245.3	28.5	50.4	60.5	227.0	7.81	253.7	29.1	51.1		
		90	69.3	248.8	8.32	277.2	29.9	53.1	75.7	258.2	8.5	287.0	30.5	53.9	78.9	267.5	8.58	296.8	31.2	54.7		
		110	86.1	286.4	9.07	317.4	31.6	56.4	93.5	297.2	9.2	328.6	32.3	57.4	97.2	308.0	9.35	339.9	32.9	58.3		
	36	50	34.6	184.8	6.5	207.0	28.4	41.5	39.3	192.0	6.6	214.6	29.0	41.9	41.7	199.3	6.7	222.2	29.7	42.3		
		70	51.2	225.2	7.23	249.9	31.1	43.9	57.0	233.9	7.3	258.9	31.8	44.4	59.9	242.5	7.46	268.0	32.5	44.9		
		90	67.9	265.6	7.94	292.7	33.4	46.3	74.7	275.7	8.1	303.2	34.2	46.8	78.1	285.8	8.19	313.7	34.9	47.4		
		110	84.5	306.0	8.7	335.5	35.3	48.6	92.4	317.5	8.8	347.5	36.1	49.3	96.3	329.0	8.9	359.5	36.9	50.0		
	48	50	33.7	196.1	6.21	217.3	31.6	39.1	38.7	204.1	6.3	225.6	32.4	39.4	41.2	212.0	6.40	233.8	33.1	39.7		
		70	50.1	239.2	6.89	262.7	34.7	40.9	56.2	248.6	7.0	272.5	35.5	41.4	59.3	258.0	7.10	282.2	36.3	41.8		
		90	66.5	282.4	7.57	308.2	37.3	42.8	73.7	293.2	7.7	319.4	38.2	43.3	77.3	304.0	7.80	330.6	39.0	43.8		
		110	82.9	325.5	8.25	353.6	39.5	44.7	91.2	337.8	8.4	366.3	40.3	45.3	95.4	350.0	8.50	379.0	41.2	45.8		
50	24	50	36.5	162.2	9.03	193.0	18.0	66.1	40.6	168.3	9.2	199.6	18.3	66.6	42.7	174.4	9.31	206.2	18.7	67.2		
		70	53.7	195.9	9.83	229.5	19.9	69.1	58.7	203.3	10.0	237.4	20.4	69.8	61.2	210.7	10.14	245.3	20.8	70.4		
		90	70.9	229.7	10.63	265.9	21.6	72.2	76.8	238.3	10.8	275.2	22.1	72.9	79.7	247.0	10.96	284.4	22.5	73.7		
		110	88.0	263.4	11.43	302.4	23.1	75.2	94.8	273.3	11.6	312.9	23.6	76.1	98.2	283.3	11.78	323.4	24.0	77.0		
	36	50	35.7	171.4	8.6	200.9	19.8	61.2	40.1	178.1	8.8	208.1	20.3	61.6	42.3	184.9	8.9	215.2	20.8	62.0		
		70	52.7	207.4	9.40	239.5	22.1	63.3	58.0	215.4	9.5	248.0	22.6	63.8	60.7	223.4	9.69	256.4	23.0	64.2		
		90	69.7	243.4	10.16	278.1	23.9	65.4	76.0	252.6	10.3	287.8	24.5	66.0	79.1	261.9	10.48	297.6	25.0	66.5		
		110	86.7	279.3	10.9	316.6	25.6	67.6	93.9	289.9	11.1	327.7	26.1	68.2	97.5	300.4	11.3	338.8	26.7	68.8		
	48	50	34.9	180.7	8.25	208.8	21.9	58.7	39.6	188.0	8.4	216.5	22.5	59.0	41.9	195.3	8.50	224.3	23.0	59.3		
		70	51.8	218.9	8.97	249.5	24.4	60.4	57.4	227.4	9.1	258.5	25.0	60.8	60.2	236.0	9.25	267.6	25.5	61.1		
		90	68.6	257.1	9.70	290.2	26.5	62.1	75.2	266.9	9.9	300.5	27.1	62.5	78.5	276.8	10.00	310.9	27.7	63.0		
		110	85.4	295.3	10.43	330.9	28.3	63.8	93.0	306.4	10.6	342.5	28.9	64.3	96.8	317.5	10.75	354.2	29.5	64.8		
70	24	50	37.4	150.9	11.24	189.2	13.4	85.8	41.3	156.6	11.4	195.5	13.7	86.3	43.2	162.3	11.59	201.8	14.0	86.8		
		70	54.9	180.7	12.09	222.0	15.0	88.5	59.6	187.5	12.3	229.4	15.3	89.1	61.9	194.3	12.46	236.9	15.6	89.7		
		90	72.5	210.6	12.94	254.7	16.3	91.2	77.9	218.5	13.1	263.3	16.6	91.9	80.6	226.4	13.34	271.9	17.0	92.7		
		110	Operation not recommended																			
	36	50	36.8	158.0	10.8	194.8	14.7	80.8	40.9	164.2	10.9	201.5	15.0	81.2	42.9	170.4	11.1	208.3	15.4	81.6		
		70	54.2	189.6	11.57	229.1	16.4	82.7	59.1	196.9	11.75	237.0	16.8	83.2	61.5	204.2	11.93	244.9	17.1	83.6		
		90	71.6	221.2	12.39	263.4	17.9	84.6	77.2	229.6	12.58	272.5	18.3	85.1	80.1	238.0	12.77	281.5	18.6	85.6		
		110	Operation not recommended																			
	48	50	36.2	165.2	10.28	200.3	16.1	78.3	40.4	171.9	10.4	207.5	16.5	78.6	42.6	178.6	10.60	214.8	16.8	78.9		
		70	53.5	198.5	11.06	236.2	17.9	79.8	58.5	206.3	11.2	244.6	18.4	80.2	61.1	214.1	11.40	253.0	18.8	80.5		
		90	70.7	231.8	11.83	272.1	19.6	81.3	76.6	240.7	12.0	281.7	20.0	81.7	79.6	249.5	12.20	291.2	20.5	82.1		
		110	Operation not recommended																			
90	24	50	38.4	139.6	13.44	185.5	10.4	105.5	42.0	144.8	13.7	191.4	10.6	106.0	43.7	150.1	13.86	197.4	10.8	106.4		
		70	56.2	165.5	14.34	214.5	11.5	107.9	60.5	171.8	14.57	221.4	11.8	108.5	62.6	178.0	14.79	228.4	12.0	109.0		
		90	74.0	191.5	15.24	243.5	12.6	110.3	79.0	198.7	15.48	251.5	12.8	111.0	81.4	205.9	15.72	259.5	13.1	111.6		
		110	Operation not recommended																			
	36	50	37.9	144.7	12.9	188.6	11.2	100.5	41.6	150.3	13.1	195.0	11.5	100.8	43.5	156.0	13.3	201.3	11.7	101.2		
		70	55.7	171.8	13.74	218.7	12.5	102.2	60.1	178.4	13.96	226.0	12.8	102.6	62.3	185.0	14.17	233.4	13.1	103.0		
		90	73.4	199.0	14.61	248.8	13.6	103.8	78.5	206.5	14.83	257.1	13.9	104.3	81.1	214.1	15.06	265.5	14.2	104.7		
		110	Operation not recommended																			
	48	50	37.5	149.8	12.32	191.8	12.2	98.0	41.3	155.8	12.5	198.5	12.5	98.3	43.3	161.9	12.70	205.2	12.7	98.6		
		70	55.2	178.1	13.14	223.0	13.6	99.3	59.7	185.1	13.35	230.6	13.9	99.6	62.0	192.1	13.55	238.3	14.2	99.9		
		90	72.8	206.5	13.97	254.1	14.8	100.6	78.1	214.4	14.18	262.8	15.1	100.9	80.7	222.3	14.40	271.4	15.4	101.3		
		110	Operation not recommended																			
110	24	50	39.3	128.3	15.65	181.7	8.2	125.1	42.6	133.1	15.9	187.3	8.4	125.6	44.3	137.9	16.13	193.0	8.6	126.1		
		70	57.5	150.3	16.60	207.0	9.1	127.2	61.3	156.0	16.86	213.5	9.3	127.8	63.3	161.6	17.11	220.0	9.4	128.3		
		90	Operation not recommended																			
		110	Operation not recommended																			
	36	50	39.1	131.3	15.0	182.5	8.8	120.1	42.4	136.4	15.2	188.4	9.0	120.5	44.1	141.6	15.5	194.3	9.2	120.8		
		70	57.2	154.0	15.91	208.3	9.7	121.6	61.1	160.0	16.16	215.1	9.9	121.9	63.1	165.9	16.41	221.9	10.1	122.3		
		90	Operation not recommended																			
		110	Operation not recommended																			
	48	50	38.8	134.3	14.36	183.3	9.4	117.6	42.2	139.8	14.6	189.5	9.6	117.9	44.0	145.2	14.80	195.7	9.8	118.2		
		70	56.9	157.7	15.23	209.7	10.4	118.7	60.9	163.9	15.46	216.7	10.6	119.0	62.9	170.1	15.70	223.7	10.8	119.3		
		90	Operation not recommended																			
		110	Operation not recommended																			

NOTE: For part load application, divide capacity by 2.

180 - Performance Data

Heating Capacity

Source		Load Flow - 24 GPM							Load Flow - 36 GPM							Load Flow - 48 GPM						
EWT °F	Flow GPM	ELT °F	LLT °F	HC MBTUH	Power kW	HE MBTUH	COP	LST °F	LLT °F	HC MBTUH	Power kW	HE MBTUH	COP	LST °F	LLT °F	HC MBTUH	Power kW	HE MBTUH	COP	LST °F		
30	36	60	72.7	152.0	9.7	119.1	4.6	20.1	68.5	153.2	9.5	120.8	4.7	23.3	66.4	154.3	9.3	122.5	4.8	24.9		
		80	92.0	143.7	12.6	100.6	3.3	21.6	88.1	145.2	12.4	102.9	3.4	24.3	86.1	146.8	12.2	105.2	3.5	25.6		
		100	111.3	135.4	15.6	82.1	2.5	23.2	107.6	137.3	15.3	85.0	2.6	25.3	105.8	139.2	15.0	87.9	2.7	26.3		
		120	130.6	127.0	18.6	63.6	2.0	24.7	127.2	129.3	18.2	67.1	2.1	26.3	125.5	131.6	17.9	70.7	2.2	27.1		
	48	60	73.0	155.9	9.7	122.7	4.7	19.8	68.7	157.1	9.6	124.5	4.8	23.1	66.6	158.3	9.4	126.2	4.9	24.7		
		80	92.3	147.4	12.7	104.0	3.4	21.3	88.3	149.0	12.5	106.3	3.5	24.1	86.3	150.5	12.3	108.7	3.6	25.5		
		100	111.6	138.8	15.7	85.2	2.6	22.9	107.8	140.8	15.4	88.2	2.7	25.1	105.9	142.8	15.1	91.1	2.8	26.2		
		120	130.9	130.3	18.7	66.4	2.0	24.5	127.4	132.6	18.4	70.0	2.1	26.1	125.6	135.0	18.0	73.6	2.2	26.9		
50	24	60	75.6	187.3	10.1	152.8	5.4	37.3	70.5	188.8	10.0	154.8	5.6	41.4	67.9	190.2	9.8	156.8	5.7	43.5		
		80	94.8	177.3	13.1	132.6	4.0	39.0	90.0	179.3	12.9	135.3	4.1	42.5	87.5	181.2	12.7	138.0	4.2	44.3		
		100	113.9	167.4	16.1	112.3	3.0	40.6	109.4	169.7	15.8	115.8	3.1	43.6	107.2	172.1	15.5	119.2	3.3	45.0		
		120	133.1	157.4	19.1	92.1	2.4	42.3	128.9	160.2	18.8	96.2	2.5	44.7	126.8	163.1	18.4	100.3	2.6	45.8		
	36	60	76.0	192.3	10.2	157.5	5.5	36.9	70.8	193.7	10.0	159.5	5.7	41.1	68.1	195.2	9.9	161.6	5.8	43.3		
		80	95.2	182.0	13.2	136.9	4.0	38.6	90.2	184.0	13.0	139.7	4.2	42.2	87.7	185.9	12.7	142.4	4.3	44.1		
		100	114.3	171.8	16.2	116.3	3.1	40.3	109.7	174.2	15.9	119.8	3.2	43.3	107.4	176.6	15.6	123.3	3.3	44.9		
		120	133.5	161.5	19.3	95.8	2.5	42.0	129.1	164.4	18.9	100.0	2.6	44.4	127.0	167.4	18.5	104.2	2.6	45.7		
	48	60	76.4	197.2	10.3	162.1	5.6	36.5	71.0	198.7	10.1	164.2	5.8	40.9	68.3	200.2	9.9	166.3	5.9	43.1		
		80	95.6	186.7	13.3	141.2	4.1	38.2	90.5	188.7	13.1	144.0	4.2	42.0	87.9	190.7	12.8	146.9	4.4	43.9		
		100	114.7	176.2	16.4	120.3	3.2	40.0	109.9	178.7	16.1	123.9	3.3	43.1	107.5	181.2	15.8	127.4	3.4	44.7		
		120	133.8	165.7	19.4	99.4	2.5	41.7	129.4	168.7	19.0	103.7	2.6	44.2	127.2	171.7	18.7	108.0	2.7	45.5		
70	24	60	78.9	226.5	10.7	190.1	6.2	54.2	72.7	228.3	10.5	192.5	6.4	59.3	69.6	230.0	10.3	194.8	6.5	61.9		
		80	97.9	214.7	13.7	167.9	4.6	56.0	92.1	217.0	13.5	171.0	4.7	60.5	89.1	219.3	13.2	174.2	4.9	62.7		
		100	116.9	202.8	16.8	145.7	3.5	57.9	111.4	205.7	16.4	149.6	3.7	61.7	108.7	208.6	16.1	153.6	3.8	63.6		
		120	135.9	191.0	19.8	123.4	2.8	59.7	130.8	194.5	19.4	128.2	2.9	62.9	128.2	197.9	19.0	132.9	3.0	64.5		
	36	60	79.4	232.5	10.8	195.8	6.3	53.7	73.0	234.3	10.6	198.2	6.5	59.0	69.8	236.0	10.4	200.6	6.7	61.6		
		80	98.4	220.3	13.8	173.2	4.7	55.6	92.4	222.7	13.6	176.4	4.8	60.2	89.4	225.1	13.3	179.6	5.0	62.5		
		100	117.3	208.2	16.9	150.6	3.6	57.5	111.7	211.1	16.6	154.6	3.7	61.4	108.9	214.1	16.3	158.6	3.9	63.4		
		120	136.3	196.0	20.0	127.9	2.9	59.3	131.1	199.6	19.6	132.8	3.0	62.6	128.5	203.1	19.2	137.7	3.1	64.3		
	48	60	79.9	238.5	10.8	201.5	6.5	53.2	73.3	240.3	10.6	203.9	6.6	58.7	70.1	242.1	10.5	206.4	6.8	61.4		
		80	98.8	226.0	13.9	178.5	4.8	55.1	92.7	228.4	13.7	181.8	4.9	59.9	89.6	230.8	13.4	185.0	5.0	62.3		
		100	117.8	213.5	17.0	155.5	3.7	57.0	112.0	216.6	16.7	159.6	3.8	61.1	109.1	219.6	16.4	163.7	3.9	63.2		
		120	136.8	201.0	20.1	132.4	2.9	59.0	131.4	204.7	19.7	137.4	3.0	62.4	128.7	208.3	19.3	142.4	3.2	64.1		
90	24	60	82.1	265.8	11.2	227.5	6.9	71.0	74.9	267.8	11.0	230.2	7.1	77.2	71.2	269.8	10.8	232.8	7.3	80.3		
		80	101.0	252.0	14.3	203.2	5.2	73.1	94.2	254.7	14.0	206.8	5.3	78.5	90.7	257.5	13.8	210.4	5.5	81.2		
		120	Operation not recommended																			
	36	60	82.7	272.7	11.3	234.2	7.1	70.5	75.3	274.8	11.1	236.9	7.3	76.8	71.5	276.9	10.9	239.6	7.4	80.0		
		80	101.6	258.7	14.4	209.5	5.3	72.5	94.5	261.4	14.2	213.2	5.4	78.2	91.0	264.2	13.9	216.8	5.6	81.0		
		100	Operation not recommended																			
		120	Operation not recommended																			
	48	60	83.3	279.7	11.4	240.9	7.2	69.9	75.7	281.9	11.2	243.7	7.4	76.5	71.8	284.0	11.0	246.5	7.6	79.7		
		80	102.1	265.3	14.5	215.7	5.4	72.0	94.9	268.2	14.3	219.5	5.5	77.8	91.3	271.0	14.0	223.2	5.7	80.7		
		100	Operation not recommended																			
		120	Operation not recommended																			

NOTE: For part load application, divide capacity by 2.

Wiring Schematics cont.

208-230/60/1 Supply Power HydroZone continued

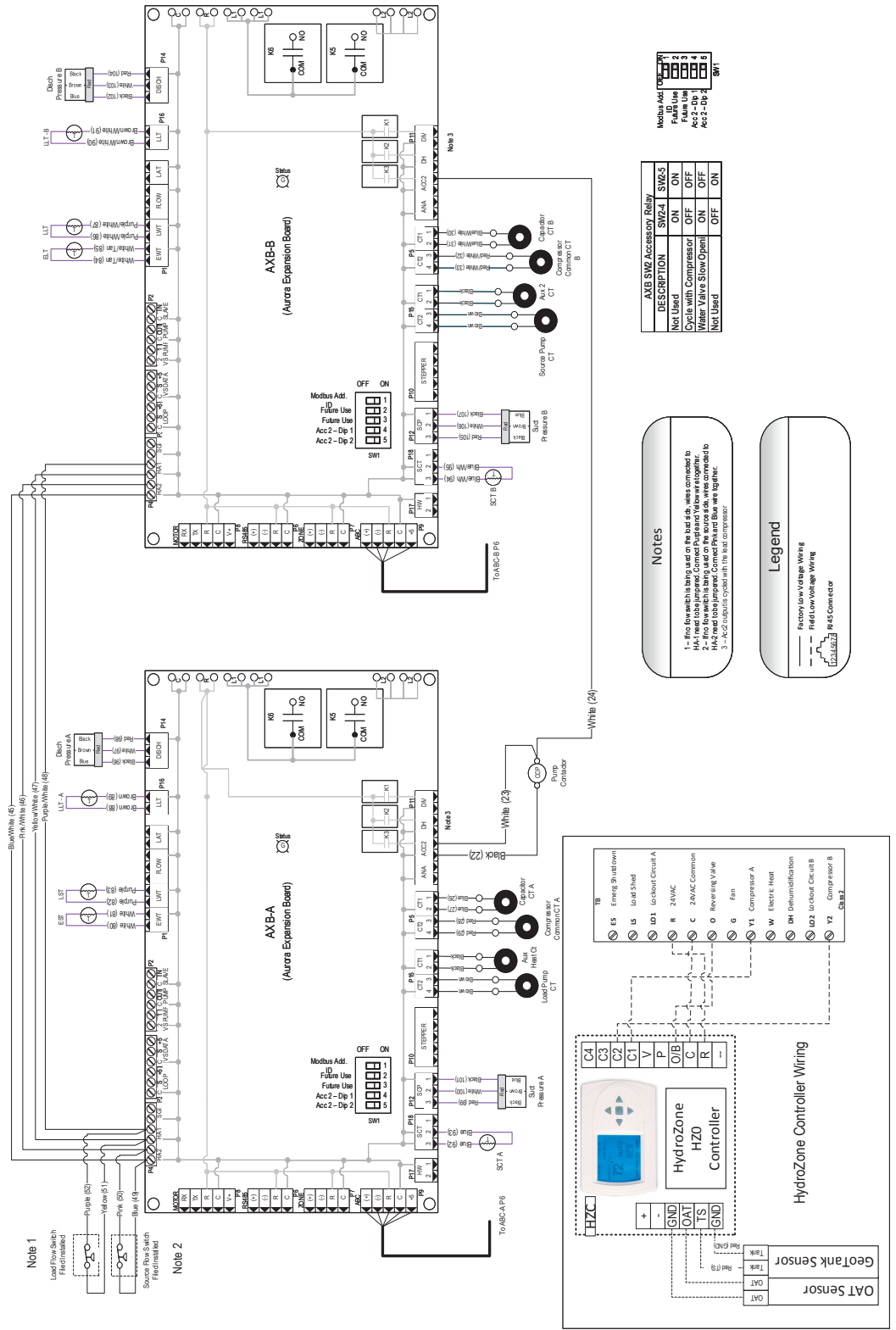

Wiring Schematics cont.

208-230/60/1 Supply Power with HydroZone continued

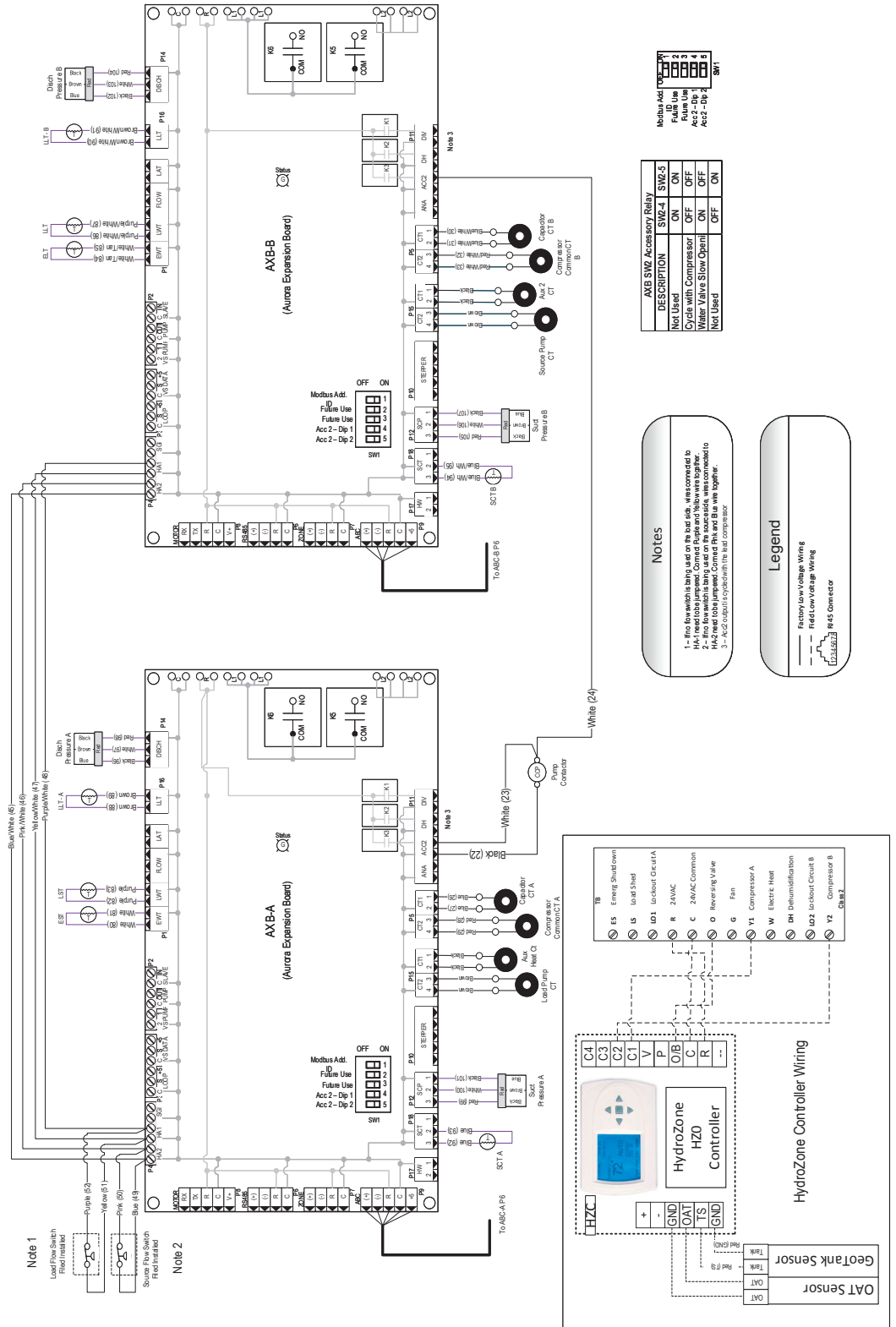

Wiring Schematics cont.

3PH Supply Power with HydroZone

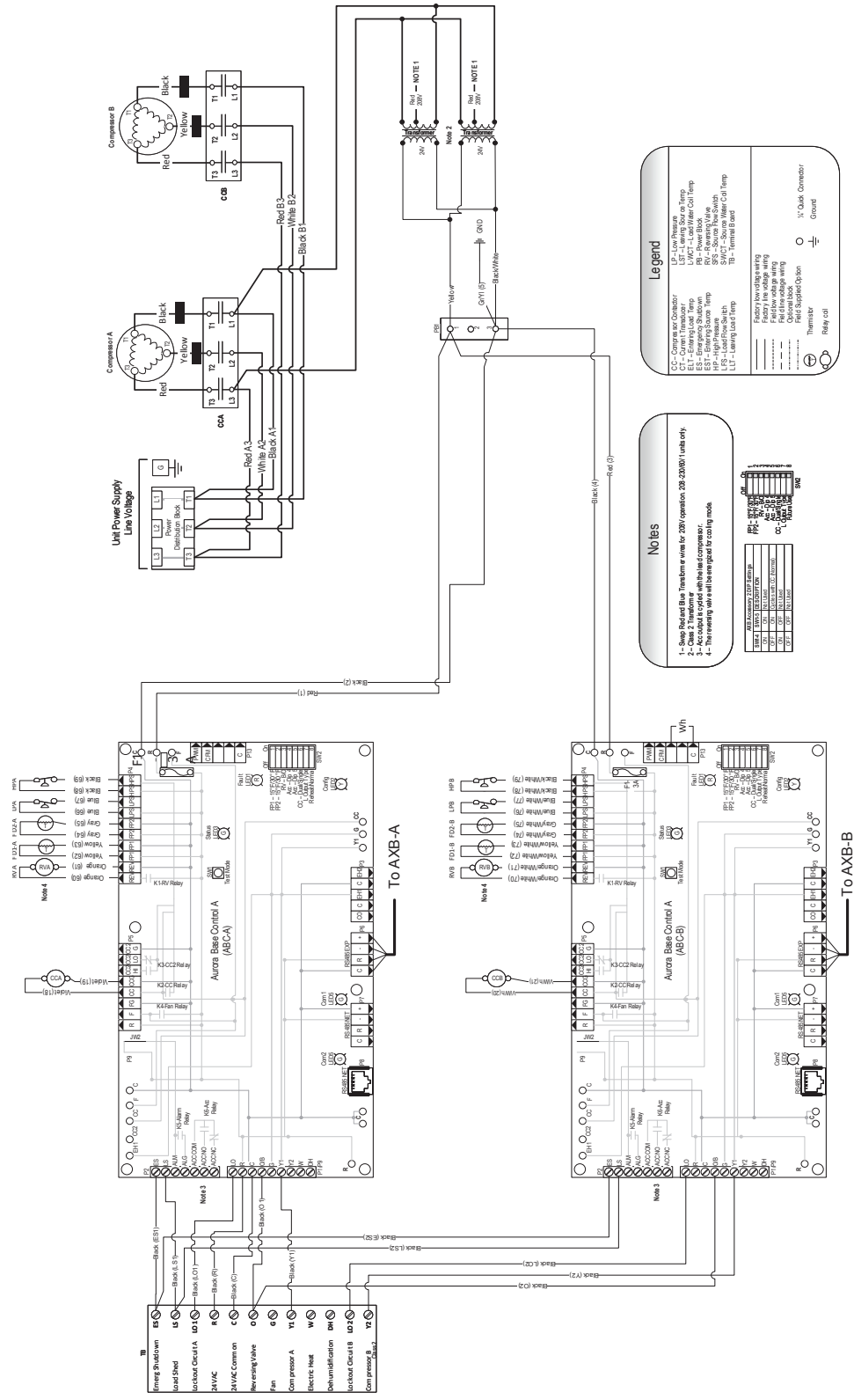

Wiring Schematics cont.

3PH Supply Power with HydroZone continued

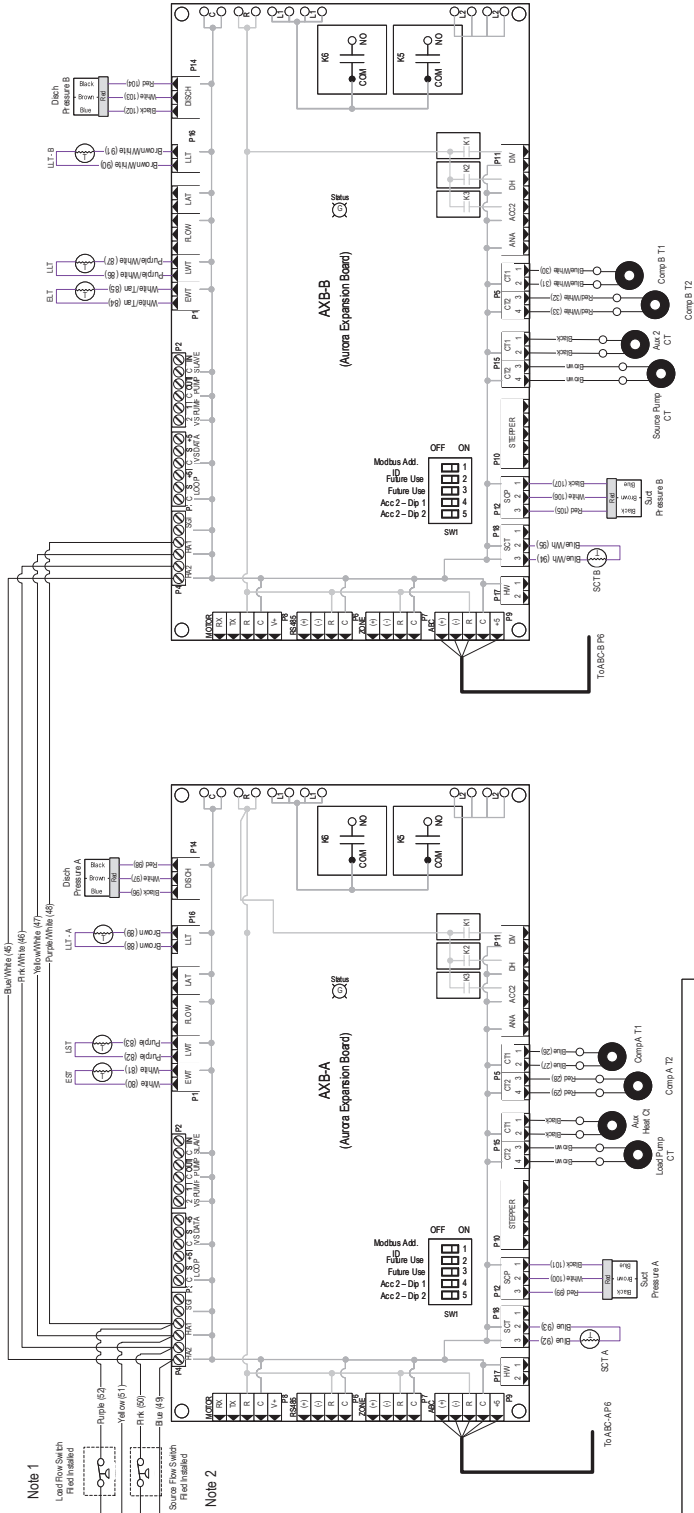

Note 1
Load Flow Switch
Red (R50)
Blue (B50)
Yellow (Y50)
Black (B49)
White (W49)
Purple (P49)

Note 2
Source Flow Switch
Red (R50)
Blue (B50)
Yellow (Y50)
Black (B49)
White (W49)
Purple (P49)

Modbus Adr.	SW1
1	1
2	2
3	3
4	4
5	5

AXB SWZ Accessory Relay	SWZ-4	SWZ-5
DESCRIPTION	ON	ON
Not Used	OFF	OFF
Cycle with Compressor	ON	OFF
Water Valve Slow Open	ON	OFF
Not Used	OFF	ON

Notes

1 - If no flow switch is being used on the load side, wires connected to it are not to be jumped. Connect Purple and White together. If a flow switch is being used, connect Purple and White together. If a flow switch is being used, connect the red and blue wires together.

Legend

- Factory Low Voltage Wiring
- Field Low Voltage Wiring
- 485 Connector

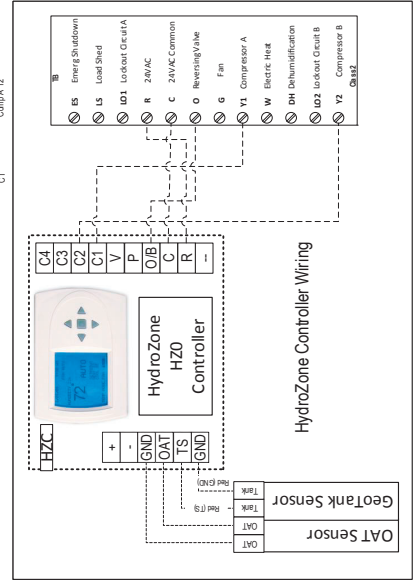

Wiring Schematics cont.

100-180 208-230/60/1 with HydroLink continued

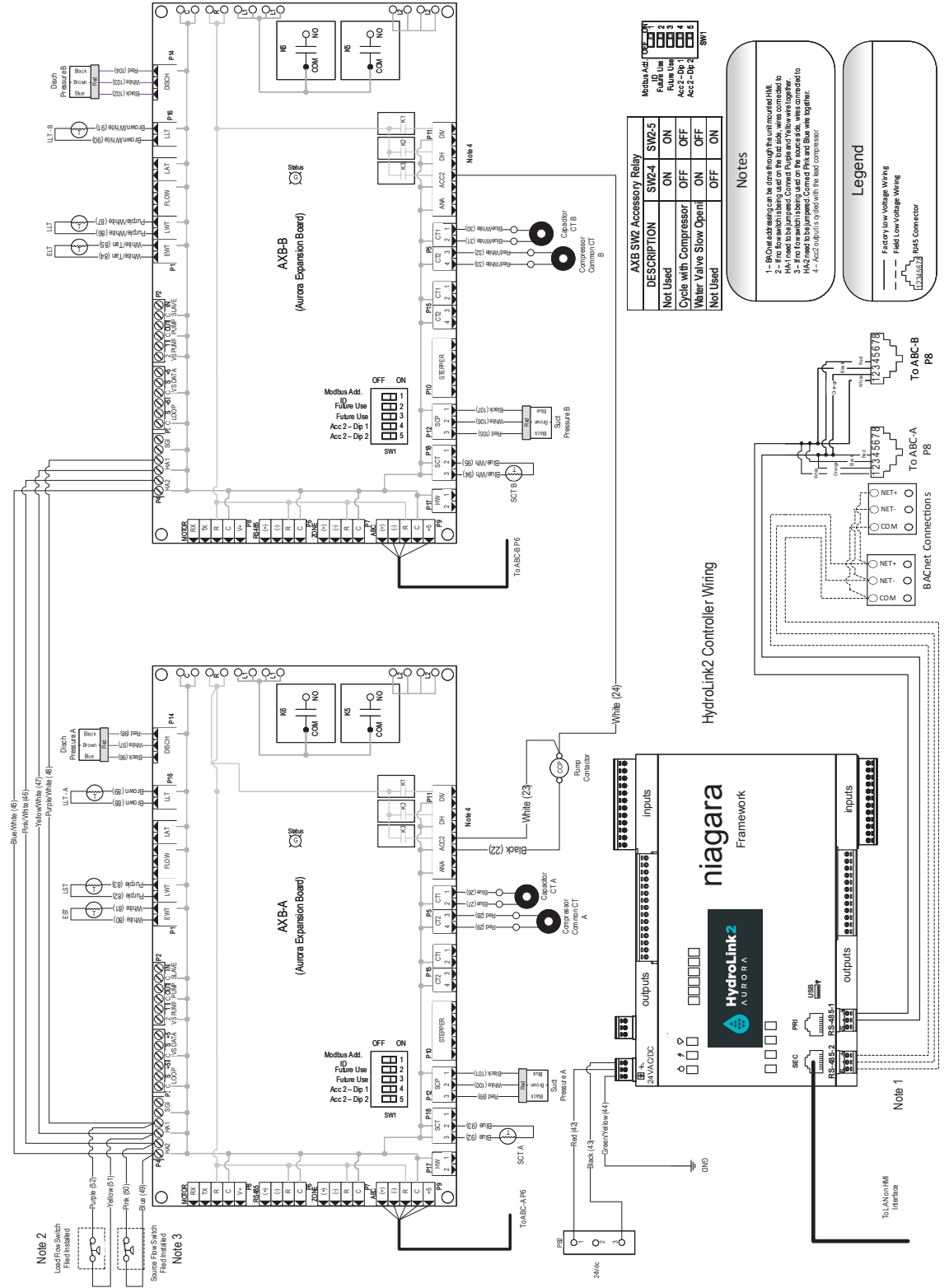

AXB SWZ Accessory Relay	SWZ-4	SWZ-5
DESCRIPTION	ON	ON
Not Used	OFF	OFF
Cycle with Compressor	OFF	OFF
Water Valve Slow Open	ON	OFF
Not Used	OFF	ON

No tes

1 - BACnet addressing can be done through the unpopulated IHLK.
 2 - Fire flow switch labeling used on the bus side, wire connected to the fire flow switch.
 3 - Fire flow switch common pump and fire side wire together to IHLK.
 4 - Acc2 input is cycled with the lead compressor.

Legend

Field Low Voltage Wiring
 Field Low Voltage Wiring
 BACnet Connections

HydroLink2 Controller Wiring

Wiring Schematics cont.

3PH Supply Power HydroLink

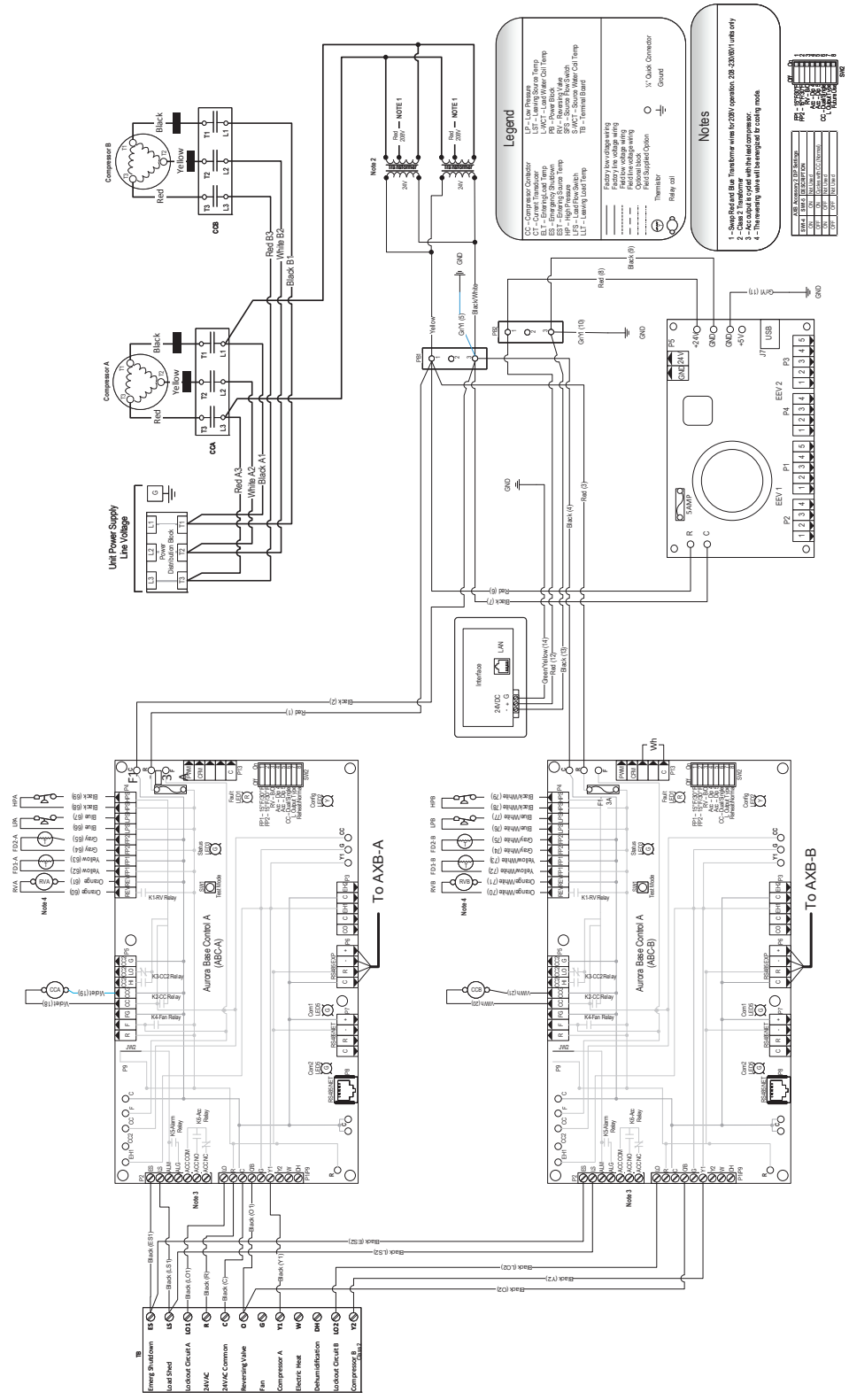

Wiring Schematics cont.

3PH Supply Power HydroLink continued

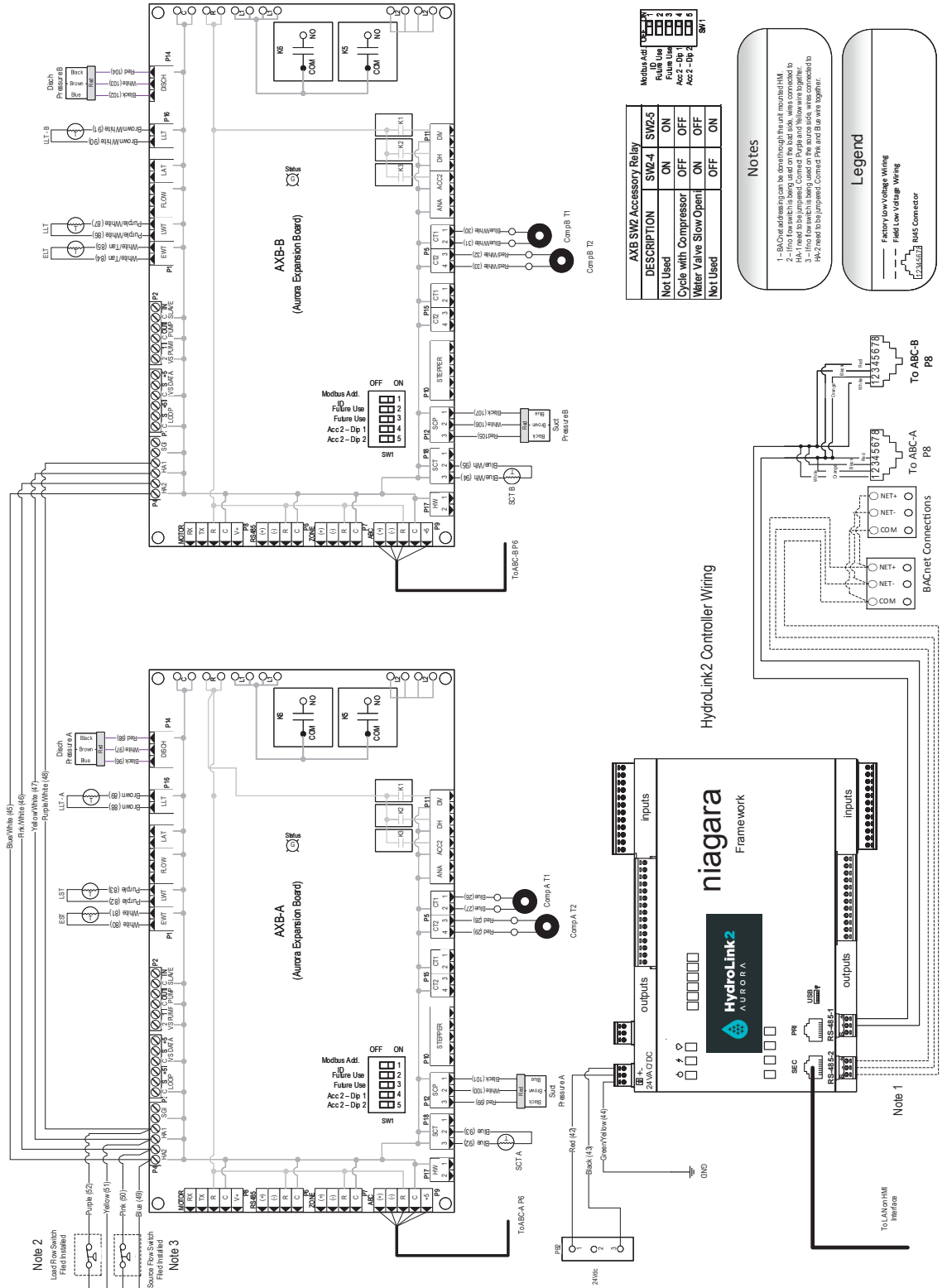

Note 2
Load Flow Switch
Filed In/Blank

Note 3
Source Flow Switch
Filed In/Blank

AXB SWZ Accessory Relay	SWZ-4	SWZ-5
DESCRIPTION	ON	ON
Not Used	OFF	OFF
Cycle with Compressor	OFF	OFF
Water Valve Slow Open	OFF	ON
Not Used	OFF	ON

Notes

- 1 - BACnet address can be done through the unit mounted HIM
- 2 - Flow switch is being used on the bad side, was connected to HIM 1 need to be replaced. Contact Future and follow together to HIM 2 need to be replaced. Contact Pike and B on wire together.

Legend

- Factory Low Voltage Wiring
- Field Low Voltage Wiring
- HMS Connector

HydroLink2 Controller Wiring

Note 1

Accessories and Options

Flow Proving Switch

The FPS300 flow switch is designed to detect the presence or absence of flow in the piping of a water source heat pump. In water source heat pumps the flow switch is normally used to shut off the compressor whenever there is not circulation of the brine solution through the braze plate or coaxial heat exchanger. A lack of circulation can damage braze plate or coaxial heat exchangers if freezing occurs.



Load and Source Piping Connections

The Two-Stage Hydronic Series has two connection options available. Each kit is intended to connect one piping connection. Therefore, two kits will be required for each unit. The kits can be mixed for installer convenience, one on source and the other on load.

CKNDW1 - Strainer Connection Kit includes a 2 in. copper tee with integral P/T plug and a 2 in. "Y" strainer. Other components to complete the all copper piping can be sourced locally.

WFI-XYH200-F-24MO-M - Strainer Hose Kit set includes a 2 in. stainless steel braided hose with integral P/T plug and a 2 in. "Y" strainer.

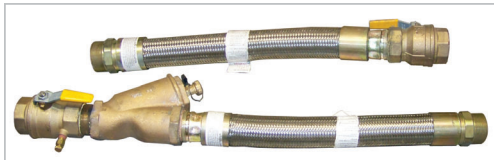

WFI-XYH200-F-24MO-M



CKNDW1

Strainers

All units shall have a field-installed 2 in. Y-strainer with a self-aligning screen and 1 in. blow-off port to reduce debris that will enter the condenser/evaporator. Strainers should be made of a brass body with a 316 stainless steel 20-40 mesh screen.



 **WARNING: Warranty is void if strainers are not used on the entering side of the load and source.**

Earth Loop and Load-side Pump Kits (Field Installed)

A specially designed one or two-pump module provides all liquid flow, fill and connection requirements for independent single unit systems (230/60/1 only).

Calculate the system pressure drop then refer to the pump curves to select the proper pump. All of the pump kits can be used for hydronic heating applications as long as they meet the flow requirements. If the flow requirements are outside the pump curve, an alternate pump will need to be obtained to maintain the necessary flow.

FCM2-3023 - UPS60-150 (x2), cast iron pump volute, 3-speed, 2 in. full-port

FCL1-5028 - UPS32-160, cast iron pump volute, 3-speed, 2 in. full-port

FCL1-5038 - UPS40-160, cast iron pump volute, 3-speed, 2 in. full-port

FCL1-5055 - UPS40-240, cast iron pump volute, 3-speed, 2 in. full-port

HydroZone Tank Controller

Tank controller (**HZO**) that adds outdoor reset with warm weather shutdown, setpoint control, process control, and management of four compressor outputs for our water-to-water systems.

HZAB

This is used in conjunction with the HydroZone to control the Geo-Storage tank electric heating element.

Accessories and Options cont.

Pump Curve - FCM2-3023

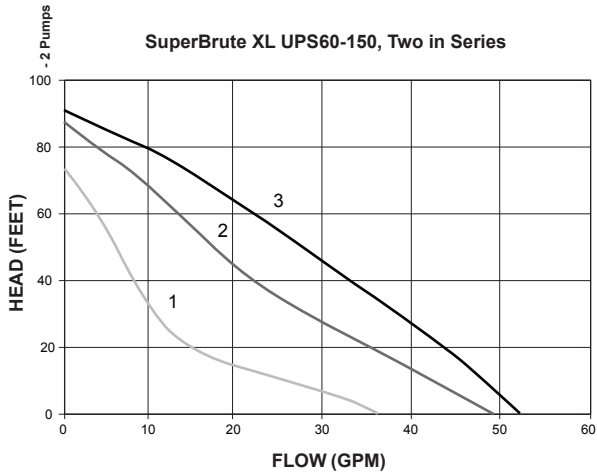

Pump Curve - FCL1-5028

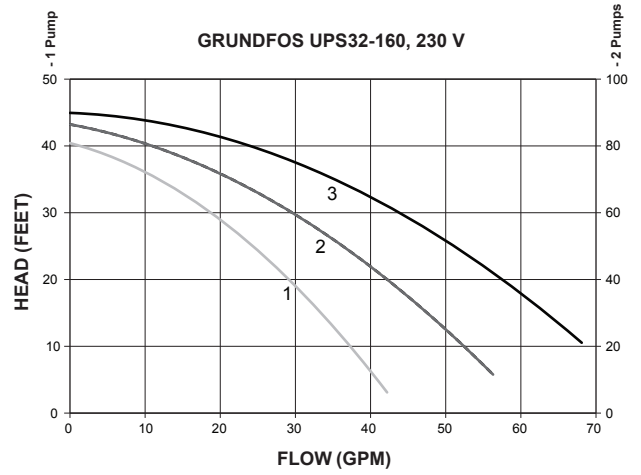

Pump Curve - FCL1-5038

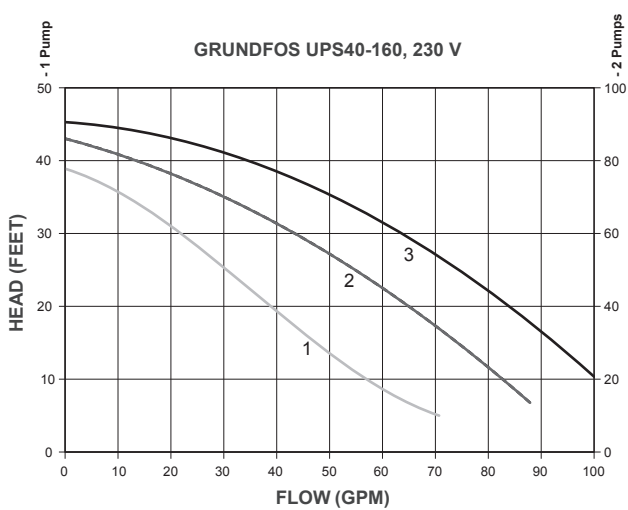

Pump Curve - FCL1-5055

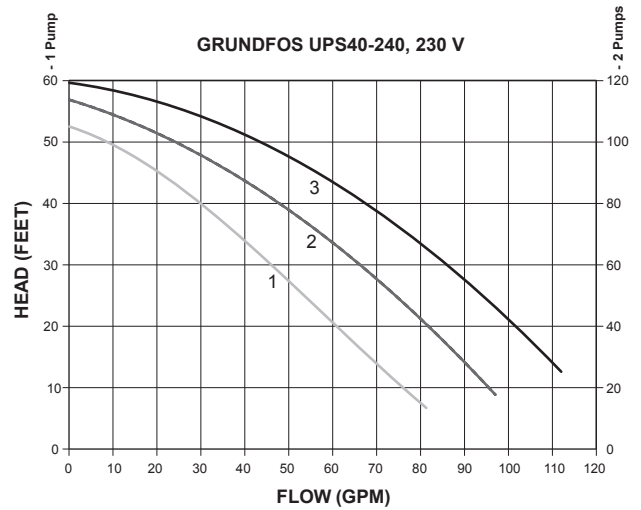

Accessories and Options cont.

Geothermal Storage Tank

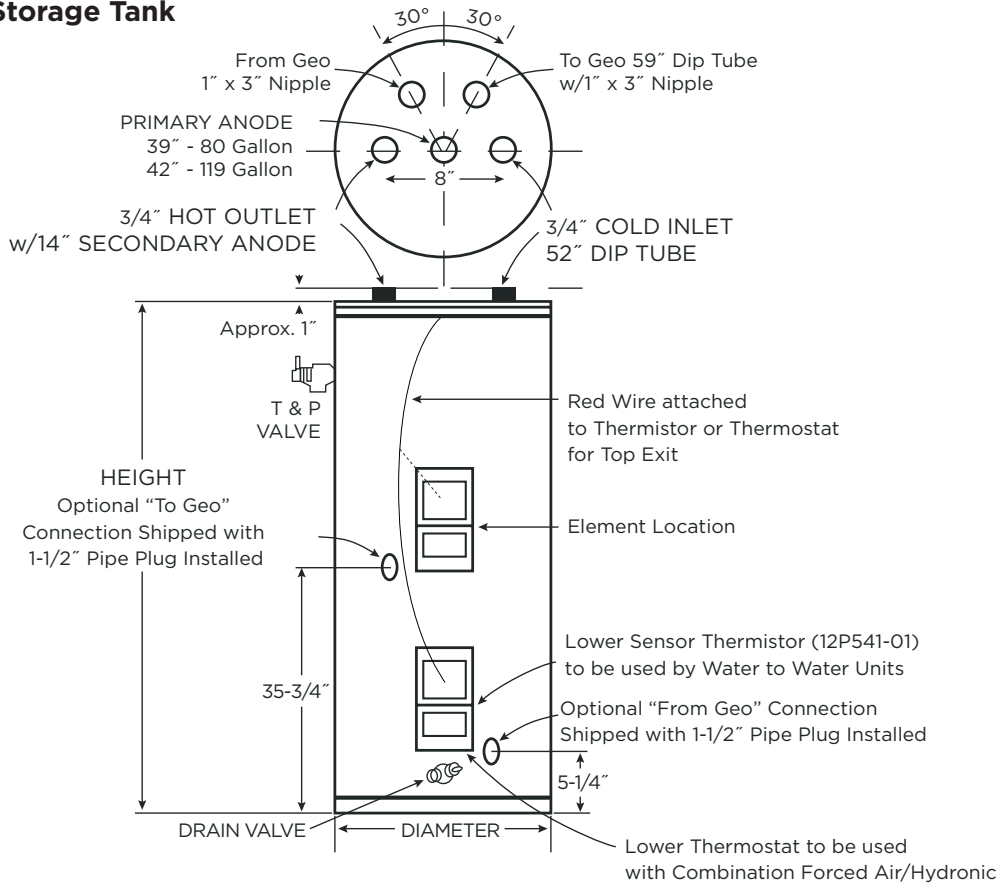

MODEL NUMBER	GALLON CAPACITY	ELEMENT WATTAGE (240 VOLT)	NUMBER OF ELEMENTS	R VALUE	DIMENSIONS IN INCHES		APPROX. SHIPPING WEIGHT (lbs.)
					HEIGHT	DIAMETER	
GEO-STORAGE-80	80	4500	1	16	63-1/4	24	204
GEO-STORAGE-120	119	4500	1	16	63-1/4	28	311

Engineering Guide Specifications

General

The liquid source water-to-water heat pump shall be a single packaged reverse-cycle heating/cooling unit. The unit shall be listed by a nationally recognized safety-testing laboratory or agency, such as ETL Testing Laboratory, Underwriters Laboratory (UL), or Canadian Standards Association (CSA). The unit shall be rated in accordance with Air Conditioning, Heating, and Refrigeration Institute/International Standards Organization (AHRI/ISO) and Canadian Standards Association (CSA-US). The liquid source water-to-water heat pump unit, shall be designed to operate with source liquid temperatures between 30°F [1.1°C] and 110°F [43.3°C] in cooling, and between 20°F [-6.7°C] and 90°F [32.2°C] in heating.

Casing and Cabinet

The cabinet shall be fabricated from heavy-gauge galvanized steel and finished with corrosion-resistant powder coating. This corrosion protection system shall meet the stringent 1,000 hour salt spray test per ASTM B117. The interior shall be insulated with 1/2" thick, multi-density, coated glass fiber for noise suppression.

The control box shall have separate holes and knockouts for entrance of line voltage and low voltage control wiring. All factory-installed wiring passing through factory knockouts and openings shall be protected from sheet metal edges at openings by plastic ferrules. The control box has a factory mounting option of being installed in the front or back (waterline side) of the unit.

Refrigerant Circuit

All units shall contain two (2) sealed refrigerant circuits, each containing a hermetic motor scroll compressor, bidirectional thermal expansion valve assemblies, reversing valve, braze plate heat exchangers, factory installed high and low pressure safety switches, freeze detection, service ports, and liquid line filter dryers. Compressors shall be scroll types designed for heat pump duty with internal isolation and mounted on rubber vibration isolators. Compressor motors shall have internal overload protection. A high density sound attenuating blanket shall be factory installed around the compressor to reduce sound. The water to refrigerant heat exchangers shall be interlaced copper brazed, 316 stainless plate steel, capable of withstanding 650 psig [4489 kPa] working pressure on the refrigerant side and 450 psig [3108 kPa] on the water side. The thermal expansion valve (TXV) shall provide proper superheat over the liquid temperature range with minimal "hunting." The assembly shall operate

bidirectionally without the use of check valves. Externally mounted pressure controlled water regulating flow valves are not acceptable.

Piping and Connections

Supply and return water connections shall be 2 in. [50.8 mm] FPT copper fittings fixed to the cabinet by use of a captive fitting, which eliminates the need for backup pipe wrenches.



Optional Back/Top Mount Water Connections - shall be factory installed to the back corner post or top panel by use of a captive fitting, which eliminates the need for backup pipe wrenches.

WARNING: Warranty is void if strainers are not used on the entering side of the load and source.

Electrical

Controls and safety devices will be factory wired and mounted within the unit. Controls shall include 24 Volt activated compressor contactors, 24VAC-75VA transformers with built in circuit breaker, reversing valve coils, and anti short-cycle protection. A terminal block with screw in terminals will be provided for field control wiring. To prevent short cycling when the safety controls are activated, the reset relay shall provide a lockout circuit that requires resetting of low voltage supply or main circuit breaker. A lockout signal shall be provided to the display to indicate a lockout situation. Units shall be name-plated for use with time delay fuses or HACR circuit breakers. Unit controls shall be 24 Volt and provide heating or cooling as required by the remote thermostat/sensor.

Optional IntelliStart (Compressor Soft Starter) - shall be factory installed for use in applications that require low starting amps, reduced compressor start-up noise, off-grid, and improved start-up behavior. IntelliStart shall reduce normal starting current by 60% on 208/60/1 units.

Engineering Guide Specifications cont.

Microprocessor Control

An Aurora, a microprocessor-based controller, interfaces with an external control to monitor and control unit operation. The unit control shall provide operational sequencing, high and low pressure switch monitoring, freeze detection, lockout mode control, load and loop pump control, LED status and fault indicators, fault memory, field selectable options, and accessory output. The Lockout signal output shall have a pulsed option so that DDC systems can read specific lockout conditions from the control.

The Aurora Advanced Control shall also feature an Energy Monitoring Package that will provide real time total power consumption, compressor monitoring, On Peak input signal for utility controlled demand programs, Performance and Refrigerant Monitoring kits to provide real time data including refrigerant superheat.

An optional Aurora Interface Diagnostic (AID) Tool shall communicate with the Aurora control allowing quick and easy access to monitoring, and troubleshooting of any Aurora control. The device shall include the features fault description and history, manual operation capability, sensor readings, timings, and other diagnostic tools. Optional IntelliStart® (compressor Soft Starter) shall be factory installed for use in applications that require low starting amps, reduced compressor start-up noise, off-grid, and improved start-up behavior. IntelliStart shall reduce normal starting current by up to 60%.

Accessories

Flow Proving Switch

WaterFurnace P/N - FPS300

A flow proving switch shall be available utilizing high reliability flow sensing technology.

Flow Meter Kit

Waterfurnace P/N NDWFMK

A flow meter shall be available utilizing vortex shredding behind a bluff body technology.

Strainer Connection Kit

WaterFurnace P/N - CKNDW1

A strainer connection kit shall be available and includes a 2 in. [50.8 mm] Y-strainer with self-aligning screen and 1 in. [25.4 mm] blow-off port to reduce debris that will enter the heat exchanger. Strainers should be made of a brass body with a 316 stainless steel screen. Connection kit shall also include a 2 in. [50.8 mm] wrought copper tee with integral pressure/temperature port.

Strainer Hose Kit Set

WaterFurnace P/N - WFI-XYH200-F-24MO-M

A strainer hose kit set shall be available and includes a 2 in. strainer loaded with 20-40 mesh screen and blow down valve, 2 in. stainless steel braid hose, 2 in. ball valve with integral pressure/temperature port and a JIC swivel fitting on the supply and 2 in. stainless steel braid hose and 2 in. ball valve with integral pressure/temperature port and a JIC swivel fitting on the return hose. The hose kit assembly shall be pressure rated at 300 psi working pressure.

NOTE: A strainer kit is required on both sides to reduce heat exchanger fouling and potential damage.

Revision Guide

Pages:	Description:	Date:	By:
29	Updated Factory Charge in Physical Data	17 Jan 2023	MA
Misc.	Remove FX10, Update for "A" Revision	29 Nov 2020	JM
4	Updated Nomenclature to Reflect 3-Phase IntelliStart Availability	18 Mar 2013	DS
11-14	Updated Controls Section	18 Mar 2013	DS
26	Updated Electrical Data to Reflect 3-Phase IntelliStart Availability	18 Mar 2013	DS
30-37	Updated Heating Performance Data	18 Mar 2013	DS
47	Added Revision Guide	18 Mar 2013	DS



Manufactured by
WaterFurnace International, Inc.
9000 Conservation Way
Fort Wayne, IN 46809
www.waterfurnace.com



SC1007WNA 01/23

Product:	Envision NDW
Type:	Hydronic Heat Pump
Size:	8-15 Tons
Document:	Specification Catalog