

SYNERGY3D

Geothermal Heat Pump with Water Heating for Radiant Floor Applications

- R-410A Refrigerant
- 3, 4, 5, 6 Ton Dual Capacity

Installation Information

Water Piping Connections

Hot Water Generator Connections

Electrical

Startup Procedures

Troubleshooting

Preventive Maintenance



Table of Contents

Model Nomenclature	4
General Installation Information	5
Closed Loop Ground Source Systems	9
Open Loop Ground Water Systems	10
Hot Water Generator Connections	11
Typical Buffer Tank Installation	11
Hydronic Section	12
Electrical Connections	14
Electronic Thermostat Installation	15
Auxiliary Heat	16
Electrical and Blower Performance Data	17
Dimensional Data	18
Physical Data	20
Microprocessor Control	21
Operation Logic	25
Wiring Schematics	26
Unit Startup	30
Operating Parameters	31
Pressure Drop	32
Compressor and Thermistor Resistance	33
Heat of Extraction/Rejection	34
Antifreeze Corrections	35
Correction Factor Tables	36
Operating Limits, Reference Calculations, Legend and Notes	37
Troubleshooting	38
Startup and Troubleshooting Form	39
Heating and Cooling Analysis	40
Hot Water Cycle Analysis	41
Preventative Maintenance and Replacement Procedures	42
Service Parts List	43
Revision Guide	44

Model Nomenclature

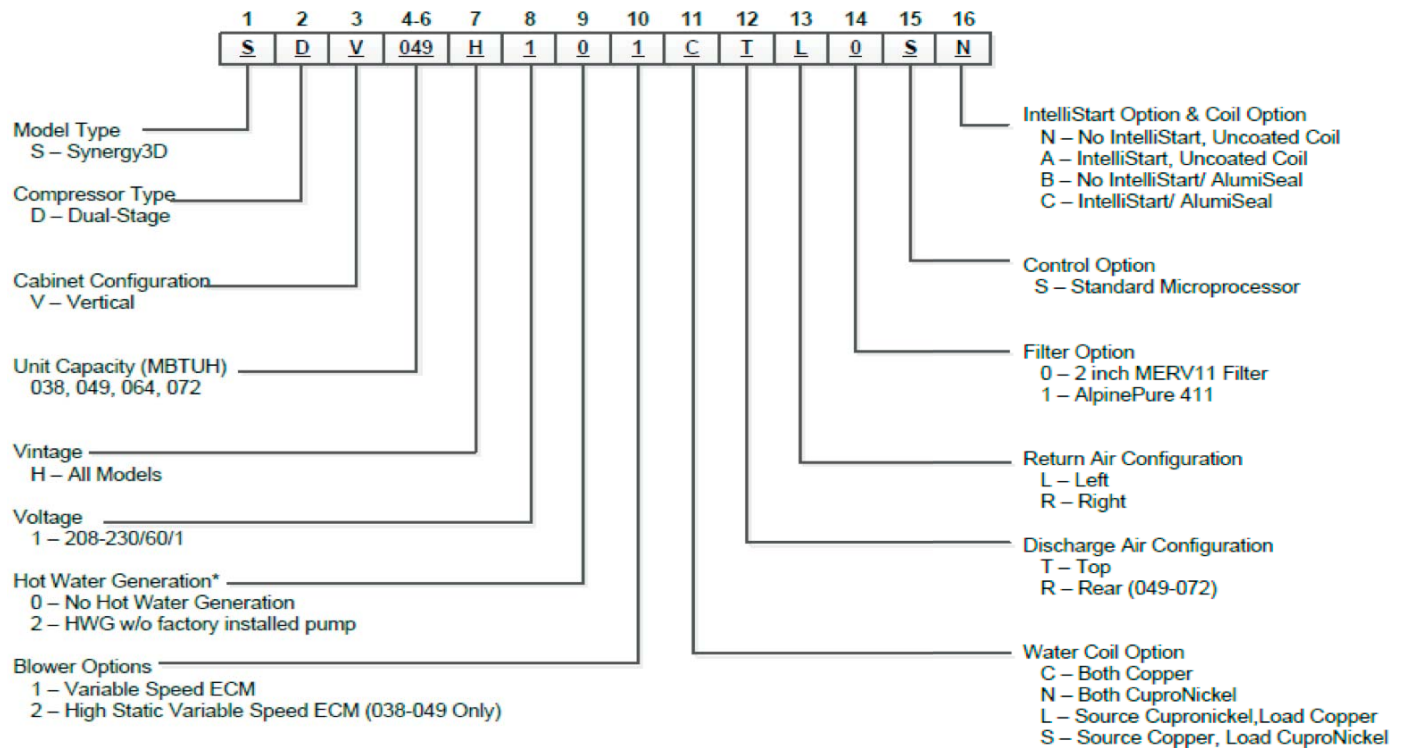

Notes:

*The factory installed Hot Water option (hot water generator) does not include a factory mounted circulating pump or temperature control. Kit DPK5 (ordered separately) includes field installed circulator, hot water tank adaptor, temperature limit and installation instructions.

Rev.: 2/8/2017

General Installation Information

Safety Considerations

Installation and servicing of heating and air conditioning equipment can be hazardous due to system pressure and electrical components. Only trained and qualified service personnel should install, repair or service heating and air conditioning equipment.

Untrained personnel can perform basic maintenance functions of cleaning coils and cleaning and replacing filters. All other operations should be performed by trained service personnel. When working on air conditioning equipment, observe precautions in the literature, tags and labels attached to the unit and other safety precautions that may apply.

Follow all safety codes. Wear safety glasses and work gloves. Use quenching cloth for brazing operations. Have fire extinguisher available for all brazing operations.



WARNING: Before performing service or maintenance operations on the system, turn off main power switches to the unit. Turn off accessory heater power switch if applicable. Electrical shock could cause serious personal injury.

Moving and Storage

Move units in the normal “Up” orientation. Vertical units are not to be moved, but may be stored one upon another to a maximum height of two units. When the equipment is received, all items should be carefully checked against the bill of lading to be sure all crates and cartons have been received. Examine units for shipping damage, removing the units from the packaging if necessary. Units in question should also be internally inspected. If any damage is noted, the carrier should make the proper notation on the delivery receipt, acknowledging the damage.

Unit Location

Locate the unit in an indoor area that allows easy removal of the filter and access panels, and has enough space for service personnel to perform maintenance or repair. Provide sufficient room to make water, electrical and duct connection(s). If the unit is located in a confined space, such as a closet, provisions must be made for return air to freely enter the space by means of a louvered door, etc. **Care should be taken when units are located in unconditioned spaces to prevent damage from frozen water lines and excessive heat that could damage electrical components.**



CAUTION: A minimum of 24 in. clearance should be allowed for access to front access panel.

Filter Rack Conversion

A 2 in. MERV 11 filter is shipped with the heat pump. To field convert the filter rack to use 1 in. filters, simply insert the provided plastic push pins into the holes located in the filter rack. There are holes on the top and bottom of the rack, underneath the instruction labels, for field conversion to 1 in. filters.

Setting Vertical Units

Prior to setting the unit in place, remove and discard the compressor hold down shipping bolt located at the front of the compressor mounting bracket.

Vertical Unit Mounting

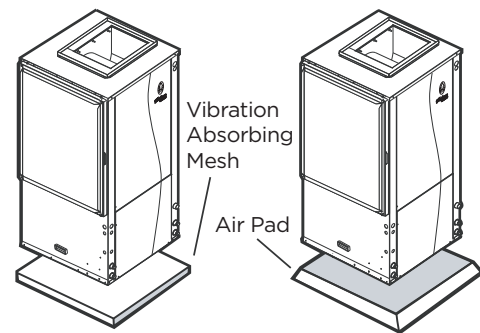

Vertical units are available in left or right hand return configuration. Vertical units should be mounted level on a vibration absorbing pad slightly larger than the base to provide isolation between the unit and the floor. It is not necessary to anchor the unit to the floor (See Vertical Unit Mounting illustration).

Duct System

An air outlet collar is provided on vertical top flow units to facilitate a duct connection, which is shipped inside the unit. A flexible connector is recommended for discharge and return air duct connections on metal duct systems. Uninsulated duct should be insulated with a minimum of 1 in. duct insulation. Application of the unit to uninsulated ductwork in an unconditioned space is not recommended as the unit's performance will be adversely affected.

If the unit is connected to existing ductwork, a previous check should have been made to assure that the duct has the capacity to handle the air required for the unit application. If ducting is too small, as in the replacement of heating only systems, larger ductwork should be installed. All existing ductwork should be checked for leaks and repaired when necessary.

General Installation Information cont.

The duct system should be sized to handle the design airflow quietly. To maximize sound attenuation of the unit blower, the supply and return plenums should include internal duct liner of glass fiber or be of ductboard construction for the first few feet. If air noise or excessive airflow is a problem, the blower speed can be changed. See the Blower Performance and Blower Speed sections.

Water Piping

The proper water flow must be provided to each unit whenever the unit operates. To assure proper flow, use pressure/temperature ports to determine the flow rate. These ports should be located at the supply and return water connections on the unit. The proper flow rate cannot be accurately set without measuring the water pressure drop through the refrigerant-to-water heat exchanger.

All Synergy3D source water connections are swivel piping fittings that accept a 1 in. Male Pipe Thread (MPT) (see Female Locking Ring illustration). The swivel pipe connector has a rubber gasket seal similar to a garden hose gasket, which when mated to the flush end of 1 in. threaded pipe provides a leak-free seal without the need for thread sealing tape or compound. Check to ensure that the rubber seal is in the swivel connector prior to attempting any connection. The rubber seals are shipped attached to the water line.

To make the connection to a ground loop system, mate the brass connector (supplied in CK4LI and CK4L-GLI connector kits) against the rubber gasket in the swivel connector, and thread the female locking ring onto the pipe threads, while maintaining the brass connector in the desired direction (see Female Locking Ring illustration). Tighten the connectors by hand and then gently snug the fitting with pliers to provide a leak proof joint. When connecting to an open loop (ground water) system, thread 1 in. MPT fitting (schedule 80 PVC or copper) into the swivel connector and tighten in the same manner as noted above. The open and closed loop piping system must include pressure/temperature taps for serviceability.

Never use flexible hoses smaller than 1 in. inside diameter on the unit and limit hose length to 10 ft. per connection. Check carefully for water leaks.

Female Locking Ring

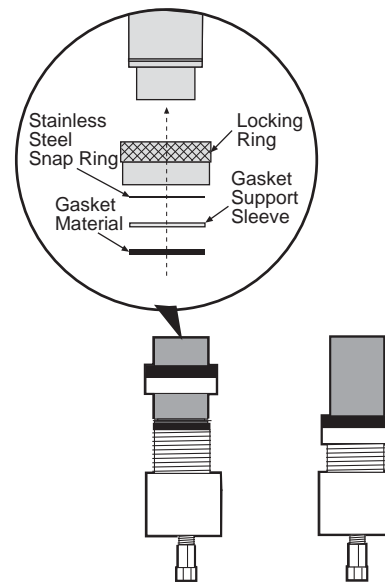

NOTE: Load side fittings are same type as source.



CAUTION: Water piping exposed to outside temperature may be subject to freezing.

General Installation Information cont.

Water Quality

It is the responsibility of the system designer and installing contractor to ensure that acceptable water quality is present and that all applicable codes have been met in these installations. Failure to adhere to the guidelines in the water quality table could result in loss of warranty. In ground water situations where scaling could be heavy or where biological growth such as iron bacteria will be present, a closed loop system is recommended. The heat exchanger coils in ground water systems may, over a period of time, lose heat exchange capabilities due to a buildup of mineral deposits inside. These can be cleaned, but only by a qualified service mechanic, as special solutions and pumping equipment are required. Hot water generator coils can likewise become scaled and possibly plugged. In areas with extremely hard water, the owner should be informed that the heat exchanger may require occasional flushing.

Units with cupronickel heat exchangers are recommended for open loop applications due to the increased resistance to build-up and corrosion, along with reduced wear caused by acid cleaning. Failure to adhere to the guidelines in the water quality table could result in the loss of warranty.

Water Treatment

Do not use untreated or improperly treated water. Equipment damage may occur. The use of improperly treated or untreated water in this equipment may result in scaling, erosion, corrosion, algae or slime. Purchase of a pre-mix antifreeze could significantly improve system reliability if the water quality is controlled and there are additives in the mixture to inhibit corrosion. There are many examples of such fluids on the market today such as Environol™ 1000

(pre-mix ethanol), and others. The services of a qualified water treatment specialist should be engaged to determine what treatment, if any, is required. The product warranty specifically excludes liability for corrosion, erosion or deterioration of equipment.

The heat exchangers and water lines in the units are copper or cupronickel tube. There may be other materials in the buildings piping system that the designer may need to take into consideration when deciding the parameters of the water quality. If antifreeze or water treatment solution is to be used, the designer should confirm it does not have a detrimental effect on the materials in the system.

Contaminated Water

In applications where the water quality cannot be held to prescribed limits, the use of a secondary or intermediate heat exchanger is recommended to separate the unit from the contaminated water. The table above outlines the water quality guidelines for unit heat exchangers. If these conditions are exceeded, a secondary heat exchanger is required. Failure to supply a secondary heat exchanger where needed will result in a warranty exclusion for primary heat exchanger corrosion or failure.

Material		Copper	90/10 Cupronickel	316 Stainless Steel
pH	Acidity/Alkalinity	7 - 9	7 - 9	7 - 9
Scaling	Calcium and Magnesium Carbonate	(Total Hardness) less than 350 ppm	(Total Hardness) less than 350 ppm	(Total Hardness) less than 350 ppm
Corrosion	Hydrogen Sulfide	Less than 0.5 ppm (rotten egg smell appears at 0.5 ppm)	10 - 50 ppm	Less than 1 ppm
	Sulfates	Less than 125 ppm	Less than 125 ppm	Less than 200 ppm
	Chlorine	Less than 0.5 ppm	Less than 0.5 ppm	Less than 0.5 ppm
	Chlorides	Less than 20 ppm	Less than 125 ppm	Less than 300 ppm
	Carbon Dioxide	Less than 50 ppm	10 - 50 ppm	10 - 50 ppm
	Ammonia	Less than 2 ppm	Less than 2 ppm	Less than 20 ppm
	Ammonia Chloride	Less than 0.5 ppm	Less than 0.5 ppm	Less than 0.5 ppm
	Ammonia Nitrate	Less than 0.5 ppm	Less than 0.5 ppm	Less than 0.5 ppm
	Ammonia Hydroxide	Less than 0.5 ppm	Less than 0.5 ppm	Less than 0.5 ppm
	Ammonia Sulfate	Less than 0.5 ppm	Less than 0.5 ppm	Less than 0.5 ppm
	Total Dissolved Solids (TDS)	Less than 1000 ppm	1000 - 1500 ppm	1000 - 1500 ppm
	LSI Index	+0.5 to -0.5	+0.5 to -0.5	+0.5 to -0.5
Iron Fouling (Biological Growth)	Iron, FE ²⁺ (Ferrous) Bacterial Iron Potential	< 0.2 ppm	< 0.2 ppm	< 0.2 ppm
	Iron Oxide	Less than 1 ppm, above this level deposition will occur	Less than 1 ppm, above this level deposition will occur	Less than 1 ppm, above this level deposition will occur
Erosion	Suspended Solids	Less than 10 ppm and filtered for max. of 600 micron size	Less than 10 ppm and filtered for max. of 600 micron size	Less than 10 ppm and filtered for max. of 600 micron size
	Threshold Velocity (Fresh Water)	< 6 ft/sec	< 6 ft/sec	< 6 ft/sec

NOTES: Grains = ppm divided by 17
mg/L is equivalent to ppm

2/22/12

General Installation Information cont.

Freeze Detection Limit (Water Flow)

Set the freeze detection limit switch SW2 #2 to “Loop” on the printed circuit board for applications using a closed loop antifreeze solution. On applications using an open loop/ground water system, set to “Well” (the factory setting). If using closed loop and no antifreeze solution leave in “Well” position (the factory setting).

Condensate Drain

The internal condensate drain assembly consists of a drain tube, which is attached to the drain pan, a 3/4 in. PVC female adapter, and a flexible connecting hose. The female adapter may exit either the front or the side of the vertical cabinet. The adapter will be glued to the field-installed PVC condensate piping. A condensate hose is inside all cabinets as a trapping loop; therefore, an external trap is not necessary.

Closed Loop Ground Source Systems

Once piping is completed between the unit, flow center and the ground loop, final purging and charging of the loop is needed. A flush cart (at least a 1.5 HP pump) is needed to achieve adequate flow velocity in the loop to purge air and dirt particles from the loop itself. Antifreeze solution is used in most areas to prevent freezing. Flush the system adequately to remove as much air as possible then pressurize the loop to a static pressure of 50-75 psi (winter) or 40-50 psi (summer). This is normally adequate for good system operation. Loop static pressure will fluctuate with the seasons. Pressures will be higher in the winter months than during the cooling season. This fluctuation is normal and should be considered when charging the system initially.

After pressurization, be sure to burp the pump. Open the screw 2 turns only in the end of the pump motor (if Grundfos® pumps are used) to allow trapped air to be discharged and to ensure the motor housing has been flooded. Ensure the loop flow center provides adequate

flow through the unit by checking pressure drop across the heat exchanger (Refer to Pressure Drop table). Usually 2.5-3 gpm of flow per ton of cooling capacity is recommended in earth loop applications. Refer to Wiring Schematics for loop pump power wiring details.

Multiple Units on One Flow Center

When two units are connected to one loop pumping system, pump control is automatically achieved by connecting the slave terminals on connector P2 in both units with 2-wire thermostat wire. These terminals are polarity dependent (see below). The loop pump(s) may be powered from either unit, whichever is more convenient. If either unit calls, the loop pump(s) will automatically start. The use of two units on one flow center is generally limited to a total of 20 gpm capacity.

It is recommended that water solenoid valves be installed on heat pumps that share a flow center. This is to allow water flow through only the heat pump that has a demand. Circulating fluid through a heat exchanger of a system that is not operating could be detrimental to the long term reliability of the compressor

Closed Loop: Ground Source Application

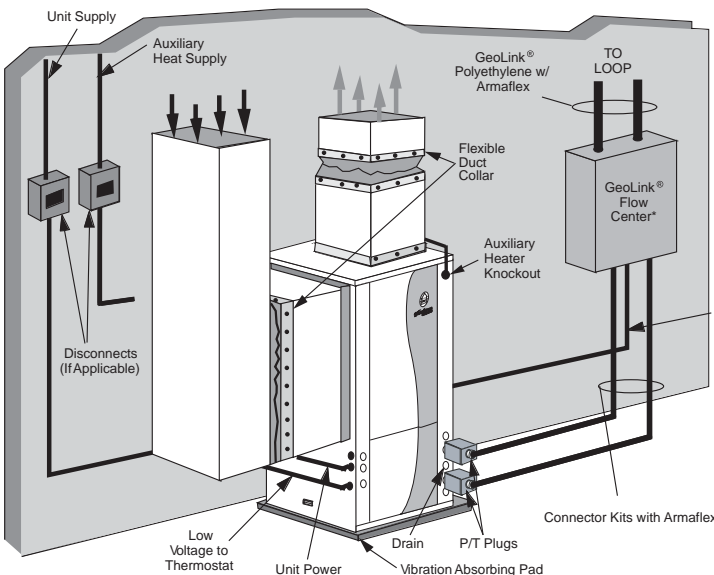

* For complete information, refer to GeoLink® Flow Center Installation Manual

Primary/Secondary Hook-up

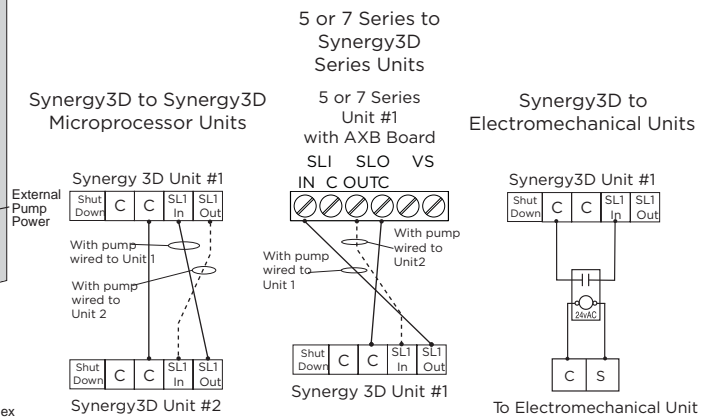

Open Loop Ground Water Systems

Typical open loop piping is shown in the Open System: Ground Water Application. Always maintain water pressure in the heat exchanger by placing water control valves at the outlet of the unit to prevent mineral precipitation. Use a closed, bladder-type expansion tank to minimize mineral formation due to air exposure. Ensure proper water flow through the unit by checking pressure drop across the heat exchanger and comparing it to the figures in the pressure drop tables. Normally about 2 GPM flow rate per ton of cooling capacity (1.5 GPM per ton minimum at 50° F) is needed in open loop systems.

Open Loop Solenoid Valve Connection Option

Typical slow operating external 24V water solenoid valve (type V) wiring.

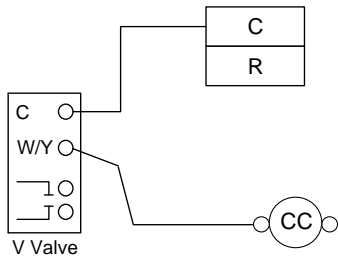

Discharge water from the unit is not contaminated in any manner and can be disposed of in various ways such as recharge well, storm sewer, drain field, adjacent stream or pond, etc. depending on local building codes. Most local codes forbid the use of sanitary sewer for disposal. Consult your local building and zoning department to ensure compliance in your area.

Open Loop Solenoid Valve Connection Option

Typical quick operating external 24V water solenoid valve (type PPV100 or BPV100) wiring.

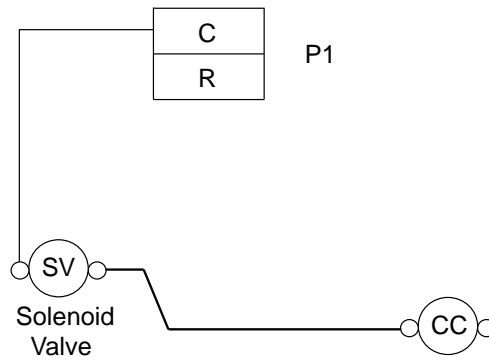

Open System: Ground Water Application

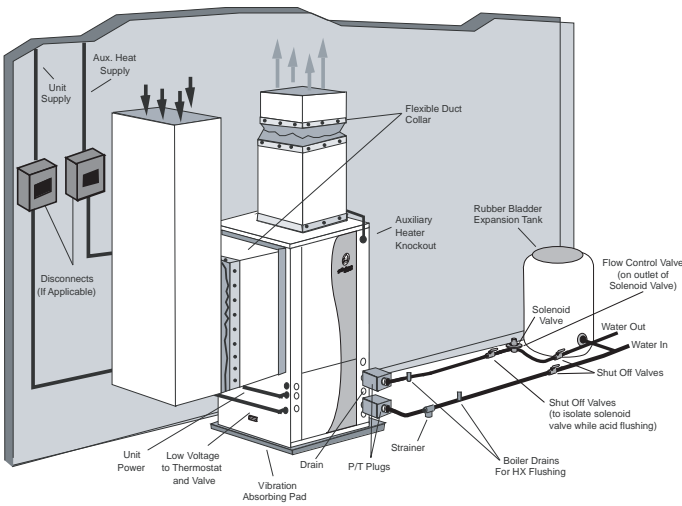

Open Loop Solenoid Valve Connection Option: Wiring diagram for dual water valve installations, one type V slow operating solenoid and one BPV100/PPV100 quick operating solenoid.

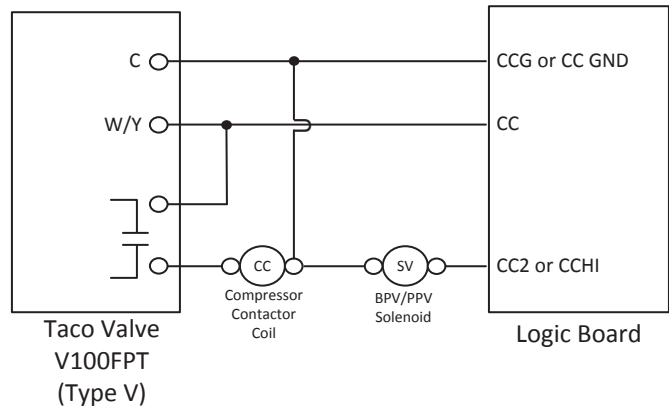

NOTES: For open loop ground water systems or systems that do not contain and antifreeze solution, set SW2-#2 to the "Well" position.

Hot Water Generator Connections

To maximize the benefits of the hot water generator a minimum 50-gallon water heater is recommended. For higher demand applications, use an 80-gallon water heater as shown below or two 50-gallon water heaters connected in a series. Electric water heaters are recommended. Make sure all local electrical and plumbing codes are met for installing a hot water generator. The Synergy3D is not supplied with an internal circulator. A DPK5 kit will need to be purchased to connect to the hot water generator.

The DPK5 kit is supplied with installation instructions, circulator, tank adaptor and temperature limit switch. Be sure to burp the pump. Open the screw 2 turns only in the end of the pump motor (if Grundfos® pumps are used) to allow trapped air to be discharged and to ensure the motor housing has been flooded. A water softener is recommended with hard water (greater than 10 grains or 170 ppm total hardness).

Typical Buffer Tank Installation

Synergy3D with Hydronic Storage Tank and Domestic Water Heater Tank

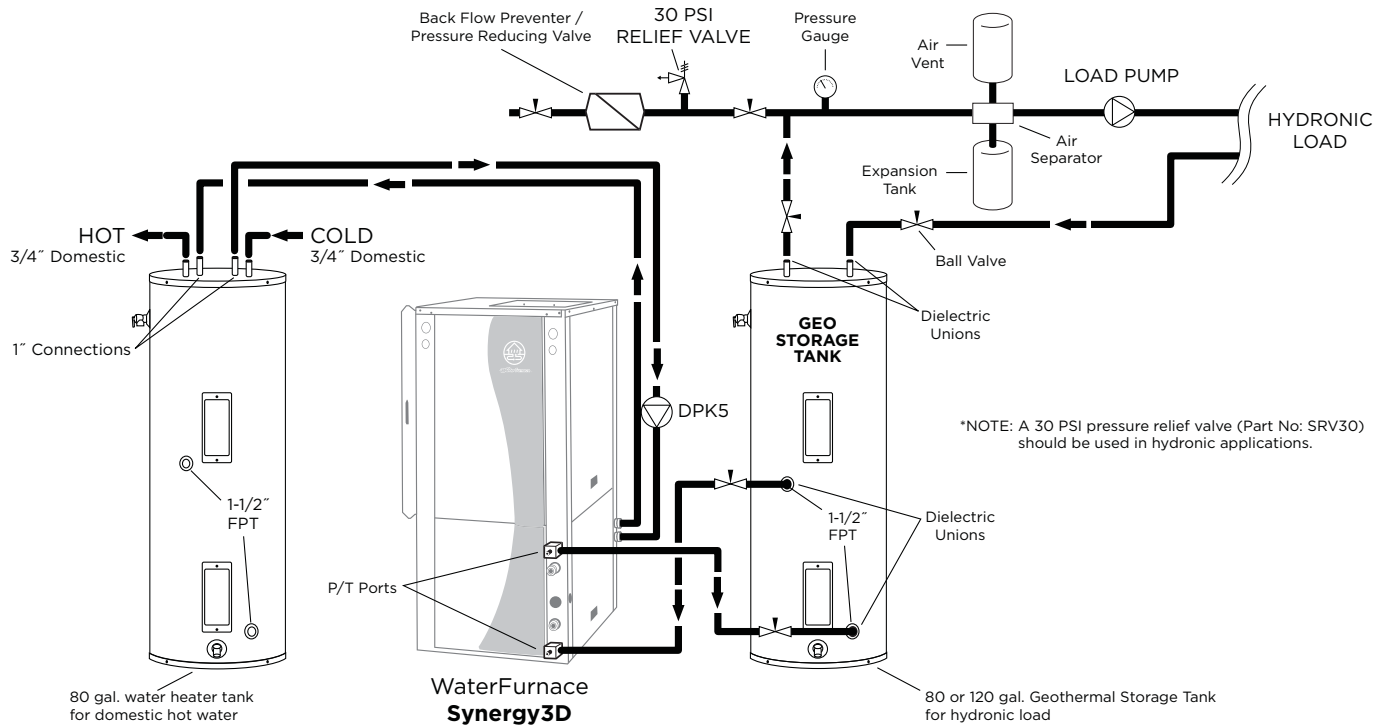

Synergy3D Hydronic Storage Tank Recommendations

Unit Model	Copper I.D. Pipe Size (in)	Flow Rates (GPM)	Maximum Feet of Pipe One Way	Total Number of Elbows	Recommended Storage Tank Size
SDV038	1.25	9	30'	10	80 U.S. Gals
SDV049	1.25	12	30'	10	80 U.S. Gals
SDV064	1.25	15	30'	10	120 U.S. Gals
SDV072	1.50	18	30'	10	120 U.S. Gals

Hydronic Section

General guidelines are shown below for component selection and design/installation criteria for the piping system. Local codes supersede any recommendations in this manual.

Shut off/flow regulation valves: Use full port ball valves or gate valves for component isolation. If valves are going to be used frequently, ball valves are recommended. Globe valves are designed for flow regulation. Always install globe valves in the correct direction (fluid should enter through the lower body chamber).

Check valves: Swing check valves must be installed in the horizontal position with the bonnet of the valve upright. Spring check valves can be mounted in any position. A flow check valve is required to prevent thermo-siphoning (or gravity flow) when the circulator pump is off or when there are two circulators on the same system.

Storage (Buffer) tank: A buffer tank is required for all hydronic heating systems using Synergy3D heat pumps. The tank should be sized to provide 2 gallons of storage capacity for every one thousand btuh's of nominal heat pump capacity.

Pressure relief valve: Most codes require the use of a pressure relief valve if a closed loop heat source can be isolated by valves. Even if local code does not require this device, WaterFurnace recommends its installation. If the pressure relief valve in the buffer tank is not already rated at 30 psi (207 kPa) maximum pressure, one must be installed. The pressure relief valve should be tested at start up for operation. This valve can also be used during initial filling of the system to purge air. Note that the waste pipe must be at least the same diameter as the valve outlet (never reduce), and valves may not be added to this pipe. The bottom of the pipe must terminate at least 6" (15 cm) above the floor. If the piping is connected to a drain, there must be an air gap.

Backflow prevention check valves: Most codes require backflow prevention check valves. Note that a single check valve is not equal to a backflow prevention check valve. Even if local code does not require this device, WaterFurnace recommends its installation. This is particularly important if the system will use antifreeze.

Pressure reducing valves or feed water valves: This valve lowers the pressure from the make-up water line to the system. Most are adjustable and directional. A "fast fill" valve is required for initial filling of the system. Some have screens, which must be cleaned after the initial filling. If there is a restriction in the screen, the system could go to 0 psi (0 kPa), potentially causing pumps(s) failure. A valve should be installed on each side of the pressure reducing

valve for servicing. Both valves should have tags reading "Do not shut this valve under normal operation – service valve only".

Expansion tanks: Expansion tanks are required on hydronic systems to help absorb the pressure swings as the temperature in the system fluctuates.

Elbows/tees: Long radius elbows or two 45° elbows will lower pressure drop. Standard tees have a greater restriction on the "T" portion than tees designed with angled outlet ports.

Antifreeze: Antifreeze is required if any of the piping system is located in areas subject to freezing.

Dielectric unions: Dielectric unions are recommended whenever connecting two dissimilar metals to one and other to prevent electro-galvanic corrosion.

When using the various types of hydronic heat distribution systems, the temperature limits of the geothermal system must be a major consideration. In new construction, the distribution system can easily be designed with the temperature limits in mind. In retrofits, care must be taken to address the operating temperature limits of the existing distribution system. The maximum storage tank temperature for the Synergy3D is 130°F (54.4°C). Typical in floor radiant systems require much lower temperatures, typically 100°-115°F, which is ideal for the Synergy3D.

The Synergy3D uses an external temperature sensor such as the lower thermostat in a water heater storage tank to control the tank temperature. The thermostat should be wired to the Synergy3D P5 connector wires, P5-11 and P5-4 tan wires. When the tank temperature drops below the thermostat setting the contacts in the thermostat will close and initiate a signal to the Synergy3D to heat water. A storage tank must be used to store the heated water supplied by the Synergy3D. It is not recommended to send heated water from the Synergy3D directly to the hydronic zones since the Synergy3D also has the ability to condition the space with forced air. There must be adequate storage capacity in the storage tank to accommodate the hydronic load while the Synergy3D is operating in forced air mode. The hydronic storage tank should be sized to provide 2 gallons of storage capacity for every one thousand Btu's of nominal heat pump capacity.

Adequate rate of flow (GPM) is very important to system performance and long term reliability. Follow the guidelines for recommended flow and pipe sizing in the Synergy3D Recommendations table.

Hydronic Section cont.

The unit uses an external temperature sensor such as the lower thermostat in a water heater storage tank to control the tank temperature. The thermostat should be wired to the unit P5 connector wires, P5-11 and P5-4 tan wires. When the tank temperature drops below the thermostat setting the contacts in the thermostat will close and initiate a signal to the unit to heat water.

A storage tank must be used to store the heated water supplied by the unit. It is not recommended to send heated water from the unit directly to the hydronic zones since the unit also has the ability to condition the space with forced air. There must be adequate storage capacity in the storage tank to accommodate the hydronic load while the unit is operating in forced air mode. The hydronic storage tank should be sized to provide 2 gallons of storage capacity for every one thousand Btuh's of nominal heat pump capacity.

Adequate rate of flow (GPM) is very important to system performance and long term reliability. Follow the guidelines for recommended flow and pipe sizing in the unit recommendations table.

Be sure to burp the pump. Open the screw 2 turns only in the end of the pump motor (if Grundfos® pumps are used) to allow trapped air to be discharged and to ensure the motor housing has been flooded.

The red "courtesy" wires exit out of the top of the Geo Storage tank. The wires must be connected to the tank thermostat and to P5 tan connector wires, P5-11 and P5-4 on the main logic board.

WaterFurnace Geothermal Storage Tank Thermostat



Synergy3D must be wired to the thermostat screw terminals. The yellow thermistor wires will not operate with the Synergy3D as they are used with the NSW Series water-to-water.

Electrical Connections

General

Be sure the available power is the same voltage and phase as that shown on the unit serial plate. Line and low voltage wiring must be done in accordance with local codes or the National Electric Code, whichever is applicable.

Unit Power Connection

Line Voltage connection is made by connecting the incoming line voltage wires to the “L” side of the contactor as shown. Consult the Electrical Data table for correct fuse size.

External Loop Pump Power Connection

If the unit is to be used with an external loop pump (FC1 or FC2 flow center), the pump(s) will be connected to the terminals on PB1 in the unit electrical box as shown. The pumps will automatically be cycled as required by the unit or by a secondary signal from another Synergy3D unit sharing the flow center. (Refer to the Wiring Schematics section.)

208 Volt Operation

All 208-230 volt units are factory wired for 230 volt operation. For 208 volt operation, the red and the blue transformer wires must be switched on terminal strip PS1. (Refer to the Wiring Schematics section.)

Synergy3D Line Voltage 208-230/60/1

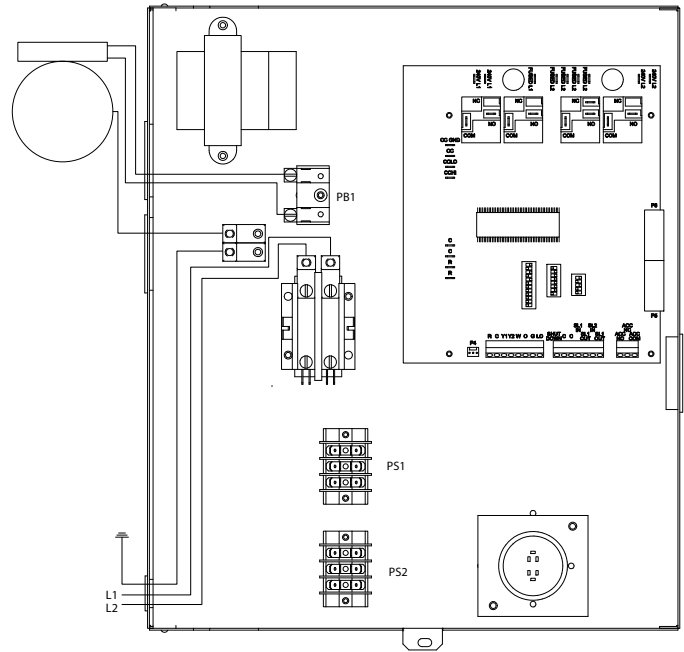

Electronic Thermostat Installation

Installation

Position the thermostat subbase against the wall so that it is level and the thermostat wires protrude through the subbase. Mark the position of the subbase mounting holes and drill holes with a 3/16 in. bit. Install anchors and secure base to the wall. Thermostat wire must be 8 conductor 18 AWG wire. Strip the wires back 1/4 in. (longer strip lengths may cause shorts) and insert the thermostat wires into the Synergy3D connector as shown in the Thermostat Wiring diagram. Tighten the screws to ensure good connections. The thermostat has the same type of connectors, requiring the same wiring. See instructions enclosed in the thermostat for detailed installation and operation information.

Thermostat Wiring

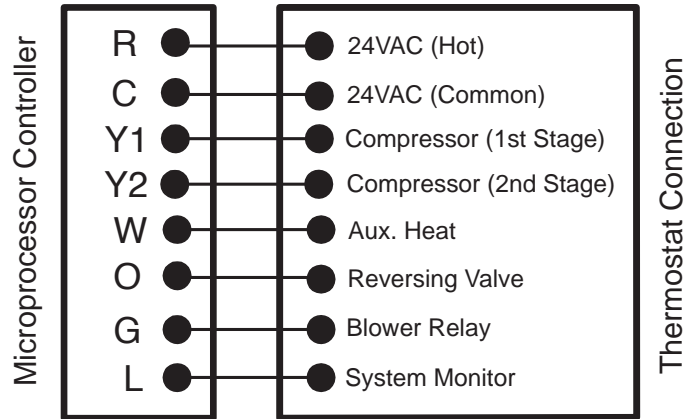

Other Thermostats

The Synergy3D unit is compatible with virtually any 24VAC thermostat. However, the multi-stage nature of this product requires a 3-stage heating/2-stage cooling type thermostat.



NOTE: DIP switch SW2-8 is required to be in the "OFF" position for the control to operate with FaultFlash or ComforTalk thermostats. SW2-8 in the "ON" position configures the control to operate with typical thermostats (continuous lockout signal). There must be a wire connecting Y2 on the microprocessor controller to 2nd stage compressor on the thermostat for proper operation.

Auxiliary Heat

Auxiliary Heat Electrical Data

Model	Supply Circuit	Heater Amps		Min Circuit Amp		Max Fuse (USA)		Max Fuse (CAN)		Max CKT BRK	
		208V	240V	208V	240V	208V	240V	208V	240V	208V	240V
EAL(H)10A	Single	34.7	40	53.3	60	60	60	60	60	60	60
EAL(H)15A	Single	52.0	60	75	85	80	90	80	90	70	100
	L1/L2	34.7	40	53.3	60	60	60	60	60	60	60
	L3/L4	17.3	20	21.7	25	25	25	25	25	20	30
EAL(H)20A	Single	69.3	80	96.7	110	100	110	100	110	100	100
	L1/L2	34.7	40	53.3	60	60	60	60	60	60	60
	L3/L4	34.7	40	43.3	50	45	50	45	50	40	50

All heaters rated single phase 60 cycle and include unit fan load

All fuses type "D" time delay (or HACR circuit breaker in USA)

Vertical rear discharge models use the horizontal (EALH) auxiliary heat kit

Auxiliary Heat Ratings

Model	KW		Stages	BTU/HR		Min CFM	Compatibility			
	208V	230V		208V	230V		038	049	064	072
EAL10A	7.2	9.6	2	24,600	32,700	1100	•	•	•	•
EAL15A	10.8	14.4	3	36,900	49,100	1250	•	•	•	•
EAL20A	14.4	19.2	4	49,200	65,500	1500		•	•	•

NOTES: The heat pump requires Medium and High blower setting to be above the minimum CFM for the heater selected.
Rear discharge uses the horizontal auxiliary heat kits, EALH10A, 15A, or 20A.

5/6/09

Electrical Data

Model	Rated Voltage	Voltage Min/Max	Compressor				Int Pump FLA	Ext Loop FLA	Blower Motor FLA	Total Unit FLA	Min Circ Amp	Max Fuse/HACR
			MCC	RLA	LRA	LRA**						
038	208-230/60/1	187/253	23.8	15.2	83.0	30.0	1.07	5.4	4.0	25.7	29.5	40
038*	208-230/60/1	187/253	23.8	15.2	83.0	30.0	1.07	5.4	7.0	28.7	32.5	45
049	208-230/60/1	187/253	33.0	21.1	104.0	37.0	1.07	5.4	4.0	31.6	36.8	50
049*	208-230/60/1	187/253	33.0	21.1	104.0	37.0	1.07	5.4	7.0	34.6	39.9	60
064	208-230/60/1	187/253	42.3	27.1	152.9	54.0	1.07	5.4	7.0	40.5	47.3	70
072	208-230/60/1	187/253	46.3	29.6	179.2	63.0	1.07	5.4	7.0	43.1	50.5	80

Rated Voltage of 208-230/60/1.
 HACR circuit breaker in USA only.
 Local electrical codes overrule any wiring recommendations.
 * With optional 1 HP ECM motor
 **With optional IntelliStart

Min/Max Voltage of 187/253.
 All fuses Class RK-5.

09/24/13

Blower Performance Data

Model	Max ESP	Air Flow Dip Switch Settings											
		1	2	3	4	5	6	7	8	9	10	11	12
038	0.50	650	750 L	850	1000	1100 M	1200	1300 H	1400	1500			
038 w/1hp*	0.75	800 L	1000	1100 M	1300 H	1500	1600	1800					
049	0.50	650	800 L	900	1050	1150	1250	1350 M	1450	1550 H			
049 w/1hp*	0.75	800 L	900	1000	1200	1400 M	1600 H	1700	1850	2000	2200	2300	2400
064	0.75	800	950 L	1100	1300	1500 M	1750	1950 H	2100	2300			
072	0.75	800	950	1100 L	1300	1500	1750	1950 M	2100 H	2300			

Factory settings are at recommended L-M-H DIP switch locations
 M-H settings MUST be located within boldface CFM range
 Lowest and Highest DIP switch settings are assumed to be L and H respectively

CFM is controlled within 35% up to the maximum ESP
 Max ESP includes allowance for wet coil and standard filter

A 12-position DIP switch package on the heat pump control allows the airflow levels to be set for Low, Medium and High speed when using the variable speed ECM blower motor.

Only three of the DIP switches can be in the “On” position. The first “On” switch (the lowest position number) determines the “Low Speed Blower” setting. The second “On” switch determines the “Medium Speed Blower” setting, and the third “On” switch determines the “High Speed Blower” setting.

The example to the right shows SW1 on the heat pump control board configured for the following 049 airflow settings:

- Low Speed Blower: 800 CFM
- Medium Speed Blower: 1350 CFM
- High Speed Blower: 1550 CFM

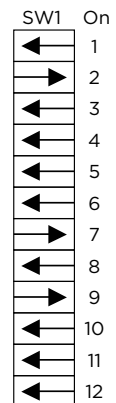

Dimensional Data

Topflow Discharge

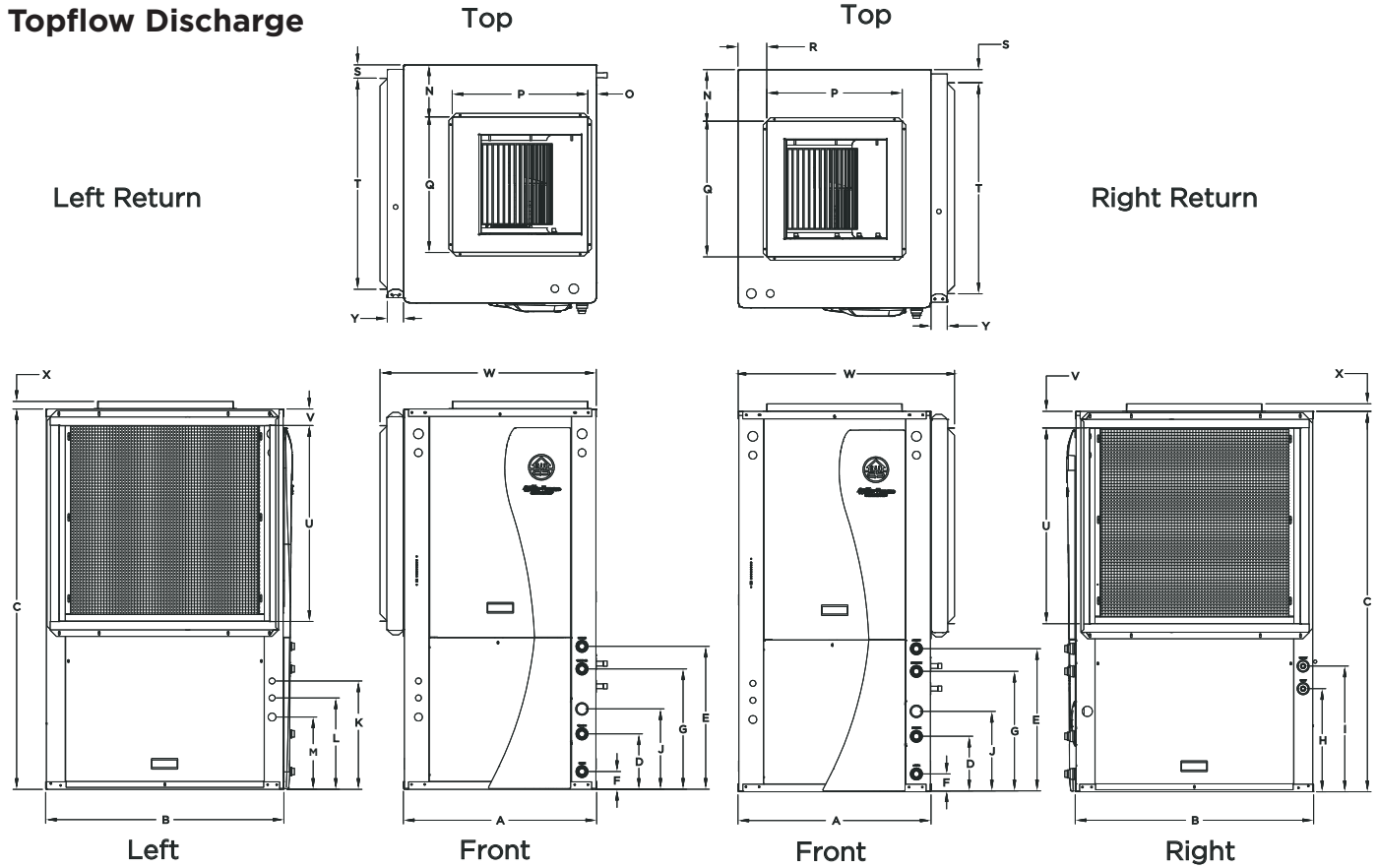

Vertical Topflow Model	Overall Cabinet			Water Connections											Electrical Connections		
	A	B	C	D	E	F	G	H	I	J	Loop Water FPT	Hydronic Water FPT	HWG Sweat (I.D.)	K	L	M	
	Width	Depth	Height	Loop In	Hydronic Out	Hydronic In	Loop Out	HWG In	HWG Out	Condensate				1/2" cond Low Voltage	1/2" cond Ext Pump	3/4" cond Power Supply	
038	in. 25.6 cm. 65.0	31.6 80.3	50.4 128.0	7.3 18.5	18.9 48.0	2.3 5.8	15.9 40.4	13.6 34.5	16.6 42.2	10.6 26.9	1" Swivel	1" Swivel	1/2" Female	14.4 36.6	12.1 30.7	9.6 24.4	
049	in. 25.6 cm. 65.0	31.6 80.3	54.4 138.2	7.3 18.5	18.9 48.0	2.3 5.8	15.9 40.4	15.9 40.4	18.9 48.0	10.6 26.9	1" Swivel	1" Swivel	1/2" Female	14.4 36.6	12.1 30.7	9.6 24.4	
064	in. 25.6 cm. 65.0	31.6 80.3	58.4 148.3	7.3 18.5	18.9 48.0	2.3 5.8	15.9 40.4	15.9 40.4	18.9 48.0	10.6 26.9	1" Swivel	1" Swivel	1/2" Female	14.4 36.6	12.1 30.7	9.6 24.4	
072	in. 25.6 cm. 65.0	31.6 80.3	58.4 148.3	7.3 18.5	18.9 48.0	2.3 5.8	15.9 40.4	15.9 40.4	18.9 48.0	10.6 26.9	1" Swivel	1" Swivel	1/2" Female	14.4 36.6	12.1 30.7	9.6 24.4	

Discharge Connection duct flange installed (±0.10 in)				Return Connection using standard deluxe filter rack (±0.10 in)						Misc	
N	O	P Supply Width	Q Supply Depth	R	S	T Return Depth	U Return Height	V	W	X	Y
6.9	1.1	18.0	18.0	3.8	1.7	28.1	26.0	2.2	28.7	1.0	2.1
17.5	2.8	45.7	45.7	9.7	4.3	71.4	66.0	5.6	72.9	2.5	5.3
6.9	1.1	18.0	18.0	3.8	1.7	28.1	30.0	2.2	28.7	1.0	2.1
17.5	2.8	45.7	45.7	9.7	4.3	71.4	76.2	5.6	72.9	2.5	5.3
6.9	1.1	18.0	18.0	3.8	1.7	28.1	34.0	2.2	28.7	1.0	2.1
17.5	2.8	45.7	45.7	9.7	4.3	71.4	86.4	5.6	72.9	2.5	5.3
6.9	1.1	18.0	18.0	3.8	1.7	28.1	34.0	2.2	28.7	1.0	2.1
17.5	2.8	45.7	45.7	9.7	4.3	71.4	86.4	5.6	72.9	2.5	5.3

10/16/13

Condensate is 3/4 in. PVC female glue socket and is switchable from side to front
 Unit shipped with deluxe 2 in. (field adjustable to 1 in.) duct collar/filter rack extending from unit 3.25 in. and is suitable for duct connection.
 Discharge flange is field installed and extends 1 in. [25.4 mm] from cabinet
 Decorative molding and water connections extend 1.2 in. [30.5 mm] beyond front of cabinet.

Dimensional Data cont.

Rear Discharge

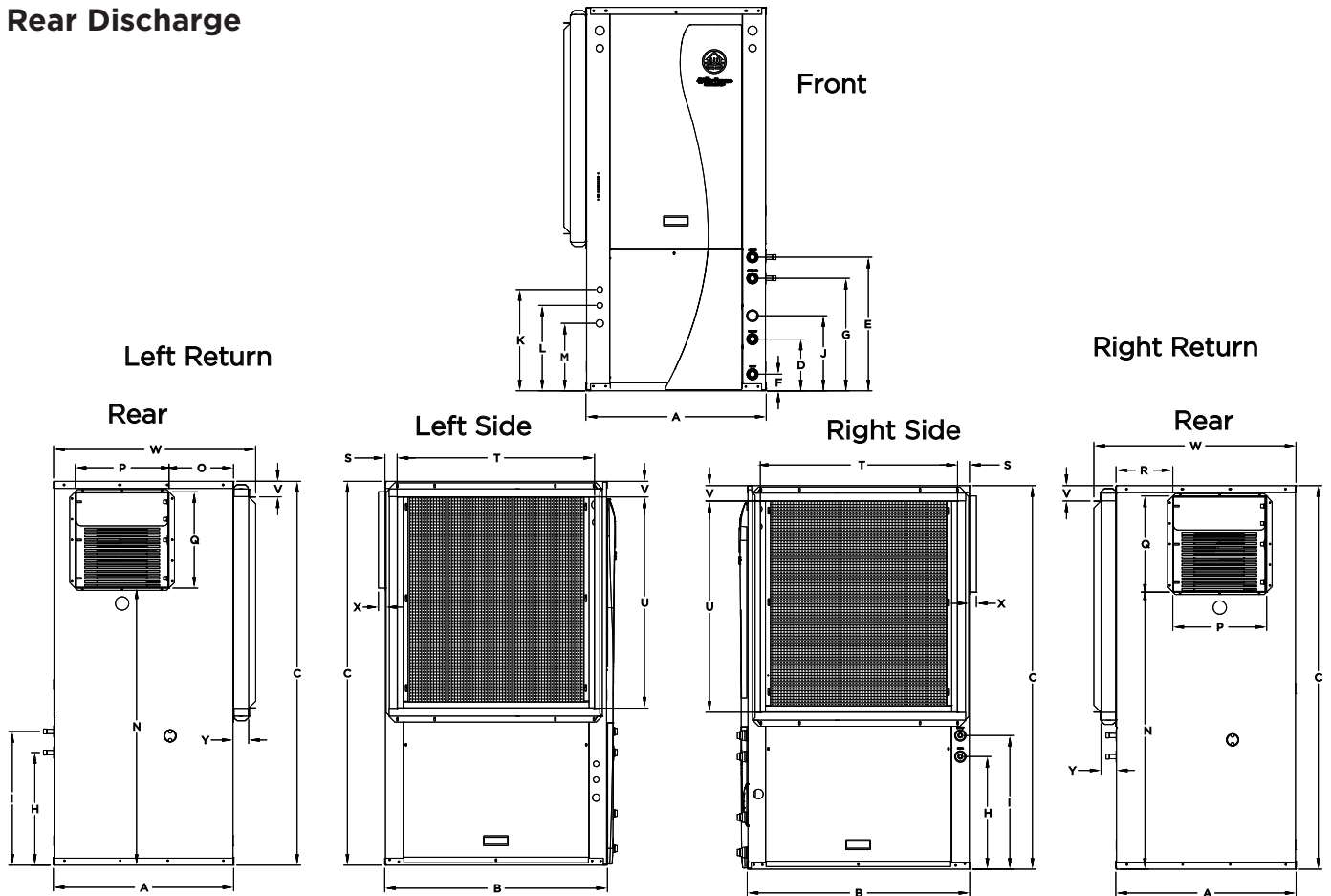

Vertical Backflow Model	Overall Cabinet			Water Connections											Electrical Connections		
	A Width	B Depth	C Height	D Loop In	E Hydronic Out	F Hydronic In	G Loop Out	H HWG In	I HWG Out	J Condensate	Loop Water FPT	Hydronic Water FPT	HWG Sweat (I.D.)	K 1/2" cond Low Voltage	L 1/2" cond Ext Pump	M 3/4" cond Power Supply	
049	in. 25.6 cm. 65.0	31.6 80.3	54.4 138.2	7.3 18.5	18.9 48.0	2.3 5.8	15.9 40.4	15.9 40.4	18.9 48.0	10.6 26.9	1" Swivel	1" Swivel	1/2" Female	14.4 36.6	12.1 30.7	9.6 24.4	
064	in. 25.6 cm. 65.0	31.6 80.3	58.4 148.3	7.3 18.5	18.9 48.0	2.3 5.8	15.9 40.4	15.9 40.4	18.9 48.0	10.6 26.9	1" Swivel	1" Swivel	1/2" Female	14.4 36.6	12.1 30.7	9.6 24.4	
072	in. 25.6 cm. 65.0	31.6 80.3	58.4 148.3	7.3 18.5	18.9 48.0	2.3 5.8	15.9 40.4	15.9 40.4	18.9 48.0	10.6 26.9	1" Swivel	1" Swivel	1/2" Female	14.4 36.6	12.1 30.7	9.6 24.4	

Discharge Connection duct flange installed (±0.10 in)				Return Connection using std deluxe filter rack (±0.10 in)						Misc	
N	O	P Supply Width	Q Supply Depth	R	S	T Return Depth	U Return Height	V	W	X	Y
39.4	9.1	13.3	13.6	8.1	1.7	28.1	30.0	2.2	28.7	1.0	2.1
100.1	23.1	33.8	34.5	20.6	4.3	71.4	76.2	5.6	72.9	2.5	5.3
43.4	9.1	13.3	13.6	8.1	1.7	28.1	34.0	2.2	28.7	1.0	2.1
110.2	23.1	33.8	34.5	20.6	4.3	71.4	86.4	5.6	72.9	2.5	5.3
43.4	9.1	13.3	13.6	8.1	1.7	28.1	34.0	2.2	28.7	1.0	2.1
110.2	23.1	33.8	34.5	20.6	4.3	71.4	86.4	5.6	72.9	2.5	5.3

Condensate is 3/4 in. PVC female glue socket and is switchable from side to front
 Unit shipped with deluxe 2 in. (field adjustable to 1 in.) duct collar/filter rack extending from unit 3.25 in. and is suitable for duct connection.
 Discharge flange is field installed and extends 1 in. [25.4 mm] from cabinet
 Decorative molding and water connections extend 1.2 in. [30.5 mm] beyond front of cabinet.

10/16/2013

Physical Data

Model	038	049	064	072
Compressor (1 each)	Copeland Scroll			
Factory Charge R410a, oz [kg]	82 [2.32]	102 [2.89]	120 [3.40]	120 [3.40]
ECM Fan Motor & Blower				
Fan Motor Type/Speeds	Variable Speed ECM			
Fan Motor- hp [W]	1/2 [373]	1/2 [373]	1 [746]	1 [746]
Blower Wheel Size (Dia x W), in. [mm]	11 x 10 [279 x 254]	11 x 10 [279 x 254]	11 x 10 [279 x 254]	11 x 10 [279 x 254]
Coax and Water Piping				
Loop Water Connections Size - Swivel - in [mm]	1" [25.4]	1" [25.4]	1" [25.4]	1" [25.4]
Hydronic Water Connections Size - Swivel - in [mm]	1" [25.4]	1" [25.4]	1" [25.4]	1" [25.4]
HWG Connection Size - Female Sweat (I.D.) - in [mm]	1/2" [12.7]	1/2" [12.7]	1/2" [12.7]	1/2" [12.7]
Coax & Piping Water Volume - gal [l]	1.3 [4.9]	1.6 [6.1]	1.6 [6.1]	1.6 [6.1]
Vertical				
Air Coil Dimensions (H x W), in. [mm]	28 x 25 [711 x 635]	32 x 25 [813 x 635]	36 x 25 [914 x 635]	36 x 25 [914 x 635]
Air Coil Total Face Area, ft ² [m ²]	4.9 [0.451]	5.6 [0.570]	6.3 [0.641]	6.3 [0.641]
Air Coil Tube Size, in [mm]	3/8 [9.5]	3/8 [9.5]	3/8 [9.5]	3/8 [9.5]
Air Coil Number of rows	3	3	4	4
Filter Standard - 2" [51mm] Pleated MERV11 Disposable, in [mm]	28 x 30 [712 x 762]	32 x 30 [813 x 762]	36 x 30 [914 x 762]	36 x 30 [914 x 762]
Weight - Operating, lb [kg]	425	530	540	540
Weight - Packaged, lb [kg]	445	550	560	560

3/15/17

Microprocessor Control

Startup

The unit will not operate until all the inputs and safety controls are checked for normal conditions. At first power-up, a four minute delay is employed before the compressor is energized.

Component Sequencing Delays

Components are sequenced and delayed for optimum space conditioning performance.

Accessory Relay

The accessory relay will be used to control a refrigerant solenoid valve. The accessory relay will turn on when the control is operating in forced air heating, forced air cooling and when there is no active thermostat input. The relay will be off when operating in hot water mode.

Loop Pump Linking Signals

A signal between multiple Synergy3D control boards at the inputs and outputs (SL1-In and Out) will provide for remote control of the loop pump on any unit.

Condensate Overflow Protection

The control board incorporates an impedance sensing liquid sensor at the top of the drain pan. Upon a continuous 30-second sensing of the condensate, compressor operation is suspended (see Fault Retry), and the condensate overflow lockout LED begins flashing.

Shutdown Mode

A 24VAC **Common** signal to the “shutdown” input on the control board puts the unit into shutdown mode. Compressor, hot water pump, and blower operation are suspended.

Short Cycle Protection

The control employs a minimum “off” time of four minutes and a minimum “on” time of two minutes for short cycle protection of the compressor.

Safety Controls

The control receives separate signals for a high pressure switch for safety, a low pressure switch to prevent loss of charge damage, and a low suction temperature thermistor for freeze detection limit. Upon a continuous 30-second measurement of the fault (immediate for high pressure), compressor operation is suspended, the appropriate lockout LED begins flashing. (Refer to the “Fault Retry” section.)

Testing

The control allows service personnel to shorten most timing delays for faster diagnostics (Refer to Dip Switch description).

Fault Retry

All faults (except for low RPM faults with the ECM blower motor) are retried twice before finally locking the unit out. An output signal is made available for a fault LED at the thermostat. The “fault retry” feature is designed to prevent nuisance service calls.

Diagnostics

The control board allows all inputs and outputs to be displayed on the LEDs for fast and simple control board diagnosis. (Refer to Dip Switch description).

Resistance Heat Control (208-230 Units)

The electric heat control module contains the appropriate high-voltage control relays. Control signals energize the relays in the proper sequence, and the LED display board indicates which stages are energized.

IntelliStart

Some models shall be equipped with an optional IntelliStart. IntelliStart is a single-phase soft starter which reduces the normal start current (LRA) by 60%. This allows the heat pump to more easily go “off-grid.” Using IntelliStart will also provide a substantial reduction in light flicker, reduce startup noise, and improve the compressor’s start behavior. The IntelliStart is self-calibrating and may take several starts to optimize the compressor start behavior.

Features:

- Automatic adjustment of the compressor starting current to the available supply voltage —maintaining constant starting torque and current.
- Supply line impedance monitoring and compensation.
- Automatic compensation for residual backpressure in the system.
- Monitoring of supply voltage while compressor is running to prevent motor stalling, causing excessive currents, under low voltage conditions.
- Light flicker reductions of up to 10:1 over LRA under the same conditions.

ECM Airflow Selection DIP Switches (SW1)

A 12-position DIP switch package on the Synergy3D control allows the airflow levels to be set for low, medium and high speed when using the variable speed ECM blower motor (see Synergy3D Blower Performance table).

Microprocessor Control cont.

Heating Operation

Heat, 1st Stage (Y1)

The blower motor is started on low speed immediately, the loop pump is energized 5 seconds after the "Y1" input is received, and the compressor is energized on low capacity 10 seconds after the "Y1" input. The ECM blower is switched to medium speed 15 seconds after "Y1" input.

Heat, 2nd Stage (Y1,Y2) Dual Capacity Units

The second stage compressor will be activated 5 seconds after receiving a "Y2" input as long as the minimum first stage compressor run time of 1 minute has expired. The ECM blower changes from medium to high speed 15 seconds after the "Y2" input.

Heat, 3rd Stage (Y1,Y2,W) Dual Capacity Units

The 1st stage of resistance heat is energized 10 seconds after "W" input, and with continuous 3rd stage demand, the second stage of resistance heat will engage after 5 minutes.

Emergency Heat (W Only)

Low speed blower and damper output CR3 will be energized immediately after receiving (W only). The first stage auxiliary heater will be energized 10 seconds upon receiving a (W only) and the blower will shift to high speed 15 seconds after receiving a "W" only input. If the "W" input is not removed, the second, auxiliary heat output will stage on, after two minutes.

Cooling Operation

Cool, 1st Stage (Y1,O)

The blower is started immediately, and the loop pump(s) is energized 5 seconds after the "Y1" input is received. The compressor will be energized on low capacity 10 seconds after the "Y1" input. The ECM blower will shift from low to medium speed 15 seconds after the "Y1" input.

Cool, 2nd Stage (Y1, Y2, O) Dual Capacity Units

The second stage compressor will be activated 5 seconds after receiving a "Y2" input as long as the minimum first stage compressor run time of 1 minute has expired. The ECM blower changes to high speed 15 seconds after the "Y2" input.

Hydronic Cooling Slave Signal (24 vac input on P6-pin 15 violet wire)

The Synergy3D control board must be operating in cooling mode (Y1 and O inputs) or the cooling slave signal is ignored. When "Y1", and "O" inputs have been received and a cooling slave input from heating/cooling thermostat located in a hydronic heated/force air cooled zone are received the control will activate CR3 relay to open damper(s) which will allow for cooling to occur in zone. When cooling slave input (24VAC) signal is removed the control will turn off the CR3 relay output, if spring damper operation is selected, or activate, the CR4 output if POPC damper operation is selected. This will close field installed

damper(s) located in ductwork. NOTE: The control will not operate in forced air cooling and hydronic water heating modes simultaneously.

Hot Water Operation

After a hot water input is received, the diverting valve, loop pump and load water pump are turned on. Five seconds after hot water input is received the compressor is activated in second stage. Hydronic Mode Operation with Hydronic Priority Setting: If the control receives a demand to heat the space (Y1) from the thermostat during water heating mode operation, the control will engage medium ECM fan speed and the first stage auxiliary heat output. The second stage will be energized at five (5) minutes, following the first stage. The installer should set medium ECM fan speed for no less than the minimum required cfm for the installed electric heat package (see Auxiliary Heat Ratings table).

Blower (G Only)

The blower starts on low speed. Regardless of blower input (G) from thermostat, the blower will remain on low speed for 30 seconds at the end of each heating, cooling or emergency heat cycle.

Lockout Conditions

During lockout mode the appropriate unit and thermostat lockout LEDs will illuminate. The compressor, loop pump, load water pump and accessory outputs are de-energized. Unless the lockout is caused by an ECM low RPM fault, the blower will continue to run on low speed, and if the thermostat calls for heating 3rd stage, emergency heat operation will occur.

Lockout modes can be reset at the thermostat after a five-second waiting period, which restores normal operation but keeps the unit lockout LED illuminated. Interruption of power to the unit will reset a lockout without a waiting period and clear all lockout LEDs.

High Pressure

This lockout mode occurs when the normally closed safety switch is opened momentarily. >600 PSI

Low Pressure

This lockout mode occurs when the normally closed switch is opened for 30 continuous seconds. <40 PSI

Freeze Detection Limit (Water Flow)

This lockout mode occurs when the low source water thermistor temperature is at or below the selected point (well 30°F or loop 15°F) for 30 continuous seconds.

ECM Blower RPM

The control board monitors blower RPM to sense if the blower is not operating. This lockout mode occurs if the blower RPM falls below the low RPM limit (100 RPM) for 30 continuous seconds.

Microprocessor Control cont.

Hydronic Operation

SW4 (Status Board Switch)

In the OFF position, the hydronic mode is disabled and the damper connected to CR3/CR4 is opened. The switch must be in the ON position to enable the hydronic mode. **NOTE:** If the status board is not connected to the main control board, the hydronic mode is disabled.

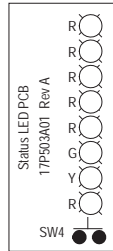

SW3 (4 and 5 Override Selection DIP Switches)

These DIP switches configure the time that the unit will run in the current mode of operation if it is not the priority mode (SW2 #3 FAH/Hydronics) of operation selected. Example: If the unit is operating in hydronic mode, forced air heat (SW2 #3 is OFF) is the priority. A Y1 call from the FAH zone is present at the control board. When SW3 numbers 4 and 5 are both in the ON position, the unit will operate in the hydronic mode for five minutes. If the hydronic call is not satisfied within the five minutes, the unit will switch to FAH mode. When FAH is satisfied, the unit will switch back to hydronic. (See Override Selection DIP Switches table.)

ComforTalk and FaultFlash Thermostats

When the heat pump microprocessor control is configured for ComforTalk or FaultFlash (SW2-8 'off') thermostats the thermostats will flash or display alert codes when a lockout condition is present. SW2-8 in the 'on' position configures the control to operate with typical thermostats (continuous lockout signal).

FaultFlash Thermostats

Thermostat Display Lockout Code	Lockout Description
2 Flashes	High Pressure Fault
3 Flashes	Low Pressure Fault
4 Flashes	Not Applicable
5 Flashes	Water Flow Fault
6 Flashes	Not Applicable
7 Flashes	Condensate Fault
8 Flashes	Voltage Out of Range
9 Flashes	RPM Fault

The tables below show the codes that will be displayed on the different ComforTalk and FaultFlash thermostats.

ComforTalk Thermostats

Thermostat Display Lockout Code	Lockout Description
"High Pressure" or "E2"	High Pressure Fault
"Low Pressure" or "E3"	Low Pressure Fault
"E4"	Not Applicable
"Water Flow" or "E5"	Water Flow Fault
"E6"	Not Applicable
"Condensate" or "E7"	Condensate Fault
"Voltage Range" or "E8"	Voltage Out of Range
"RPM" or "E9"	RPM Fault

These thermostats can be configured to display the lockout condition "text" or error number.

* A slow flash of 1 second on and off means the heat pump microprocessor SW2-1 is configured for "Test Mode".

Microprocessor Control cont.

Airflow Selection DIP Switches (SW1)

See Blower Performance Data section.

Factory Setup DIP Switches (SW2)				
DIP Switch Number		Description	OFF Position	ON Position
SW2-	1	Service Test Mode Allows field selection of "NORMAL" or "TEST" operational modes. Test mode accelerates most timing functions 16 times to allow faster troubleshooting. Test mode also allows viewing the "CURRENT" status of the fault inputs on the LED display.	Test Mode	Normal Speed Operation
SW2-	2	Freeze Detection Limit Allows field selection of freeze detection thermistor fault sensing for well water (30°F) or antifreeze protected (15°F) earth loops.	Low Loop Water Temperature Sensing Set at 15°F	Low Well Water Temperature Sensing Set at 30°F
SW2-	3	Forced Air Heating/Hydronic Heating This switch allows field selection of "Heating Forced Air Priority" or "Hydronic Priority".	Forced Air Heating Priority	Hydronic Heating Priority
SW2-	4	Forced Air Cooling/Hydronic Heating This switch allows field selection of "Cooling Forced Air Priority" or "Hydronic Priority".	Forced Air Cooling Priority	Hydronic Heating Priority
SW2-	5	Not Used	Not Applicable	Not Applicable
SW2-	6	Diagnostics Inputs Allows viewing the inputs from the thermostat to the control board such as Y1, Y2, O, G, W, HW, SL1-In, on the LED display..	Inputs	Normal
SW2-	7	Diagnostics Outputs Allows viewing the outputs from the control board such as compressor, diverting valve, reversing valve, blower, hot water pump and loop pump on the LED display.	Outputs	Normal
SW2-	8	Thermostat Selection Configures the control for a pulsed lockout signal (ComforTalk and FaultFlash thermostats) or continuous lockout signal (standard thermostat).	Pulse "L" Signal	Continuous "L" Signal

Factory Setup DIP Switches (SW3)				
DIP Switch Number		Description	OFF Position	ON Position
SW3-	1	Dual Capacity/Single Speed Configures the control for single speed compressor operation or dual capacity operation.	Dual Capacity Operation	Single Speed Operation
SW3-	2	POPC/Spring This switch allows field selection of "Power Open, Power Closed" dampers or "Power Open, Spring Close" dampers.	Power Open, Power Close	Power Open, Spring Close
SW3-	3	No RPM/RPM Configures the control to monitor the RPM output of an ECM blower motor. This product must have the control configured for "NO RPM" sensing.	ECM Blower/RPM Monitoring Disable	Not Used
SW3-	4	Override Time Configures the control override timings when switching from forced air mode to hydronic mode or vice versa.	See Override Selection table below for timings	See Override Selection table below for timings
SW3-	5	Override Time Configures the control override timings when switching from forced air mode to hydronic mode or vice versa.	See Override Selection table below for timings	See Override Selection table below for timings

LED Status Board DIP Switches (SW4)				
DIP Switch Number		Description	OFF Position	ON Position
SW4-	1	Hydronic Mode Enables and disables hydronic heating mode.	Hydronic Heating Disabled	Hydronic Heating Enabled

Override Selection DIP Switches

Override Time	SW3-4	SW3-5
5 minutes	On	On
10 minutes	Off	On
30 minutes	On	Off
60 minutes	Off	Off

Operation Logic

	Heating				Cooling		Hot Water Mode
	STG1	STG2	STG3	EMERG	STG1	STG2	
Compressor	On	On	On	Off	On	On	Stg 2 On
Reversing Valve	Off	Off	Off	Off	On	On	Off
Loop Pump	On	On	On	Off	On	On	On
Load Pump	Off	Off	Off	Off	Off	Off	On
Aux Heater	Off	Off	Staged	Staged	Off	Off	Off
Acc Relay	On	On	On	Off	On	On	Off
Diverting Valve	Off	Off	Off	Off	Off	Off	On
ECM Speed	On	On	On	On	On	On	Off
T-Stat Signal	Y1	Y1, Y2	Y1, Y2, W	W	Y1, O	Y1, Y2, O	HW
Damper	Off	Off	Off	On	Off	Off	Off
Auxiliary 1 - Out	On	On	On	Off	On	On	On

Wiring Schematics

208-230/60/1 ECM

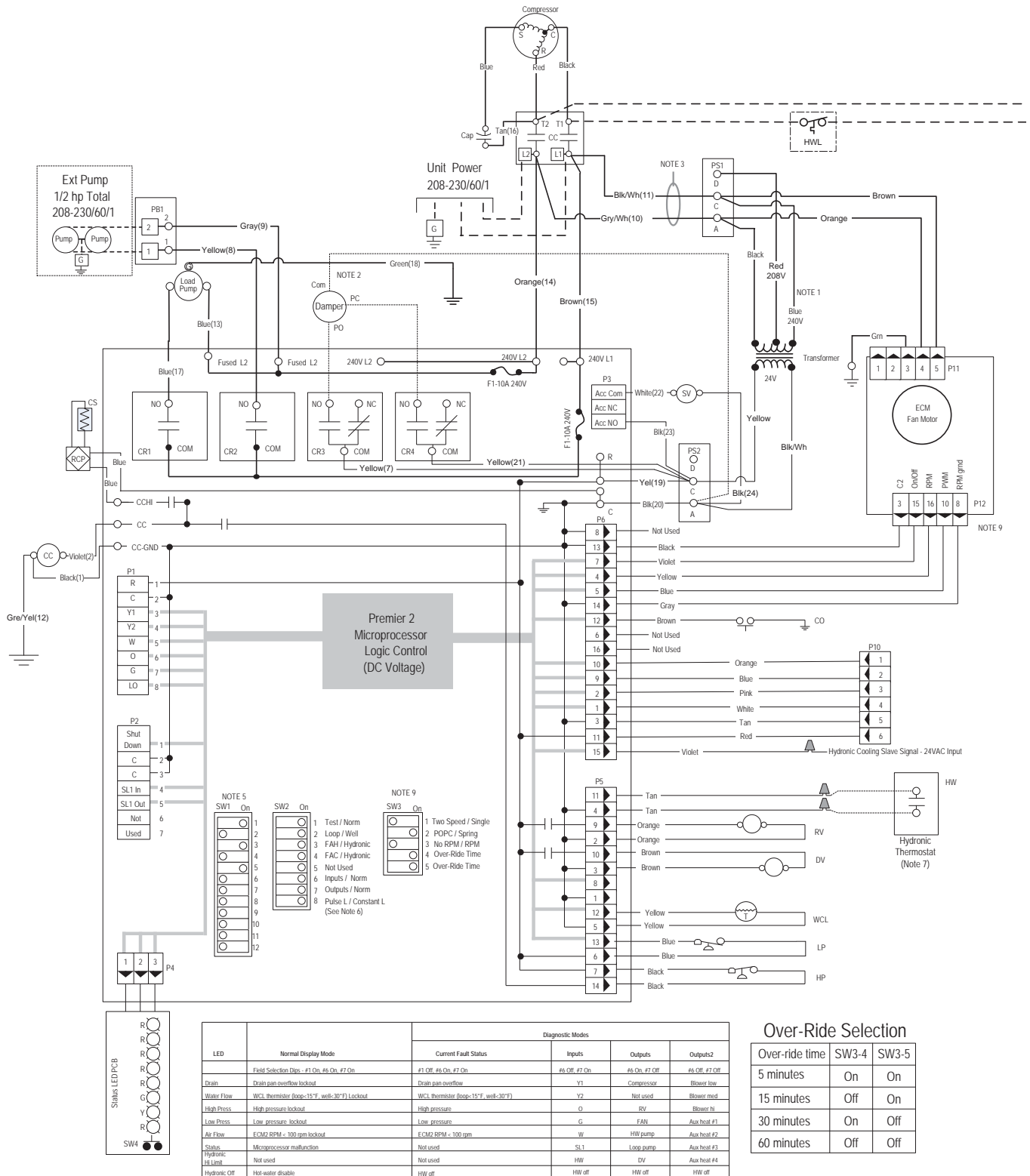

Over-Ride Selection

Over-ride time	SW3-4	SW3-5
5 minutes	On	On
15 minutes	Off	On
30 minutes	On	Off
60 minutes	Off	Off

Wiring Schematics cont.

208-230/60/1 ECM cont.

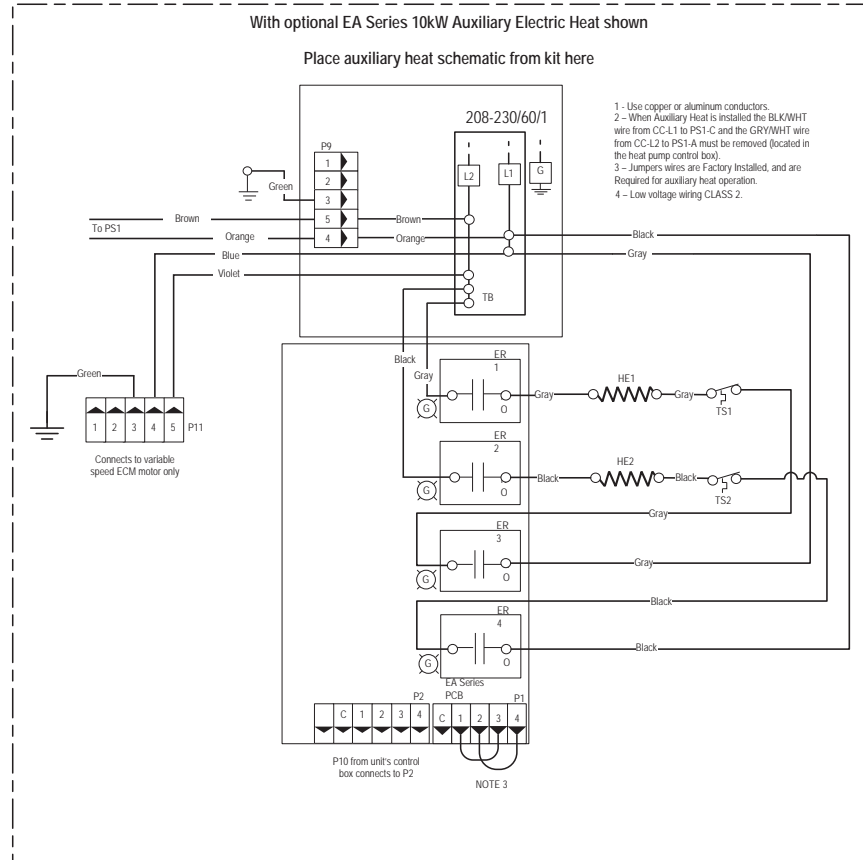
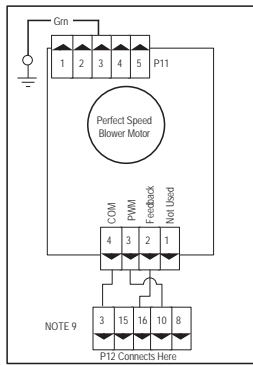
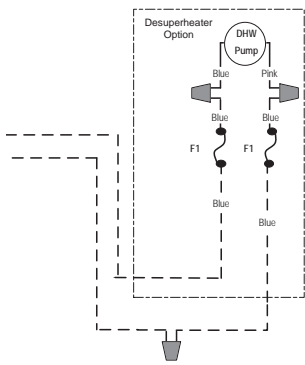

Legend

	Breaker		Thermistor
	Factory Low voltage wiring		Light emitting diode - Green
	Factory Line voltage wiring		Relay coil
	Field low voltage wiring		Capacitor w/ bleed resistor
	Field line voltage wiring		Switch - Condensate overflow
	Optional block		Switch - High pressure
	DC Voltage PCB traces		Switch - Low pressure
	Internal junction		Switch - Hot Water On/Off
	Quick connect terminal		Polarized connector
	Wire nut		
	Field wire lug		
	Ground		
	Relay Contacts - N.O., N.C.		
	Fuse		

CC - Compressor Contactor	PB1, PB2 - Power blocks
CO - Condensate overflow sensor	PR - Pump Relay
CR1 - DHW pump relay	PS - Power strip
CR2 - Loop pump relay	RV - Reversing Valve coil
CR3 - PSC Fan Speed Relay	SW1 - DIP package 12 position
CR4 - PSC Fan Power Relay	SW2 - DIP package 8 position
CS - Compressor Solenoid	SW3 - DIP package 5 position
F1 and F2 - Fuses	SW4 - Hot water pump enable switch
HE - Heater element	TS - Thermal limit switch
HP - High pressure switch	HWL - Hot Water Limit Sensor
ER1 to ER4 - Aux heat stage relays	WCL - Water Coil Limit Sensor
LP - Low pressure switch	

Operation Logic Data

Operation Logic Table	Heating				Cooling		Hot Water Mode
	STG1	STG2	STG3	EMERG	STG1	STG2	
Compressor	On	On	On	Off	On	On	Stg 2 On
Reversing Valve	Off	Off	Off	Off	On	On	Off
Loop Pump	On	On	On	On	On	On	On
Load Pump	Off	Off	Off	Off	Off	Off	On
Aux Heater	Off	Off	Staged	Staged	Off	Off	Off
Acc Relay	On	On	On	Off	On	On	Off
Diverting Valve	Off	Off	Off	Off	Off	Off	Off
ECM Speed	On	On	On	On	On	On	Off
T-Stat Signal	Y1	Y1, Y2	Y1, Y2, W	W	Y1, O	Y1, Y2, O	HW
Damper	Off	Off	Off	On	Off	Off	Off
Auxiliary 1 - Out	On	On	On	Off	On	On	On

Notes

- 1 - Switch blue and red wires for 208V operation.
- 2 - Typical hook-up shown for power open - power closed damper shown.
- 3 - The blk/wht and gray/wht wires are removed when Aux Heat is installed
- 4 - Use part number 19P592-01 (jumper bar assembly) when single source power is required.
- 5 - Air Flow Configuration Example: SW1 configured for dip 1 as low, dip 3 as medium, and dip 5 as high speed ECM fan.
- 6 - SW2-8 must be in the OFF position for pulsed "L" lockout signal and in the ON position for constant "L" lockout signal.
- 7 - A hydronic input will generate a Y2 compressor call so that compressor only operates in high capacity.
- 8 - Low voltage wiring CLASS 2.
- 9 - On units with a Perfect Speed ECM blower motors, the blower's low voltage harness from the board with the P12 connector will connect to a jumper harness that is connected to the blower motor. SW3-3 DIP switch should be set in the OFF position.

Wiring Schematics cont.

208-230/60/1 ECM with IntelliStart

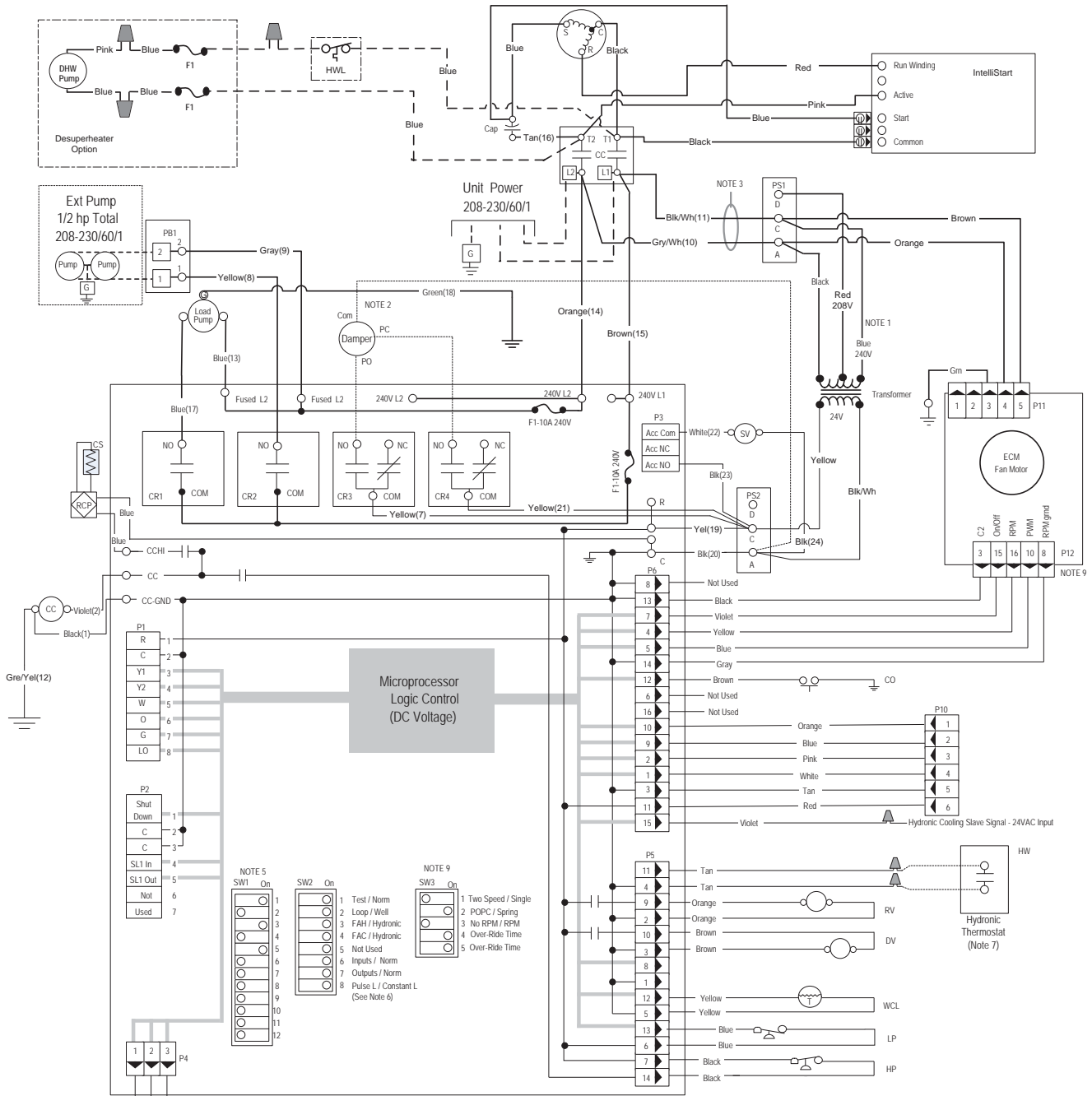

LED	Normal Display Mode	Diagnostic Modes			
		Current Fault Status	Inputs	Outputs	Outputs2
	Field Selection Dips: #1 On, #6 On, #7 On	#1 Off, #6 On, #7 On	#6 Off, #7 On	#6 On, #7 Off	#6 Off, #7 Off
Drain	Drain pan overflow lockout	Drain pan overflow	Y1	Compressor	Blower low
Water Flow	WCL thermostat (loop-15°F, week-30°F) Lockout	WCL thermostat (loop-15°F, week-30°F)	Y2	Not used	Blower med
High Press	High pressure lockout	High pressure	O	RV	Blower hi
Low Press	Low pressure lockout	Low pressure	G	FAN	Aux heat #1
Air Flow	ECM2 RPM - 100 gpm lockout	ECM2 RPM - 100 gpm	W	HW pump	Aux heat #2
Status	Microprocessor malfunction	Not used	SL1	Loop pump	Aux heat #3
Hydronic	Not used	Not used	HW	DV	Aux heat #4
Hydronic Off	Hot-water disable	HW off	HW off	HW off	HW off

Over-Ride Selection

Over-ride time	SW3-4	SW3-5
5 minutes	On	On
15 minutes	Off	On
30 minutes	On	Off
60 minutes	Off	Off

Wiring Schematics cont.

208-230/60/1 ECM with IntelliStart cont.

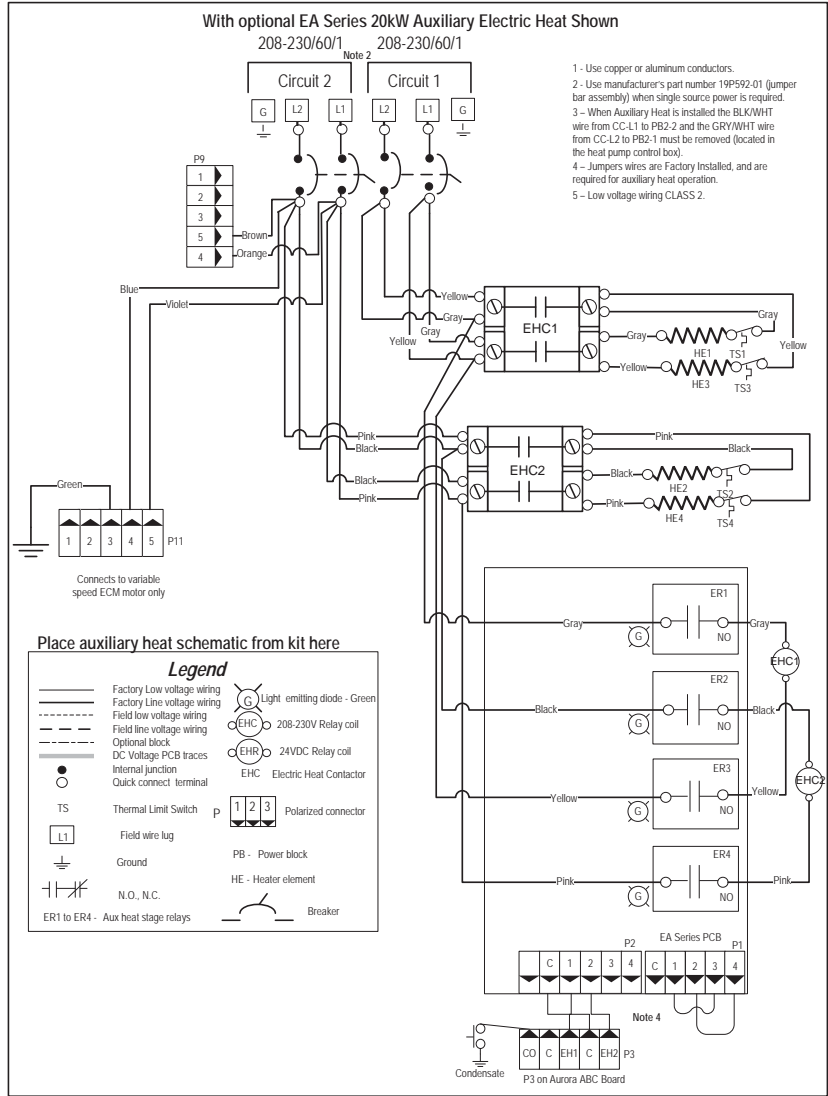
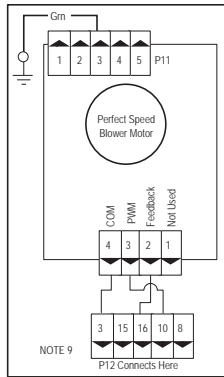

- 1 - Use copper or aluminum conductors.
- 2 - Use manufacturer's part number 19P592-01 (Jumper bar assembly) when single source power is required.
- 3 - When Auxiliary Heat is installed the BLK/WHY wire from CC-L1 to PB2-2 and the GRY/WHY wire from CC-L2 to PB2-1 must be removed (located in the heat pump control box).
- 4 - Jumpers wires are Factory Installed, and are required for auxiliary heat operation.
- 5 - Low voltage wiring CLASS 2.

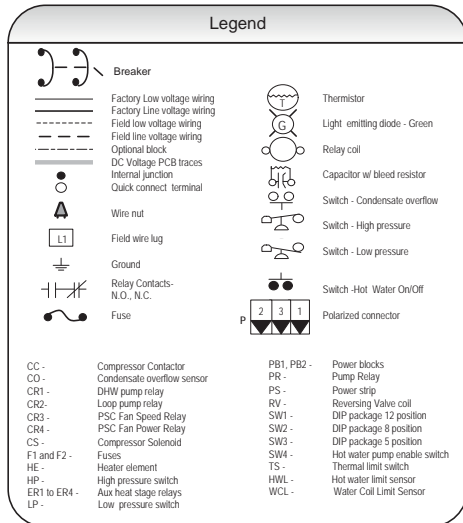

Operation Logic Data

Operation Logic Table	Heating				Cooling		Hot Water Mode
	STG1	STG2	STG3	EMERG	STG1	STG2	
Compressor	On	On	On	Off	On	On	Stg 2 On
Reversing Valve	Off	Off	Off	Off	On	On	Off
Loop Pump	On	On	On	Off	On	On	On
Load Pump	Off	Off	Off	Off	Off	Off	On
Aux Heater	Off	Off	Staged	Staged	Off	Off	Off
Acc Relay	On	On	On	Off	On	On	Off
Diverting Valve	Off	Off	Off	Off	Off	Off	On
ECM Speed	On	On	On	On	On	On	Off
T-Stat Signal	Y1	Y1, Y2	Y1, Y2, W	W	Y1, O	Y1, Y2, O	HW
Damper	Off	Off	Off	Off	Off	Off	Off
Auxiliary 1 - Out	On	On	On	Off	On	On	On

- Notes
- 1 - Switch blue and red wires for 208V operation.
 - 2 - Typical hook-up shown for power open - power closed damper shown.
 - 3 - The blk/wh and gray/wh wires are removed when Aux Heat is installed
 - 4 - Use part number 19P592-01 (Jumper bar assembly) when single source power is required.
 - 5 - Air Flow Configuration Example: SW1 configured for dip 1 as low, dip 3 as medium, and dip 5 as high speed ECM fan.
 - 6 - SW2-8 must be in the OFF position for "putted 'L' lockout signal and in the ON position for "constant 'L' lockout signal.
 - 7 - A hydronic input will generate a Y2 compressor call so that compressor only operates in high capacity.
 - 8 - Low voltage wiring CLASS 2.
 - 9 - On units with a Perfect Speed ECM blower motors, the blower's low voltage harness from the board with the P12 connector will connect to a jumper harness that is connected to the blower motor. SW3-3 DIP switch should be set in the OFF position.

Unit Startup

Before powering unit, check the following:

- Fuses, breakers and wire size are correct and match the name plate.
- Low voltage wiring is complete.
- Black/white and gray/white wires in unit control box have been removed if auxiliary heat has been installed.
- DIP switches are set correctly. SW3-3 must be in “OFF” position.
- Piping has been completed and the water system is cleaned and flushed.
- Air is purged from the closed loop system.
- Air is purged from buffer tank, hydronic system isolation valves are open, and water control valves or loop pumps are wired.
- Condensate line is open and correctly pitched.
- Blower rotates freely and foam shipping support has been removed.
- Blower speed is correct (DIP switch setting).
- Air filter is clean and in position.
- Service/access panels are in place.
- Return air temperature is between 60-80°F in heating and 70-95°F in cooling.
- Air coil is clean.

Hydronic Startup Instructions

1. Initiate a control signal to place the unit in the hydronic heating mode. Heating setpoint must be above the water temperature of the buffer tank and/or load side water loop.
2. Be sure that the water control valve or loop pumps are activated.
3. The compressor and load side circulating pump will energize after a time delay.
4. Using a digital thermometer measure the load side water entering the Synergy3D unit.

NOTE: Ensure that the sensing probe is in contact with copper piping and that it is well insulated to prevent measurement errors due to ambient room temperature. Allow 2-3 minutes before measurement for best results.

5. Using a digital thermometer, measure the load-side water temperature leaving the Synergy3D unit. Refer to Operating Parameters table and compare measured temperature rise with data.
6. Adjust the heating setpoint below the water temperature of the buffer tank and/or load side water. Verify that the compressor, load side circulating pump and water control valve or loop pumps deactivate.
7. During test, check for excessive vibration, noise or water leaks. Correct or repair as required.
8. Set system to desired normal operating temperature to maintain desired comfort level.

9. Instruct the owner/operator in the proper operation of the hydronic temperature control and system maintenance.

Forced Air Startup Instructions

NOTE: On initial power-up a four-minute time delay will occur.

1. Initiate a control signal to energize the blower motor. Check blower operation.
2. Initiate a control signal to place the unit in the cooling mode. Cooling setpoint must be set below room temperature.
3. First stage cooling will energize after a time delay.
4. Be sure that the compressor and water control valve or loop pumps are activated.
5. Verify that the water flow rate is correct by measuring the pressure drop through the heat exchanger using the P/T plugs and comparing to water Pressure Drop table.
6. Check the temperature of both the supply and discharge water. Refer to Operating Parameters tables.
7. Check for an air temperature drop of 15° to 25° F across the air coil, depending on the blower speed and entering water temperature. Refer to Operating Parameters tables.
8. Adjust the cooling setpoint above the room temperature and verify that the compressor and water valve or loop pumps deactivate.
9. Initiate a control signal to place the unit in the heating mode. Heating setpoint must be set above room temperature.
10. First stage heating will energize after a time delay.
11. Check for an air temperature rise of 20° to 35° F across the air coil, depending on the blower speed and entering water temperature. Refer to Operating Parameters tables.
12. If auxiliary electric heaters are installed, adjust the heating setpoint until the electric heat banks are sequenced on. All stages of the auxiliary heater should be sequenced on when the thermostat is in the “Emergency Heat” mode. Check amperage of each element.
13. Adjust the heating setpoint below room temperature and verify that the compressor and water valve or loop pumps deactivate.
14. During all testing, check for excessive vibration, noise or water leaks. Correct or repair as required.
15. Set system to desired normal operating mode and set temperature to maintain desired comfort level.
16. Instruct the owner/operator in the proper operation of the thermostat and system maintenance.

Operating Parameters

Synergy3D 1st Stage Operating Parameters 038-072

EWT °F	Water Flow (GPM/ Ton)	Forced Air Cooling						Forced Air Heating								
		Suction Pressure PSIG	Discharge Pressure PSIG	Super-heat °F	Sub-cooling °F	Water Temp Rise °F	Air Temp Drop °F DB	Suction Pressure PSIG	Discharge Pressure PSIG	Super-heat °F	Sub-cooling °F	Water Temp Rise °F	Air Temp Drop °F DB			
20	1.5	Operation Not Recommended						Operation Not Recommended								
	2.25													57-64		
30	1.5	Operation Not Recommended						Operation Not Recommended								
	2.25													108-113	141-178	22° - 40°
50	1.5	141-156	170-222	9° - 19°	7° - 18°	8-15	18-25	125-136	271-320	10° - 17°	4° - 17°	4 - 10		21-29		
	2.25	130-146	188-224	7° - 17°	7° - 18°	7-12	22-26	107-122	288-326	7° - 15°	4° - 17°	4 - 9		20-29		
70	1.5	152-162	232-242	7° - 15°	8° - 18°	7-18	18-23	163-185	301-357	12° - 21°	4° - 17°	6 - 10		22-28		
	2.25	139-151	247-281	7° - 14°	8° - 18°	6-14	18-25	147-162	321-368	9° - 13°	4° - 17°	5 - 9		28-36		
90	1.5	155-168	311-335	7° - 18°	9° - 18°	8-19	17-21	195-215	320-392	12° - 24°	2° - 14°	8 - 12		23-32		
	2.25	141-155	327-361	6° - 14°	9° - 18°	9-15	18-23	177-202	351-398	9° - 18°	2° - 14°	6-10		32-42		
110	1.5	Operation Not Recommended						Operation Not Recommended								
	2.25													145-164	421-453	6° - 12°
3.0	133-149	439-481	6° - 12°	10° - 20°	7-11	18-22	Operation Not Recommended									
120	1.5	Operation Not Recommended											Operation Not Recommended			
	2.25							145-158	481-511	6° - 12°	10° - 20°	8-14				
3.0	139-151	491-528	6° - 12°	10° - 20°	5-12	17-21	Operation Not Recommended									

NOTES: Based on Nominal 400 cfm per ton airflow and 70°F EAT heating and 80/67°F EAT cooling
Cooling air and water numbers can vary greatly with changes in humidity
No Hot Water Generator

Synergy3D 2nd Stage Operating Parameters 038-072

EWT °F	Water Flow (GPM/ Ton)	Forced Air Cooling						Forced Air Heating								
		Suction Pressure PSIG	Discharge Pressure PSIG	Super-heat °F	Sub-cooling °F	Water Temp Rise °F	Air Temp Drop °F DB	Suction Pressure PSIG	Discharge Pressure PSIG	Super-heat °F	Sub-cooling °F	Water Temp Rise °F	Air Temp Drop °F DB			
20	1.5	Operation Not Recommended						Operation Not Recommended								
	2.25													57-64		
30	1.5	Operation Not Recommended						Operation Not Recommended								
	2.25													118-114	144-182	22° - 40°
50	1.5	144-159	172-225	9° - 19°	7° - 18°	8-15	18-25	127-139	273-325	10° - 17°	4° - 17°	4 - 9		21-29		
	2.25	133-149	191-228	7° - 17°	7° - 18°	7-12	22-26	111-126	292-330	6° - 15°	4° - 17°	4 - 8		20-29		
70	1.5	155-166	234-246	8° - 15°	8° - 18°	7-16	18-23	166-189	305-361	12° - 21°	4° - 17°	6 - 10		22-28		
	2.25	142-155	253-289	7° - 14°	8° - 18°	6-13	18-25	151-168	326-371	6° - 13°	4° - 17°	5 - 9		28-36		
90	1.5	157-170	313-338	7° - 18°	9° - 18°	8-19	17-21	198-219	322-398	12° - 24°	2° - 14°	8 - 12		23-32		
	2.25	147-159	331-365	7° - 14°	9° - 18°	6-13	18-23	181-206	355-402	9° - 18°	2° - 14°	6-10		32-42		
110	1.5	Operation Not Recommended						Operation Not Recommended								
	2.25													148-167	425-458	7° - 12°
3.0	143-157	444-485	6° - 12°	10° - 20°	7-11	18-22	Operation Not Recommended									
120	1.5	Operation Not Recommended											Operation Not Recommended			
	2.25							149-160	487-519	7° - 12°	10° - 20°	8-19				
3.0	144-156	496-534	6° - 12°	10° - 20°	5-12	17-21	Operation Not Recommended									

NOTES: Based on Nominal 400 cfm per ton airflow and 70°F EAT heating and 80/67°F EAT cooling
Cooling air and water numbers can vary greatly with changes in humidity
No Hot Water Generator

Synergy3D 038-072

EWT °F	80°F ELT				100°F ELT				120°F ELT			
	Suction Pressure PSIG	Discharge Pressure PSIG	Super-heat °F	Sub-cooling °F	Suction Pressure PSIG	Discharge Pressure PSIG	Super-heat °F	Sub-cooling °F	Suction Pressure PSIG	Discharge Pressure PSIG	Super-heat °F	Sub-cooling °F
30	69-82	275-311	9° - 17°	10° - 19°	71-84	368-407	8° - 15°	10° - 19°	73-88	462-502	10° - 19°	11° - 19°
50	103-117	288-327	9° - 18°	13° - 20°	106-122	380-419	8° - 16°	13° - 20°	110-124	472-512	7° - 14°	9° - 20°
70	139-153	300-343	11° - 17°	15° - 24°	142-157	394-432	8° - 17°	15° - 24°	148-162	483-523	8° - 15°	7° - 24°

NOTES: Water Heating mode allows only high capacity compressor operation.
No Hot Water Generator

Pressure Drop

Model	gpm	Pressure Drop (psi)				
		30°F	50°F	70°F	90°F	110°F
038 full load	5	1.2	1.2	1.1	1.0	1.0
	7	2.2	2.1	1.9	1.8	1.7
	9	3.4	3.2	3.0	2.8	2.6
	11	4.9	4.6	4.3	4.0	3.7
038 part load	4	0.9	0.8	0.8	0.7	0.7
	6	1.7	1.6	1.5	1.4	1.3
	8	2.8	2.6	2.5	2.3	2.1
	10	4.2	3.9	3.7	3.4	3.2
049 full load	6	1.2	1.2	1.1	1.0	1.0
	9	2.4	2.2	2.1	2.0	1.8
	12	3.9	3.6	3.4	3.2	2.9
	15	5.7	5.3	5.0	4.7	4.3
049 part load	5	1.1	1.1	1.0	0.9	0.9
	8	2.0	1.8	1.7	1.6	1.5
	11	3.4	3.1	2.9	2.8	2.5
	14	5.0	4.7	4.4	4.1	3.8
064 full load	8	2.0	1.8	1.7	1.6	1.5
	12	3.6	3.3	3.2	3.0	2.6
	16	6.5	6.0	5.6	5.2	4.8
	20	9.7	9.1	8.5	8.0	7.4
064 part load	6	1.2	1.2	1.1	1.0	1.0
	10	2.6	2.5	2.3	2.1	2.0
	14	5.0	4.7	4.4	4.1	3.8
	18	8.1	7.6	7.1	6.6	6.1
072 full load	12	3.6	3.3	3.2	3.0	2.6
	15	5.7	5.3	5.0	4.7	4.3
	18	8.1	7.6	7.1	6.6	6.1
	21	10.8	10.1	9.5	8.9	8.2
072 part load	10	2.6	2.5	2.3	2.1	2.0
	13	4.1	4.0	3.7	3.4	3.3
	16	6.5	6.0	5.8	5.4	5.0
	19	8.9	8.4	7.9	7.4	6.9

6/8/11

Compressor Resistance

Model	Compressor Model No.	208-230/60/1	
		Run	Start
038	ZPS30K5E-PFV	0.81 - 0.94	1.41 - 1.63
049	ZPS40K5E-PFV	0.48 - 0.55	1.72 - 1.99
064	ZPS51K5E-PFV	0.36 - 0.42	1.51 - 1.74
072	ZPS60K5E-PFV	0.31 - 0.36	1.72 - 1.98

9/24/2013

Thermistor Resistance

Thermistor Temperature (°F)	Microprocessor Resistance (Ohms)
5	75757-70117
14	57392-53234
23	43865-40771
32	33809-31487
41	26269-24513
50	20570-19230
59	16226-15196
68	12889-12093
77	10310-9688
86	8300-7812
95	6723-6337
104	5480-5172
113	4490-4246
122	3700-3504
131	3067-2907
140	2554-2424
149	2149-2019

Heat of Extraction/Rejection

Model		GPM	Heat of Extraction (kBtuh)				Heat of Rejection (kBtuh)				
			30°F	50°F	70°F	90°F	30°F	50°F	70°F	90°F	110°F
038	Part Load	4.0		18.5	25.1	30.9		34.8	33.5	32.1	
		6.0	12.0	19.1	26.4	32.8	29.4	34.9	33.6	32.1	30.4
		8.0	12.9	20.1	27.1	32.8	29.8	35.4	34.1	32.5	30.7
	Full Load	5.0		25.6	33.2	38.7		50.0	47.7	45.0	
		7.0	18.9	26.7	34.9	41.4	44.8	50.5	48.3	45.9	43.4
		9.0	19.3	27.4	36.1	42.8	45.0	50.8	48.6	46.1	43.6
049	Part Load	5.0		24.2	31.0	35.6		46.9	45.0	43.1	
		8.0	18.5	26.6	34.2	39.6	40.6	46.9	44.6	42.5	39.9
		11.0	19.2	27.7	36.0	42.2	40.0	46.9	44.9	43.2	40.8
	Full Load	6.0		31.3	39.4	43.7		55.5	53.3	50.3	
		9.0	23.2	32.5	41.5	46.6	48.7	55.6	53.8	51.3	49.6
		12.0	23.6	33.4	42.8	48.3	48.8	55.7	54.1	51.4	49.8
064	Part Load	6.0		29.8	39.4	46.0		60.4	57.8	54.7	
		10.0	19.5	30.1	41.1	49.7	53.4	60.2	57.9	55.0	51.5
		14.0	20.5	31.2	42.0	49.7	53.3	60.3	58.0	55.3	51.8
	Full Load	8.0		40.5	52.5	61.7		81.5	80.7	77.1	
		12.0	30.8	43.4	54.9	62.7	73.5	81.9	81.2	77.3	72.5
		16.0	31.2	44.3	56.6	65.4	73.9	82.4	81.6	77.8	72.6
072	Part Load	10.0		37.8	48.3	56.7		69.8	69.3	64.5	
		13.0	26.3	38.2	50.3	61.2	63.6	69.7	69.3	64.8	60.0
		16.0	23.9	39.6	52.7	61.8	63.3	71.3	69.7	65.5	62.5
	Full Load	12.0		49.1	63.8	74.6		93.3	94.3	89.0	
		15.0	37.6	52.5	66.5	75.8	83.6	93.7	94.6	89.2	84.4
		18.0	37.9	53.6	68.6	79.0	84.1	94.3	95.2	89.6	84.6

10/1/2013

Antifreeze Corrections

Catalog performance can be corrected for antifreeze use. Please use the following table and note the example given.

Antifreeze Type	Antifreeze % by wt	Heating	Cooling	Pressure Drop
EWT - °F [°C]		30 [-1.1]	90 [32.2]	30 [-1.1]
Water	0	1.000	1.000	1.000
Ethylene Glycol	10	0.973	0.991	1.075
	20	0.943	0.979	1.163
	30	0.917	0.965	1.225
	40	0.890	0.955	1.324
	50	0.865	0.943	1.419
Propylene Glycol	10	0.958	0.981	1.130
	20	0.913	0.969	1.270
	30	0.854	0.950	1.433
	40	0.813	0.937	1.614
	50	0.770	0.922	1.816
Ethanol	10	0.927	0.991	1.242
	20	0.887	0.972	1.343
	30	0.856	0.947	1.383
	40	0.815	0.930	1.523
	50	0.779	0.911	1.639
Methanol	10	0.957	0.986	1.127
	20	0.924	0.970	1.197
	30	0.895	0.951	1.235
	40	0.863	0.936	1.323
	50	0.833	0.920	1.399



WARNING: Gray area represents antifreeze concentrations greater than 35% by weight and should be avoided due to the extreme performance penalty they represent.

Antifreeze Correction Example

Antifreeze solution is Propylene Glycol 20% by weight. Determine the corrected heating and cooling performance at 30°F and 90°F respectively as well as pressure drop at 30°F for a Synergy3D Model 038.

The corrected cooling capacity at 90°F would be: 36,800 MBtu/h x 0.969 = 35,659 MBtu/h

The corrected heating capacity at 30°F would be: 26,600 MBtu/h x 0.913 = 24,286 MBtu/h

The corrected pressure drop at 30°F and 9 gpm would be: 7.9 feet of head x 1.270 = 10.03 feet of head

Correction Factor Tables

Air Flow Corrections (Dual Capacity Part Load)

Airflow		Cooling				Heating		
CFM Per Ton of Clg	% of Nominal	Total Cap	Sens Cap	Power	Heat of Rej	Htg Cap	Power	Heat of Ext
240	60	0.922	0.778	0.956	0.924	0.943	1.239	0.879
275	69	0.944	0.830	0.962	0.944	0.958	1.161	0.914
300	75	0.957	0.866	0.968	0.958	0.968	1.115	0.937
325	81	0.970	0.900	0.974	0.970	0.977	1.075	0.956
350	88	0.982	0.933	0.981	0.980	0.985	1.042	0.972
375	94	0.991	0.968	0.991	0.991	0.993	1.018	0.988
400	100	1.000	1.000	1.000	1.000	1.000	1.000	1.000
425	106	1.007	1.033	1.011	1.008	1.007	0.990	1.010
450	113	1.013	1.065	1.023	1.015	1.012	0.987	1.018
475	119	1.017	1.099	1.037	1.022	1.018	0.984	1.025
500	125	1.020	1.132	1.052	1.027	1.022	0.982	1.031
520	130	1.022	1.159	1.064	1.030	1.025	0.979	1.034

5/30/06

Air Flow Corrections (Dual Capacity Full Load & Single Speed)

Airflow		Cooling				Heating		
CFM Per Ton of Clg	% of Nominal	Total Cap	Sens Cap	Power	Heat of Rej	Htg Cap	Power	Heat of Ext
240	60	0.922	0.786	0.910	0.920	0.943	1.150	0.893
275	69	0.944	0.827	0.924	0.940	0.958	1.105	0.922
300	75	0.959	0.860	0.937	0.955	0.968	1.078	0.942
325	81	0.971	0.894	0.950	0.967	0.977	1.053	0.959
350	88	0.982	0.929	0.964	0.978	0.985	1.031	0.973
375	94	0.992	0.965	0.982	0.990	0.993	1.014	0.988
400	100	1.000	1.000	1.000	1.000	1.000	1.000	1.000
425	106	1.007	1.034	1.020	1.010	1.007	0.990	1.011
450	113	1.012	1.065	1.042	1.018	1.013	0.983	1.020
475	119	1.017	1.093	1.066	1.026	1.018	0.980	1.028
500	125	1.019	1.117	1.092	1.033	1.023	0.978	1.034
520	130	1.020	1.132	1.113	1.038	1.026	0.975	1.038

5/30/06

Cooling Capacity Corrections

Entering Air WB °F	Total Clg Cap	Sensible Cooling Capacity Multipliers - Entering DB °F										Power Input	Heat of Rejection
		60	65	70	75	80	80.6	85	90	95	100		
55	0.898	0.723	0.866	1.048	1.185	*	*	*	*	*	*	0.985	0.913
60	0.912		0.632	0.880	1.078	1.244	1.260	*	*	*	*	0.994	0.927
63	0.945			0.768	0.960	1.150	1.175	*	*	*	*	0.996	0.954
65	0.976			0.694	0.881	1.079	1.085	1.270	*	*	*	0.997	0.972
66.2	0.983			0.655	0.842	1.040	1.060	1.232	*	*	*	0.999	0.986
67	1.000			0.616	0.806	1.000	1.023	1.193	1.330	1.480	*	1.000	1.000
70	1.053				0.693	0.879	0.900	1.075	1.250	1.404	*	1.003	1.044
75	1.168					0.687	0.715	0.875	1.040	1.261	1.476	1.007	1.141

NOTE: *Sensible capacity equals total capacity at conditions shown.

03/28/12

Heating Capacity Corrections

Ent Air DB °F	Heating Corrections		
	Htg Cap	Power	Heat of Ext
45	1.062	0.739	1.158
50	1.050	0.790	1.130
55	1.037	0.842	1.096
60	1.025	0.893	1.064
65	1.012	0.945	1.030
68	1.005	0.976	1.012
70	1.000	1.000	1.000
75	0.987	1.048	0.970
80	0.975	1.099	0.930

11/10/09

Operating Limits

Operating Limits	Cooling		Heating	
	°F	°C	°F	°C
Air Limits				
Minimum Ambient Air	45	7.2	45	7.2
Rated Ambient Air	80	26.7	70	21.1
Max. Ambient Air	100	37.8	85	29.4
Minimum Entering Air	50	10.0	40	4.4
Rated Entering Air db/wb	80.6/66.2	27/19	68	20.0
Maximum Entering Air db/wb	110/83	43/28.3	80	26.7
Water Limits				
Minimum Entering Water	30	-1.1	20	-6.7
Normal Entering Water	50-110	10-43.3	30-70	-1.1
Maximum Entering Water	120	48.9	90	32.2

NOTES: Minimum/maximum limits are only for start-up conditions, and are meant for bringing the space up to occupancy temperature. Units are not designed to operate at the minimum/maximum conditions on a regular basis. The operating limits are dependant upon three primary factors: 1) water temperature, 2) return air temperature, and 3) ambient temperature. When any of the factors are at the minimum or maximum levels, the other two factors must be at the normal level for proper and reliable unit operation.

Reference Calculations

Heating Calculations:	Cooling Calculations:
$LWT = EWT - \frac{HE}{gpm \times 500}$	$LWT = EWT + \frac{HR}{gpm \times 500}$
$LAT = EAT + \frac{HC}{cfm \times 1.08}$	$LAT (DB) = EAT (DB) - \frac{SC}{cfm \times 1.08}$
$TH = HC + HW$	$LC = TC - SC$
	$S/T = \frac{SC}{TC}$

Legend and Notes

Abbreviations and Definitions

cfm = airflow, cubic feet/minute	kW = total power unit input, kilowatts
COP = Coefficient of Performance	LAT = leaving air temperature, °F
= Btu output/Btu input	LC = latent cooling capacity, MBtu/h
= $[HC / (kw \times 3.413)]$	LGPM = load flow in gallons per minute
EAT = entering air temperature, °F	LLT = leaving load fluid temperature from heat pump
EER = Energy Efficient Ratio	LST = leaving source fluid temperature from heat pump
= Btu output/Watt input	LWPD = load coax water pressure drop
ELT = entering load fluid temperature to heat pump	LWT = leaving water temperature, °F
EST = entering source fluid temperature to heat pump	PSI = pressure drop in pounds per square inch
EWT = entering water temperature (source) to heat pump	S/T = sensible to total cooling ratio
FT HD = pressure drop in feet of head	SC = sensible cooling capacity, MBtu/h
GPM = Gallons per minute	SWPD = source coax water pressure drop
WPD = water pressure drop, psi and feet of water	TC = total cooling capacity, MBtu/h
HC = air heating capacity, MBtu/h	TH = total heating capacity, MBtu/h
HE = total heat of extraction, MBtu/h	WPD = water pressure drop in PSI, feet of water
HR = total heat of rejection, MBtu/h	

Notes to Performance Data Tables

The following notes apply to all performance data tables:

- Performance ratings are based on 80°F DB/67°F WB EAT for cooling and 70°F DB EAT for heating.
- Three flow rates are shown for each unit. The lowest flow rate shown is used for geothermal open loop/well water systems with a minimum of 50°F EWT. The middle flow rate shown is the minimum geothermal closed loop flow rate. The highest flow rate shown is optimum for geothermal closed loop systems and the suggested flow rate for boiler/tower applications.
- The hot water generator numbers are based on a flow rate of 0.4 gpm/ton of rated capacity with an EWT of 90°F.
- Entering water temperatures below 40°F assumes 15% antifreeze solution.
- For non-standard EAT conditions, apply the appropriate Correction Factor tables.
- Interpolation between EWT, gpm, and cfm data is permissible, extrapolation is not.
- Pumping power is not included in the Performance Data tables nor are calculations for AHRI/ISO 13256-1.

Troubleshooting

Standard Microprocessor Controls

To check the unit control board for proper operation:

1. Disconnect thermostat wires at the control board.
2. Jumper the desired test input (Y1, Y2, W, O or G) to the R terminal to simulate a thermostat signal. To simulate a hot water call, jumper tan wires 11 and 14 on P5 connector.
3. If control functions properly:
 - Check for thermostat and field control wiring (use the diagnostic inputs mode).
4. If control responds improperly:
 - Ensure that component being controlled is functioning (compressor, blower, reversing valve, etc.).
 - Ensure that wiring from control to the component is functioning (refer to the LED Definition table below and use the diagnostic outputs mode).
 - If steps above check properly, replace unit control.

LED Definitions and Diagnostics

Standard Microprocessor

LED	NORMAL DISPLAY MODE		DIAGNOSTIC MODES							
			CURRENT FAULT STATUS		INPUTS		OUTPUTS 1		OUTPUTS 2	
	Field Selection DIPS									
	SW2-	1 On	SW2-	1 Off	SW2-	1 NA	SW2-	1 NA	SW2-	1 NA
	SW2-	6 On	SW2-	6 On	SW2-	6 Off	SW2-	6 On	SW2-	6 Off
	SW2-	7 On	SW2-	7 On	SW2-	7 On	SW2-	7 Off	SW2-	7 Off
Drain	Drain Pan Overflow Lockout		Drain Pan Overflow		Y1		Compressor (On or Low)		Blower Low	
Water Flow	FD Thermistor (Loop <15° F, Well<30°F) Lock-out		FD Thermistor (Loop <15° F, Well<30°F)		Y2		Compressor (On or High)		Blower Medium	
High Pressure	High Pressure >600 PSI Lockout		High Pressure >600		O		Reversing Valve		Blower High	
Low Pressure	Low Pressure <40 PSI Lockout		Low Pressure <40		G		Blower		Aux Heat 1	
Airflow	ECM RPM <100 RPM		ECM RPM <100 RPM		W		HW Pump		Aux Heat 2	
Status	Microprocessor Malfunction		Not Used		SL1		Loop Pump(s)		Aux Heat 3	
DHW Limit	Not Used		Not Used		HW		DV		Aux Heat 4	
DHW Off	Hot-Water Disable		HW Off		HW Off		HW Off		HW Off	

Refrigerant Systems

To maintain sealed circuit integrity, do not install service gauges unless unit operation appears abnormal. Compare the change in temperature on the air side as well as the water side to the information found in the Operation Parameters tables. If the unit's performance is not within the ranges listed, and the airflow and water flow are known to be correct, gauges should then be installed and superheat and subcooling numbers calculated. If superheat and subcooling are outside recommended ranges, an adjustment to the refrigerant charge may be necessary.

NOTE: Refrigerant tests must be made with hot water generator turned "OFF". Verify that air and water flow rates are at proper levels before servicing the refrigerant circuit.

Startup and Troubleshooting Form

Company Name: _____ Company Phone No: _____
 Technician Name: _____ Date: _____
 Model No: _____ Serial No: _____
 Owner's Name: _____ Open or Closed Loop: _____
 Installation Address: _____ Installation Date: _____

Check One

Start up/Check-out for new installation Troubleshooting Problem: _____

1. FLOW RATE IN GPM (SOURCE SIDE HEAT EXCHANGER)

Water In Pressure: a. _____ PSI
 Water Out Pressure: b. _____ PSI
 Pressure Drop = a - b c. _____ PSI
 Convert Pressure Drop to Flow Rate
 (refer to *Pressure Drop* table) d. _____ GPM

2. TEMPERATURE RISE OR DROP ACROSS SOURCE SIDE HEAT EXCHANGER

	COOLING	HEATING
Water In Temperature:	e. _____ °F	e. _____ °F
Water Out Temperature:	f. _____ °F	f. _____ °F
Temperature Difference:	g. _____ °F	g. _____ °F

3. TEMPERATURE RISE OR DROP ACROSS AIR COIL

	COOLING	HEATING
Supply Air Temperature:	h. _____ °F	h. _____ °F
Return Air Temperature:	i. _____ °F	i. _____ °F
Temperature Difference:	j. _____ °F	j. _____ °F

4. HEAT OF REJECTION (HR) / HEAT OF EXTRACTION (HE) CALCULATION

HR or HE = Flow Rate x Temperature Difference x Brine Factor*
 d. (above) x g. (above) x 485 for Methanol or Environol, 500 for water*
 Heat of Extraction (Heating Mode) = _____ btu/hr
 Heat of Rejection (Cooling Mode) = _____ btu/hr
 Compare results to Capacity Data Tables

Note: Steps 5 through 8 need only be completed if a problem is suspected

5. WATTS

	COOLING	HEATING	HYDRONIC
Volts:	m. _____ VOLTS	m. _____ VOLTS	m. _____ VOLTS
Total Amps (Comp. + Fan):	n. _____ AMPS	n. _____ AMPS	n. _____ AMPS
Watts = m. x n. x 0.85	o. _____ WATTS	o. _____ WATTS	o. _____ WATTS

6. CAPACITY

Cooling Capacity = HR. - (o. x 3.413) p. _____ btu/hr
 Heating Capacity= HE. + (o. x 3.413) p. _____ btu/hr

7. EFFICIENCY

Cooling EER = p. / o. q. _____ EER
 Heating COP = p. / (o. x 3.413) q. _____ COP

8. SUPERHEAT (S.H.) / SUBCOOLING (S.C.)

	COOLING	HEATING	HYDRONIC
Suction Pressure:	r. _____ PSI	r. _____ PSI	r. _____ PSI
Suction Saturation Temperature:	s. _____ °F	s. _____ °F	s. _____ °F
Suction Line Temperature:	t. _____ °F	t. _____ °F	t. _____ °F
Superheat = t. - s.	u. _____ °F	u. _____ °F	u. _____ °F
Head Pressure:	v. _____ PSI	v. _____ PSI	v. _____ PSI
High Pressure Saturation Temp.:	w. _____ °F	w. _____ °F	w. _____ °F
Liquid Line Temperature*:	x. _____ °F	x. _____ °F	x. _____ °F
Subcooling = w. - x.	y. _____ °F	y. _____ °F	y. _____ °F

* Note: Liquid line is between the source coax and the expansion valve in the cooling mode; between the air coil and the expansion valve in the heating mode; between hot water (load) coax and txv in hot water mode.

Heating Cycle Analysis

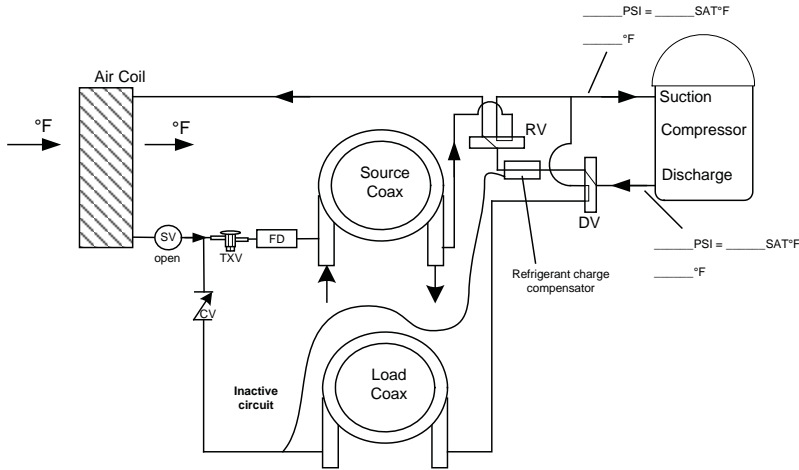

Unit Amp Draw _____
Line Voltage _____
Loop: _____ Open _____ Closed
Subcooling _____
Superheat _____

Entering Source Water _____ °F
Entering Water Pressure Drop _____ PSI
Leaving Source Water _____ °F
Leaving Water Pressure Drop _____ PSI

NOTE: Do not attach refrigerant gauges unless a problem is suspected!

Cooling Cycle Analysis

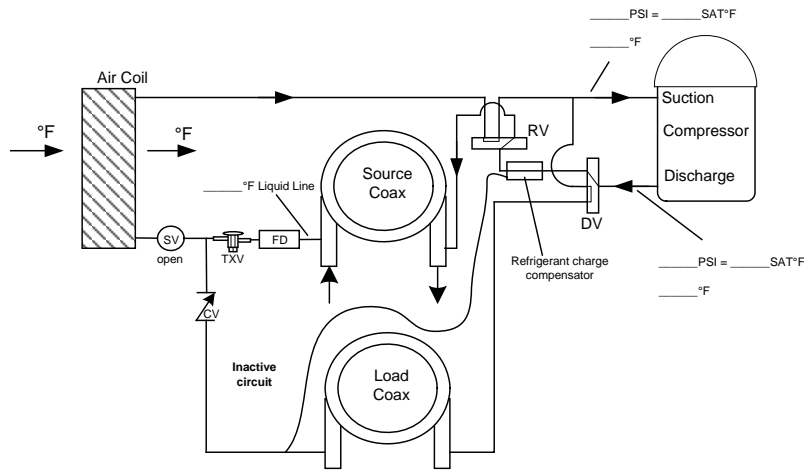

Unit Amp Draw _____
Line Voltage _____
Loop: _____ Open _____ Closed
Subcooling _____
Superheat _____

Entering Source Water _____ °F
Entering Water Pressure Drop _____ PSI
Leaving Source Water _____ °F
Leaving Water Pressure Drop _____ PSI

NOTE: Do not attach refrigerant gauges unless a problem is suspected!

Hot Water Cycle Analysis

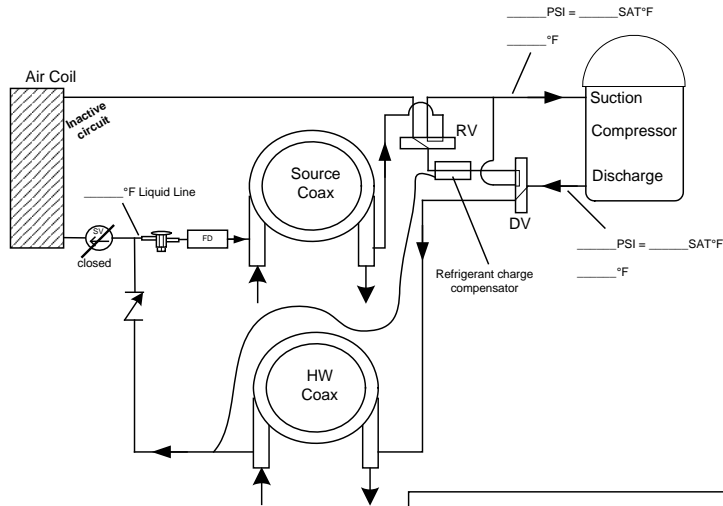

Unit Amp Draw _____
Line Voltage _____
Loop: _____ Open _____ Closed
Subcooling _____
Superheat _____

Entering Source Water _____ °F
Entering Water Pressure Drop _____ PSI
Leaving Source Water _____ °F
Leaving Water Pressure Drop _____ PSI
Entering Load Water _____ °F
Leaving Load Water _____ °F

NOTE: Do not attach refrigerant gauges unless a problem is suspected!

Preventative Maintenance

Water Coil Maintenance

1. Keep all air out of the water. An open loop system should be checked to ensure that the well head is not allowing air to infiltrate the water line. Lines should always be airtight.
2. Keep the system under pressure at all times. It is recommended in open loop systems that the water control valve be placed in the discharge line to prevent loss of pressure during off cycles. Closed loop systems must have positive static pressure.

NOTE: On open loop systems, if the installation is in an area with a known high mineral content (125 PPM or greater) in the water, it is best to establish with the owner a periodic maintenance schedule so the coil can be checked regularly. Should periodic coil cleaning be necessary, use standard coil cleaning procedures which are compatible with either the cupronickel or copper water lines. Generally, the more water flowing through the unit the less chance for scaling.

Other Maintenance

Filters

Filters must be clean to obtain maximum performance. They should be inspected monthly under normal operating conditions and be replaced when necessary. Units should never be operated without a filter.

Condensate Drain

In areas where airborne bacteria produce a slime in the drain pan, it may be necessary to treat chemically to minimize the problem. The condensate drain can pick up lint and dirt, especially with dirty filters. Inspect twice a year to avoid the possibility of overflow.

Blower Motors

ECM blower motors are equipped with sealed ball bearings and require no periodic oiling.

Hot Water Generator Coil

See Water Coil Maintenance section.

Air Coil

The air coil must be cleaned to obtain maximum performance. Check once a year under normal operating conditions and, if dirty, brush or vacuum (with a brush attachment) clean. Care must be taken not to damage the aluminum fins while cleaning.



CAUTION: Fin edges are sharp.

Replacement Procedures

Obtaining Parts

When ordering service or replacement parts, refer to the model number and serial number of the unit as stamped on the serial plate attached to the unit. If replacement parts are required, mention the date of installation of the unit and the date of failure, along with an explanation of the malfunctions and a description of the replacement parts required.

In-Warranty Material Return

Material may not be returned except by permission of authorized warranty personnel. Contact your local distributor for warranty return authorization and assistance.

Service Parts List

Parts		Synergy3D Dual Capacity Vertical Units			
		038	049	064	072
Compressor	Compressor (ZPSK5Es)	34P641-01	34P642-01	34P643-01	34P644-01
	Run Capacitor	16P002D20	16P002D18	16P002D31	
	Sound Jacket	92P504A16			
	Power Harness	11P781-01			
	Solenoid Harness	11P782-02			
Motor & Blower	Blower Assembly	54S564-01N		54S560-01N	
	ECM Motor	14S564-01		14S557-01	
	High Static Blower Assembly	54S560-01N		N/A	
	Blower Module Assembly	PMK574		PMK572	
	High Static Blower Module Assembly	PMK572		N/A	
	Blower & Housing	53P501B01			
	ECM Harness	11P792-01			
	ECM Power Harness	11P585B03			
Refrigeration Components HW Pump	Air Coil	61P706-41S	61P715-41S	61P725-41S	
	Source Coax copper	62P574-01	62P543-04		
	Load Coax copper	62P574-01	62P543-04		
	Source Coax cupronickel	62P574-02	62P543-03		
	TXV Part Number	33P619-06	33P619-07	33P619-08	33P619-09
	DanfossTXV model #	TR6 3 Ton 3/8"	TR6 4 Ton 1/2"	TR6 5 Ton 1/2"	TR6 6 Ton 1/2"
	Reversing Valve	33P503-05	33P526-05		
	Diverting Valve	33P503-05	33P526-05		
	Filter Drier	36P500B01	36P500B02		
	Refrigerant Charge Compensator	36P512-01			
	*Hot Water Generator	62P516-05	62P516-03		
	Check Valve	33P589B02	33P589B03		
	Solenoid Valve	33P575-01			
	Hyrdonic Load Pump	24P002A03			
Electrical	Contactator	13P004A03	13P004A03	13P004A03	13P004A03
	Transformer	15P501B01	15P501B01	15P501B01	15P501B01
	3 Pole Power Block	12P503-06	12P503-06	12P503-06	12P503-06
	2 Pole Screw Term. Block	12P500A01	12P500A01	12P500A01	12P500A01
	Status Light Board	17P503-02	17P503-02	17P503-02	17P503-02
	Harness-Status Light Board	11P783-01	11P783-01	11P783-01	11P783-01
	Wire Harness Low Voltage Comp Cabinet	11P792-02			
	Synergy Board	17P513-08			
Sensors & Safeties	Freeze Detection Thermistor	12P505B03	12P505B03	12P505B03	12P505B03
	HWL Thermistor	12P505-10	12P505-10	12P505-10	12P505-10
	High Pressure Switch	SKHPE600	SKHPE600	SKHPE600	SKHPE600
	Low Pressure Switch	SKLPE40	SKLPE40	SKLPE40	SKLPE40
Misc	Plastic Top Wave	99P515-01	99P515-02	99P515-03	
	Plastic Bottom Wave	99P527-03			
	High Pressure Switch	SKHPE600			
	Air Filter	59P509-08	59P509-07	59P509-06	

NOTES: Part numbers subject to change.

* Hot Water Generator option does not include an internal pump or HWG sensor (13P073B04). A DPK5 will need to be ordered separately for the pump kit.

Revision Guide

Pages:	Description:	Date:	By:
Misc.	Updated for Aluminum Coils, Wiring Schematics	15 May 2017	JM
26-29,42	Updated Wiring Schematic for Auxiliary Heat Changes, ETL Logo, Service Parts List	14 April 2015	MA
4, 9	Updated Nomenclature Hot Water Generation Option, updated Open Loop Solenoid Valve Connection Option Wiring Diagrams	30 Sept 2014	MA
All	Updated to new Revision, Reformatted Layout	27 Dec 2013	DS
All	Updated Nomenclature to Reflect new ECM Blower Motor	09 Nov 2012	DS
42	Updated Parts List	09 Nov 2012	DS
35	Updated Cooling Capacity Corrections	11 Oct 2012	DS
43	Added Revision Guide	11 Oct 2012	DS



Manufactured by
WaterFurnace International, Inc.
9000 Conservation Way
Fort Wayne, IN 46809
www.waterfurnace.com

Product: **Synergy3D**
Type: Geothermal Heat Pump with Water Heating
for Radiant Floor Applications
Size: 3-6 Ton Dual Capacity
Document: Installation Manual

