

Versatec 500

Commercial
Water Source/Geothermal Heat Pump

- R-410A Refrigerant
- 7-30 Tons

Installation Information

Water Piping Connections

Electrical

Startup Procedures

Troubleshooting

Preventive Maintenance



Versatec 500 WSHP 7-30 Ton Installation Manual



Table of Contents

Model Nomenclature	4
Electrical Availability	4
General Installation Information	5
Dimensional Data	6
Installation Notes	14
240-360 Economizer	17
Duct System, Water Piping	25
Condensate Drain	26
Water Quality	27
System Cleaning and Flushing	28
Open Loop Ground Water Systems	29
Freeze Detection	29
Electrical Connections	30
Electrical Data	31
Unit Weights	31
Blower Performance Data	32
Wiring Schematics	36
Controls - Aurora Controls	57
Unit Startup	66
Operating Limits	67
Operating Parameters	67
Pressure Drop	68
Reference Calculations and Legend	69
Refrigerant Circuit Guideline	70
Compressor and Thermistor Resistance	71
Troubleshooting	72
Startup/Troubleshooting Form	73
Preventive Maintenance	75
Replacement Procedures	75
Revision Guide	76

Model Nomenclature

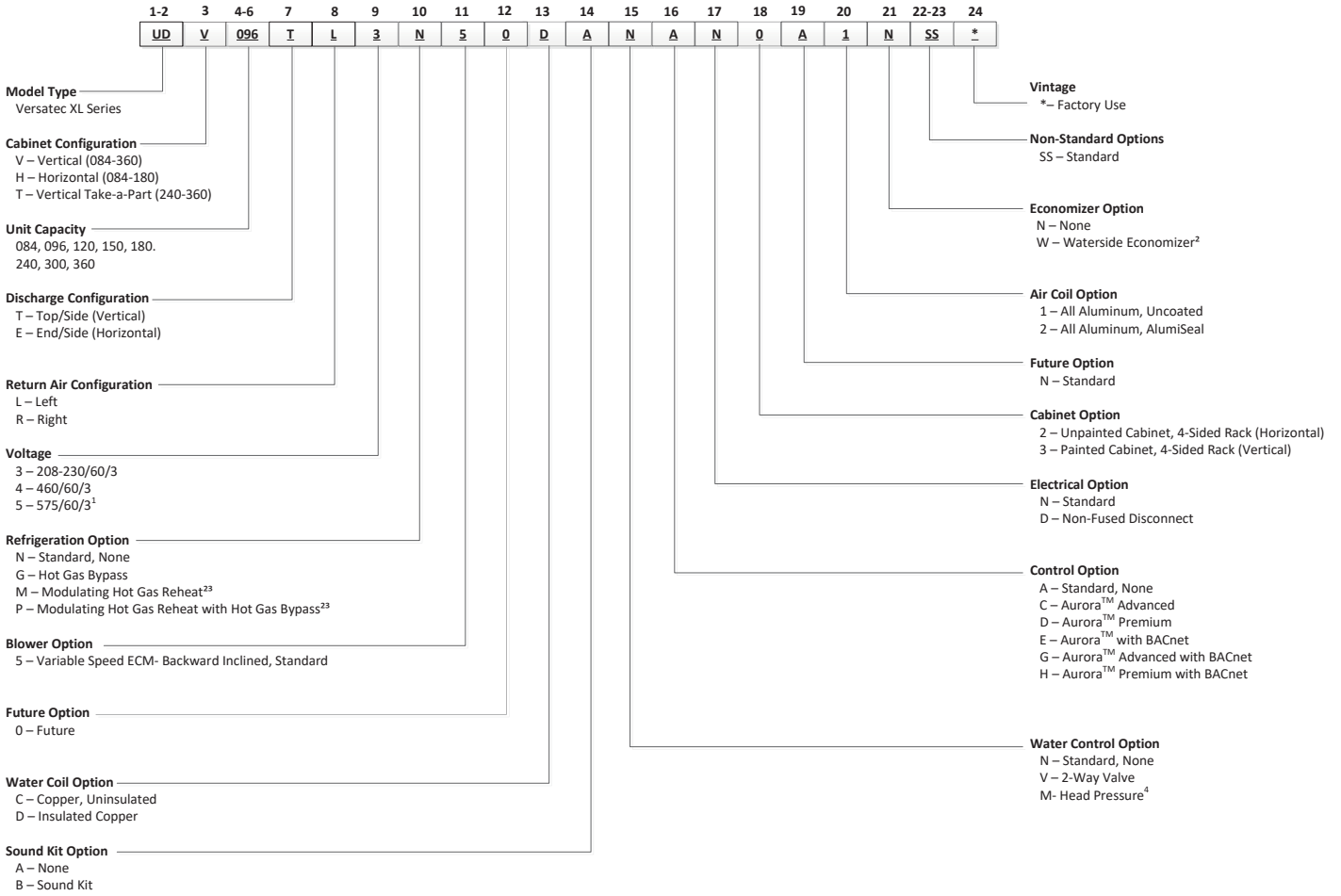

Note:
1- 575V option includes factory installed step down transformer on plenum fan.
2- Requires Advanced or Premium Controls.
3- Not available on UDH180
4- Head Pressure Control requires Premium Controls and Modulating Hot Gas Reheat.

Electrical Availability

Voltage	Dual Capacity Compressor		
	084	096	120
208-230/60/3	●	●	●
460/60/3	●	●	●
575/60/3	●	●	●

Voltage	Two Compressor				
	150	180	240	300	360
208-230/60/3	●	●	●	●	●
460/60/3	●	●	●	●	●
575/60/3	●	●	●	●	●

● - Available

3/30/21

General Installation Information

Safety Considerations



WARNING: Before performing service or maintenance operations on a system, turn off main power switches to the indoor unit. If applicable, turn off the accessory heater power switch. Electrical shock could cause personal injury.

Installing and servicing heating and air conditioning equipment can be hazardous due to system pressure and electrical components. Only trained and qualified service personnel should install, repair or service heating and air conditioning equipment. Untrained personnel can perform the basic maintenance functions of cleaning coils and cleaning and replacing filters. All other operations should be performed by trained service personnel. When working on heating and air conditioning equipment, observe precautions in the literature, tags and labels attached to the unit and other safety precautions that may apply.

Follow all safety codes. Wear safety glasses and work gloves. Use a quenching cloth for brazing operations and have a fire extinguisher available.

Moving and Storage

Move units in the normal “up” orientation. Horizontal units may be moved and stored per the information on the packaging. Do not stack more than three units in total height. When the equipment is received, all items should be carefully checked against the bill of lading to be sure all crates and cartons have been received. Examine units for shipping damage, removing the units from the packaging if necessary. Units in question should also be internally inspected. If any damage is noted, the carrier should make the proper notation on the delivery receipt, acknowledging the damage.

Unit Location

Locate the unit in an indoor area that allows for easy removal of the filter and access panels. Location should have enough space for service personnel to perform maintenance or repair. Provide sufficient room to make water, electrical and duct connection(s). If the unit is located in a confined space, such as a closet, provisions must be made for return air to freely enter the space by means of a louvered door, etc. Any access panel screws that would be difficult to remove after the unit is installed should be removed prior to setting the unit. On horizontal units, allow adequate room below the unit for a condensate drain trap and do not locate the unit above supply piping. Care should be taken when units are located in unconditioned spaces to prevent damage from frozen water lines and excessive heat that could damage electrical components.



WARNING: To avoid equipment damage and possible voiding of warranty, be sure that properly sized strainers are installed upstream of both brazed plate heat exchangers to protect them against particles in the fluid.

Installing Vertical Units

Prior to setting the unit in place, remove and discard the compressor hold down shipping bolt located at the front of the compressor mounting bracket.

Vertical units are available in left or right air return configurations. Top flow vertical units should be mounted level on a vibration absorbing pad slightly larger than the base to provide isolation between the unit and the floor. It is not necessary to anchor the unit to the floor.

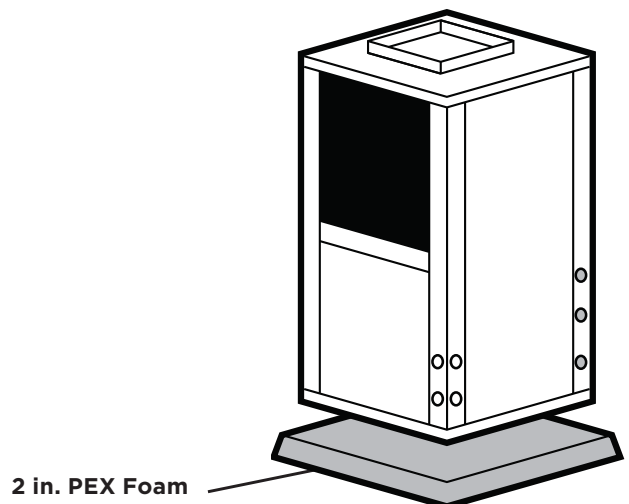

Dimensional Data

LEFT RETURN
SHOWN

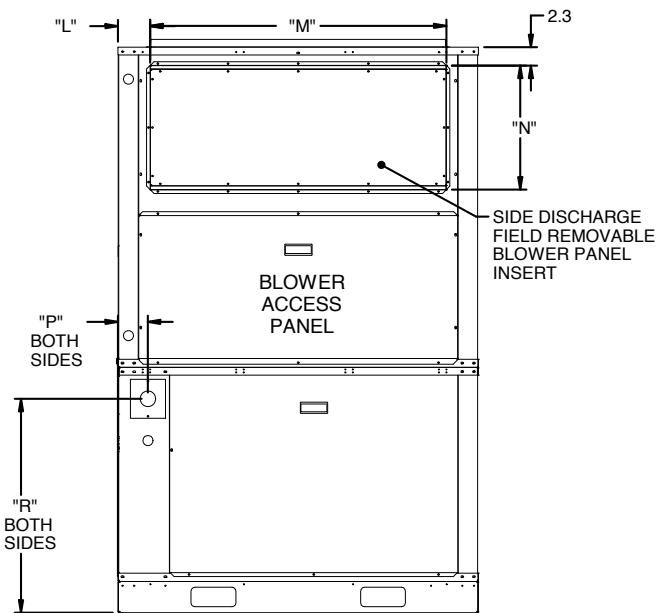
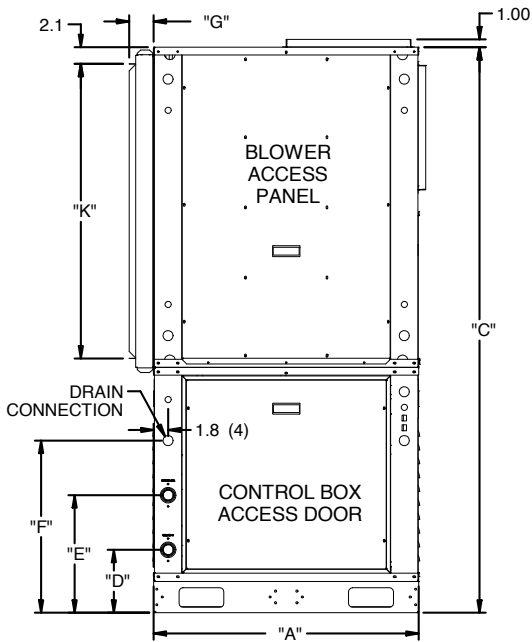
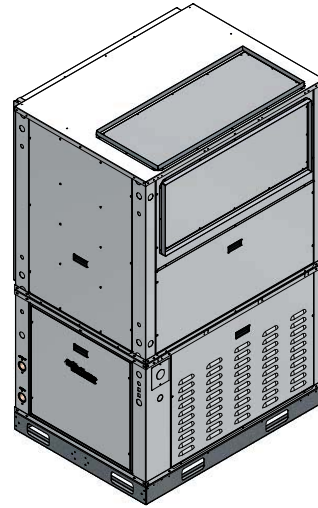
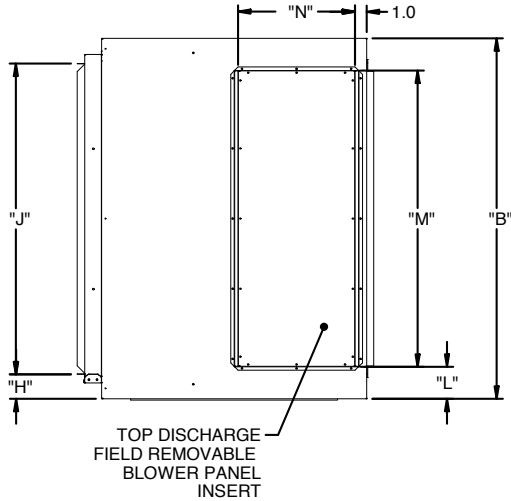

Vertical Dimensional Data

Vertical Models	Overall Cabinet			Water Connections				Return Connection*				Discharge Connection			Electrical Connections		
	A	B	C	1	2	3	Loop	using deluxe filter rack				L	M	N	P	R	
	Width	Depth	Height	In	Out	Condensate	Water FPT	Filter Rack	From Edge	Return Depth	Return Height	From Edge	Supply Width	Supply Height	From Edge	Height	
084-096	in.	34.0	36.3	72.5	8.1	15.1	22.1	1 1/4"	3.1	3.2	29.9	37.8	4.1	28.0	16.0	3.9	27.4
	cm.	86.4	92.2	184.2	20.6	38.4	56.1	31.8 mm	7.9	8.1	75.9	96.0	10.4	71.1	40.6	9.9	69.6
120	in.	34.0	36.3	72.5	8.1	15.1	22.1	2"	3.1	3.2	29.9	37.8	4.1	28.0	16.0	3.9	27.4
	cm.	86.4	92.2	184.2	20.6	38.4	56.1	50.8 mm	7.9	8.1	75.9	96.0	10.4	71.1	40.6	9.9	69.6
150-180	in.	34.0	46.3	72.5	8.1	15.1	22.1	2"	3.1	2.2	39.9	37.8	4.1	38.0	16.0	3.9	27.4
	cm.	86.4	117.5	184.2	20.6	38.4	56.1	50.8 mm	7.9	5.6	101.3	96.0	10.4	96.5	40.6	9.9	69.6

*Dimensions for return connections are for the deluxe filter rack that is suitable for ducted return applications

Dimensional Data cont.

LEFT RETURN SHOWN

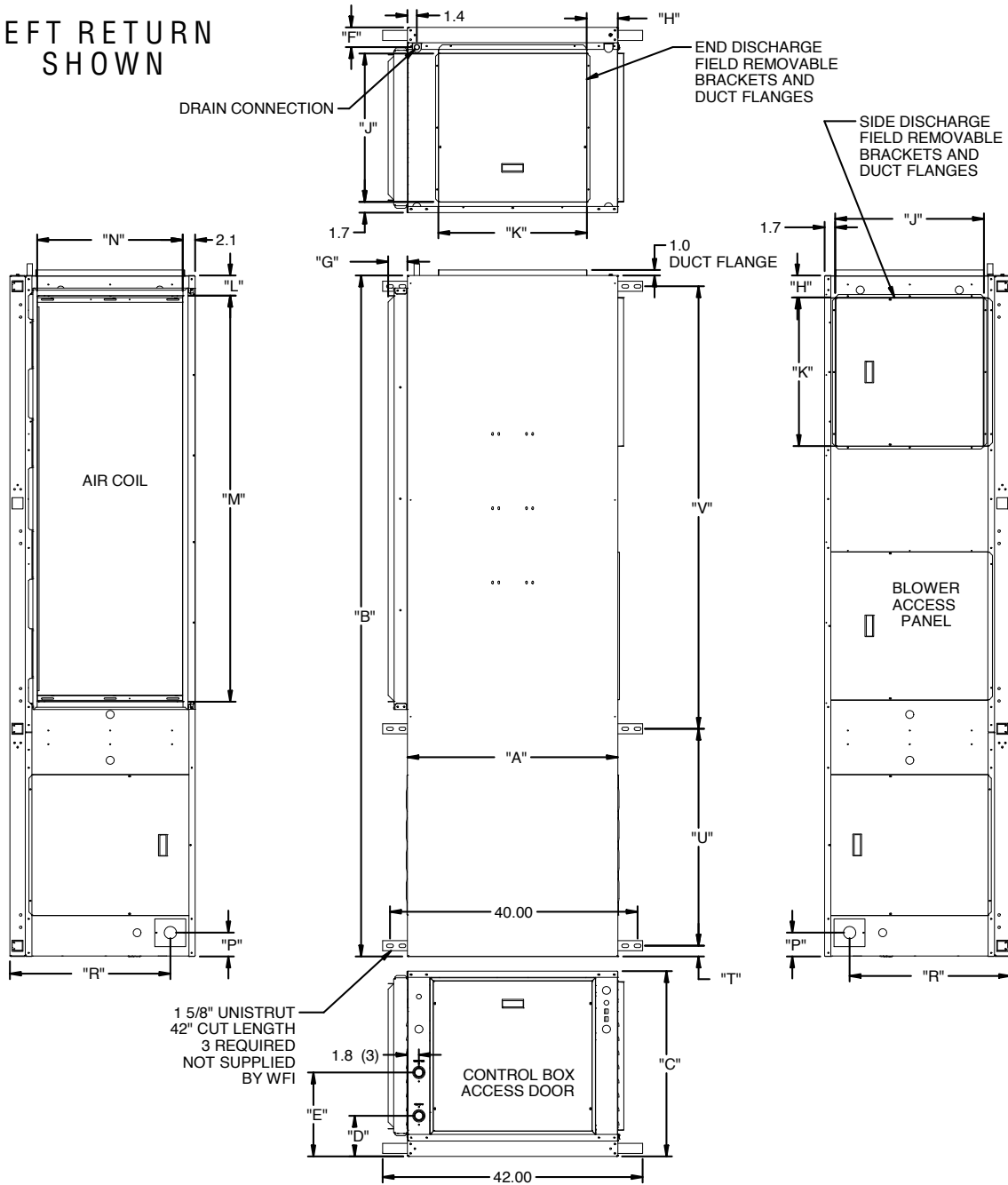

Horizontal Dimensional Data

Horizontal Models	Overall Cabinet			Water Connections				Discharge Connection			Return Connection*			Electrical Connections		Unistrut Hanging				
	A	B	C	1	2	5	Loop	G	H	J	K	L	M	N	P	R	T	U	V	
	Width	Depth	Height	In	Out	Condensate	Water FPT	Filter Rack Width	From Edge	Supply Height	Supply Width	From Edge	Return Depth	Return Height	From Edge	Height	From Edge	Unistrut Unistrut	Unistrut Unistrut	
084-096	in.	34.0	89.0	29.9	8.1	15.1	3.2	1 1/4"	3.1	5.0	24.0	24.0	4.3	47.6	23.5	3.9	25.9	1.7	24.6	61.0
	cm.	86.4	226.1	75.9	20.6	38.4	8.1	31.8 mm	7.9	12.7	61.0	61.0	10.9	120.9	59.7	9.9	65.8	4.3	62.5	154.9
120	in.	34.0	89.0	29.9	8.1	15.1	3.2	2"	3.1	5.0	24.0	24.0	4.3	47.6	23.5	3.9	25.9	1.7	24.6	61.0
	cm.	86.4	226.1	75.9	20.6	38.4	8.1	50.8 mm	7.9	12.7	61.0	61.0	10.9	120.9	59.7	9.9	65.8	4.3	62.5	154.9
150-180	in.	34.0	110.0	29.9	8.1	15.1	3.2	2"	3.1	5.0	24.0	24.0	4.3	65.6	23.5	3.9	25.9	1.7	35.1	71.5
	cm.	86.4	279.4	75.9	20.6	38.4	8.1	50.8 mm	7.9	12.7	61.0	61.0	10.9	166.6	59.7	9.8	65.8	4.3	89.2	181.6

*Dimensions for return connections are for the deluxe filter rack that is suitable for ducted return applications

Dimensional Data cont.

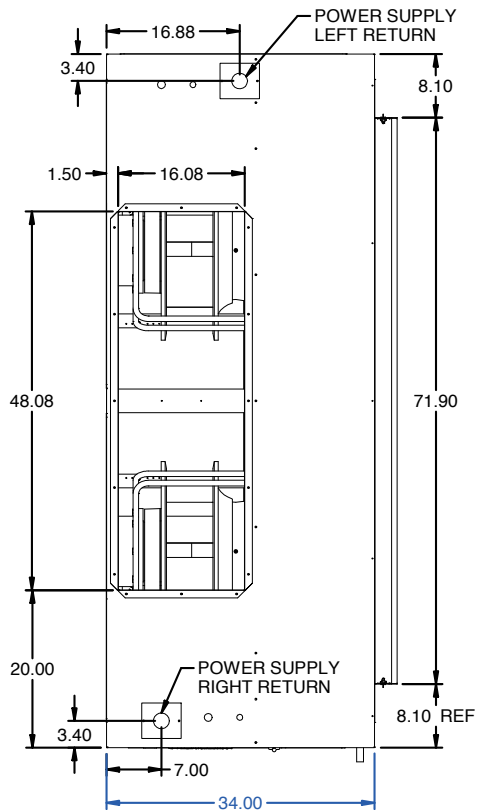

240-360
RIGHT RETURN
SHOWN

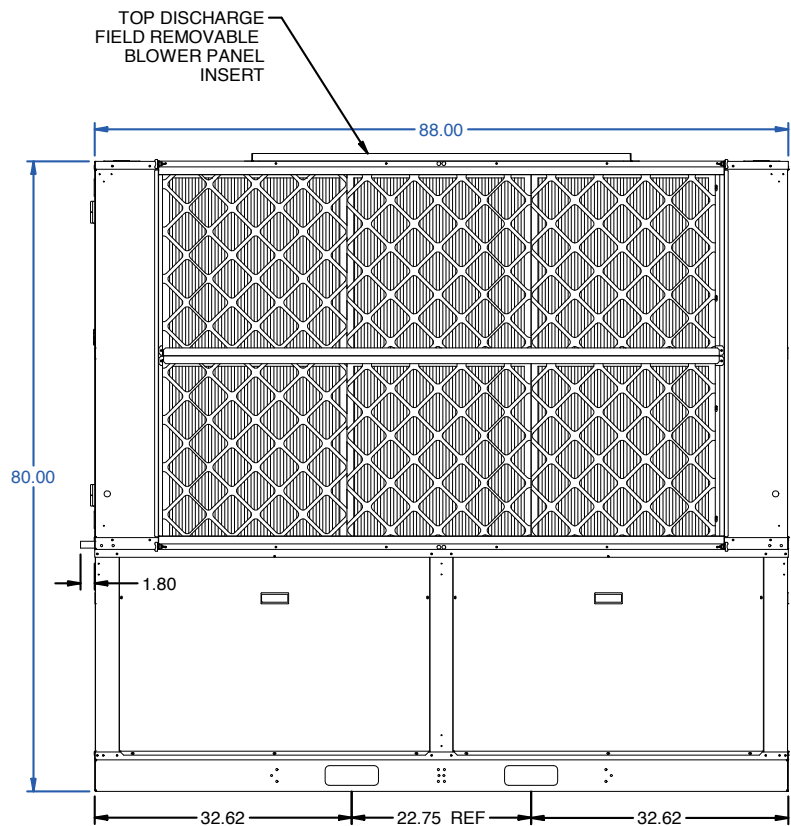
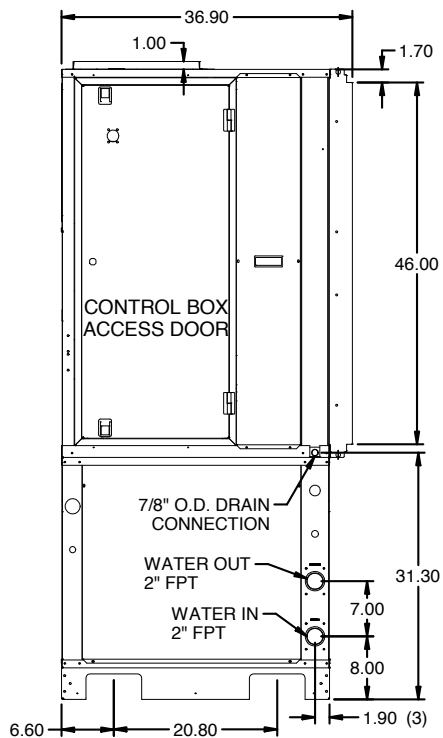
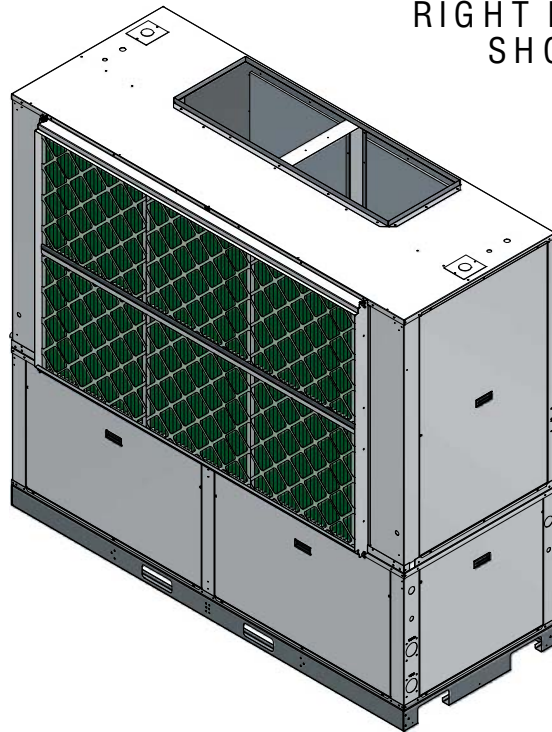

Dimensional Data cont.

084-180 TOP FLOW ECONOMIZER OPTION LR

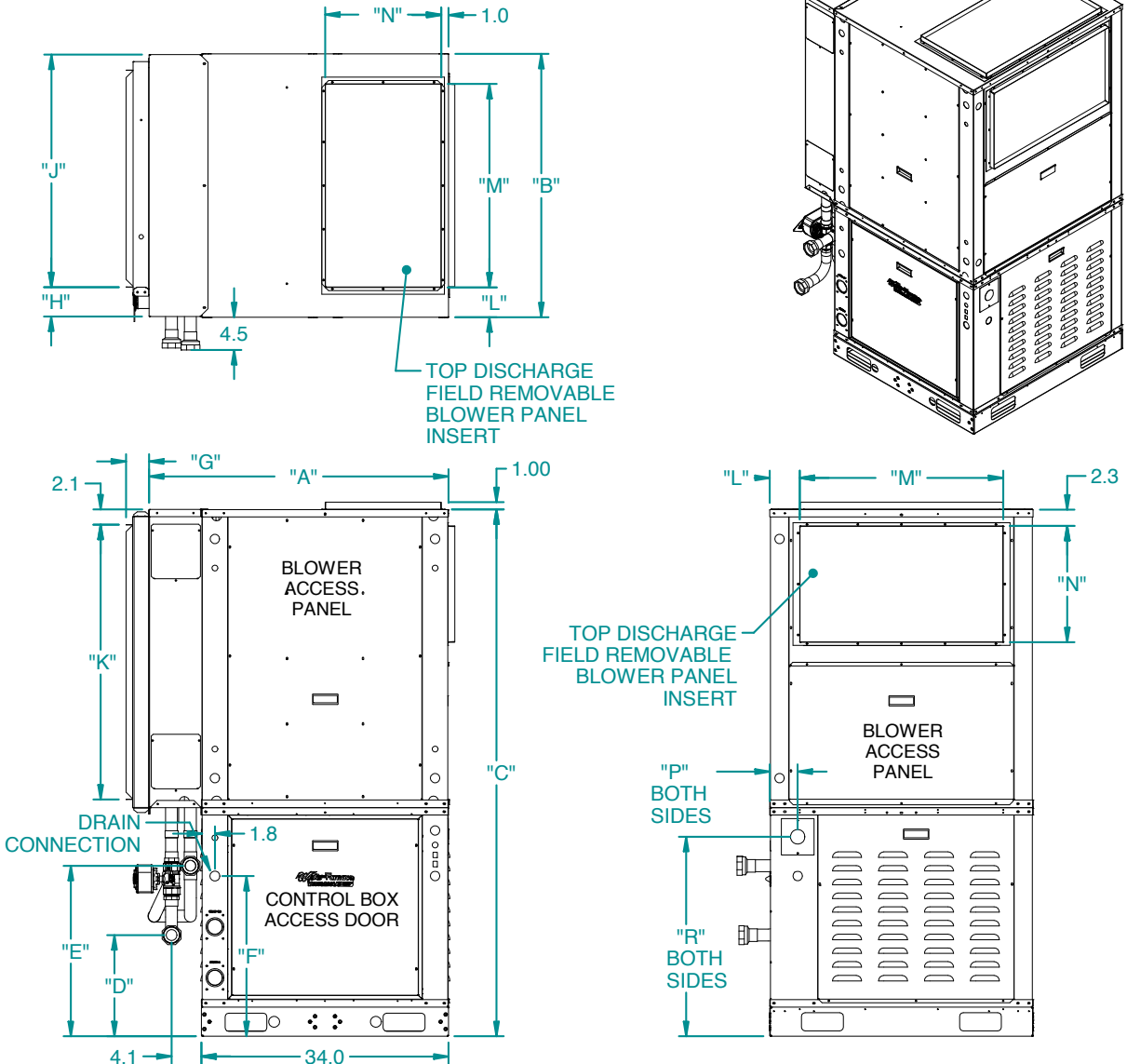

Vertical Dimensional Data

Vertical Models	Overall Cabinet			Water Connections				Return Connection*				Discharge Connection			Electrical Connections		
	A	B	C	1	2	3	Loop	using deluxe filter rack				L	M	N	P	R	
	Width	Depth	Height	In	Out	Condensate		Filter Rack	From Edge	Return Depth	Return Height	From Edge	Supply Width	Supply Height	From Edge	Height	
084-096	in.	41.2	36.3	72.5	13.9	23.5	22.1	1 1/4"	3.1	3.2	29.9	37.8	4.1	28.0	16.0	3.9	27.4
	cm.	104.6	92.2	184.2	35.3	59.7	56.1	31.8 mm	7.9	8.1	75.9	96.0	10.4	71.1	40.6	9.9	69.6
120	in.	41.2	36.3	72.5	13.9	23.5	22.1	2"	3.1	3.2	29.9	37.8	4.1	28.0	16.0	3.9	27.4
	cm.	104.6	92.2	184.2	35.3	59.7	56.1	50.8 mm	7.9	8.1	75.9	96.0	10.4	71.1	40.6	9.9	69.6
150-180	in.	41.2	46.3	72.5	14.7	24.2	22.1	2"	3.1	2.2	39.9	37.8	4.1	38.0	16.0	3.9	27.4
	cm.	104.6	117.5	184.2	37.3	61.5	56.1	50.8 mm	7.9	5.6	101.3	96.0	10.4	96.5	40.6	9.9	69.6

Dimensional Data cont.

084-180 TOP FLOW ECONOMIZER OPTION RR

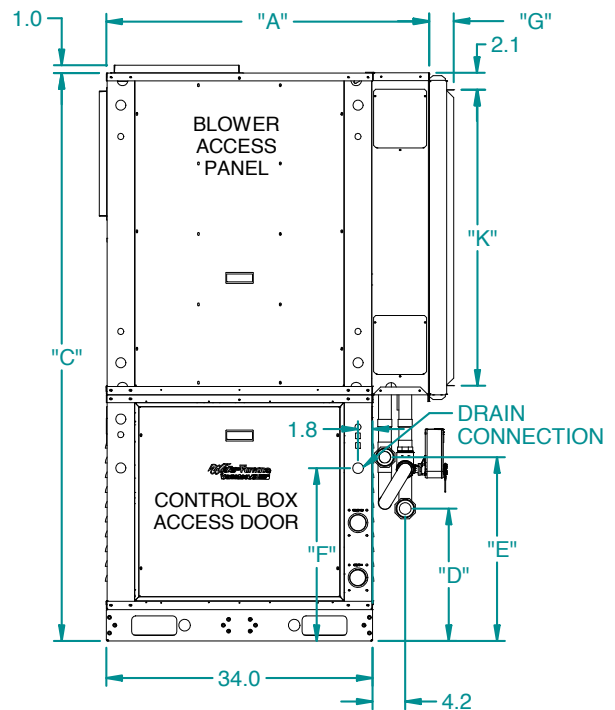
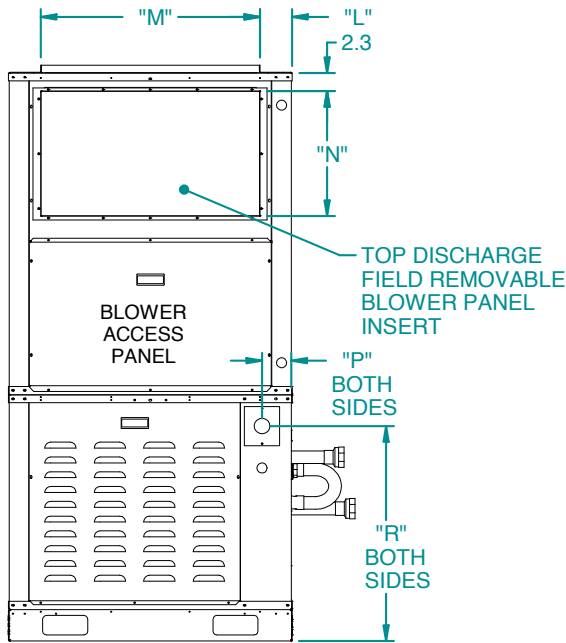
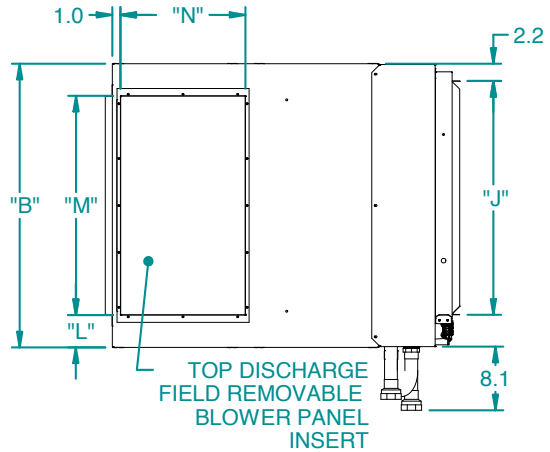
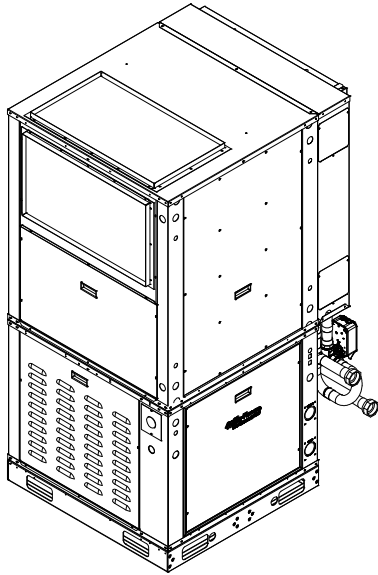

Vertical Dimensional Data

Vertical Models	Overall Cabinet			Water Connections				Return Connection*				Discharge Connection			Electrical Connections		
	A	B	C	1	2	3	Loop	using deluxe filter rack				L	M	N	P	R	
	Width	Depth	Height	In	Out	Condensate		Water FPT	Filter Rack	From Edge	Return Depth	Return Height	From Edge	Supply Width	Supply Height	From Edge	Height
084-096	in.	41.2	36.3	72.5	16.9	23.5	22.1	1 1/4"	3.1	3.2	29.9	37.8	4.1	28.0	16.0	3.9	27.4
	cm.	104.6	92.2	184.2	42.9	59.7	56.1	31.8 mm	7.9	8.1	75.9	96.0	10.4	71.1	40.6	9.9	69.6
120	in.	41.2	36.3	72.5	16.9	23.5	22.1	2"	3.1	3.2	29.9	37.8	4.1	28.0	16.0	3.9	27.4
	cm.	104.6	92.2	184.2	42.9	59.7	56.1	50.8 mm	7.9	8.1	75.9	96.0	10.4	71.1	40.6	9.9	69.6
150-180	in.	41.2	46.3	72.5	17.7	24.2	22.1	2"	3.1	2.2	39.9	37.8	4.1	38.0	16.0	3.9	27.4
	cm.	104.6	117.5	184.2	45.0	61.5	56.1	50.8 mm	7.9	5.6	101.3	96.0	10.4	96.5	40.6	9.9	69.6

Dimensional Data cont.

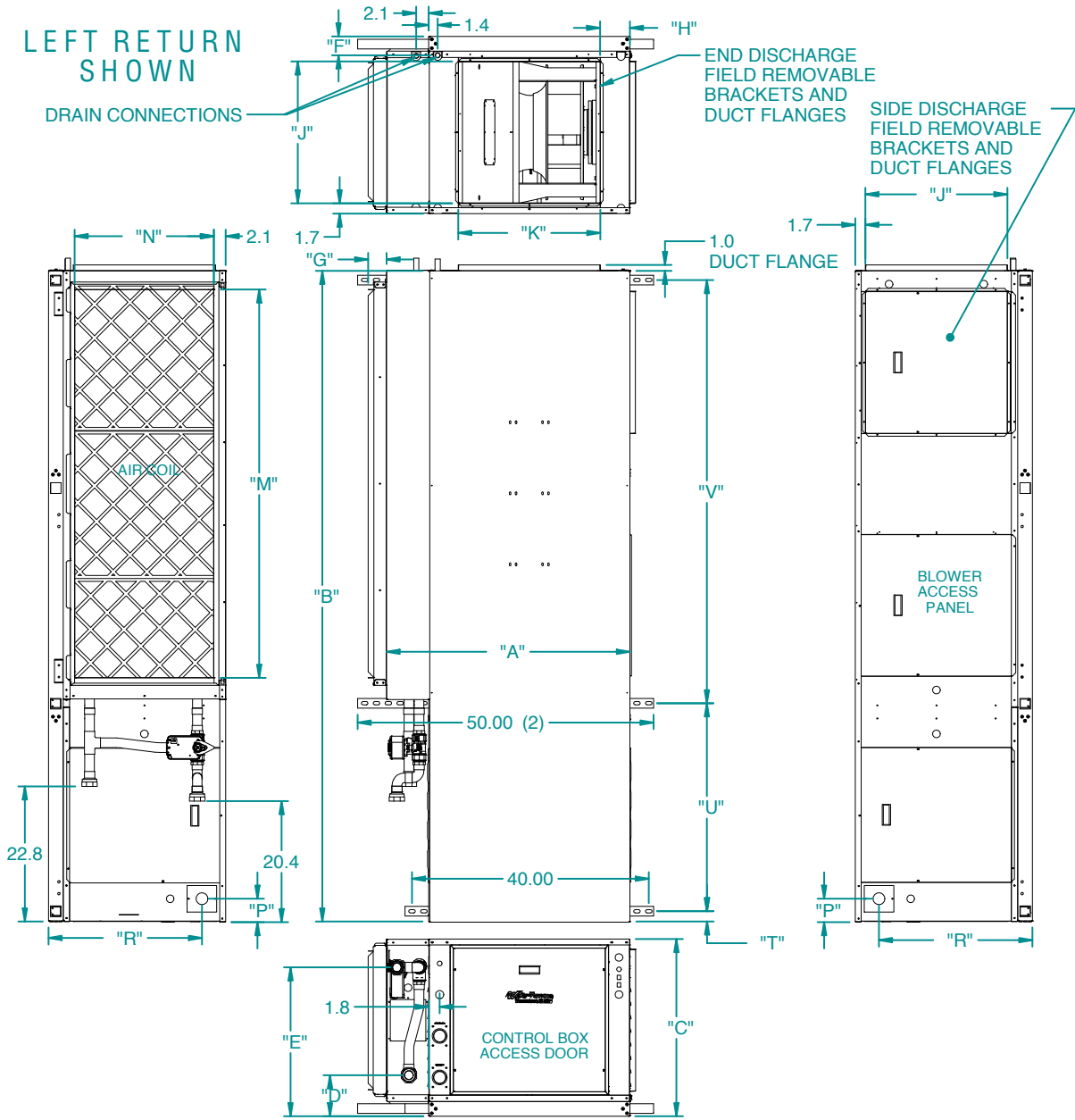

Horizontal Dimensional Data

Horizontal Models	Overall Cabinet			Water Connections					Discharge Connection				Return Connection*			Electrical Connections		Unistrut Hanging		
	A	B	C	1	2	5		G	H	J	K	L	M	N	P	R	T	U	V	
	Width	Depth	Height	In	Out	Cond-ensate	Loop	Filter Rack	From Edge	Supply Height	Supply Width	From Edge	Return Depth	Return Height	From Edge	Height	From Edge	Unistrut/Unistrut	Unistrut/Unistrut	
	in.	cm.	in.	cm.	in.	cm.	in.	mm	in.	mm	in.	mm	in.	mm	in.	mm	in.	mm	in.	mm
084-096	41.1	89.0	29.9	6.9	25.1	3.2	1 1/4"	3.1	5.0	24.0	24.0	4.3	47.6	23.5	3.9	25.9	1.7	24.6	61.0	
	104.4	226.1	75.9	17.5	63.8	8.1	31.8 mm	7.9	12.7	61.0	61.0	10.9	120.9	59.7	9.9	65.8	4.3	62.5	154.9	
120	41.1	89.0	29.9	6.9	25.1	3.2	2"	3.1	5.0	24.0	24.0	4.3	47.6	23.5	3.9	25.9	1.7	24.6	61.0	
	104.4	226.1	75.9	17.5	63.8	8.1	50.8 mm	7.9	12.7	61.0	61.0	10.9	120.9	59.7	9.9	65.8	4.3	62.5	154.9	
150-180	41.1	110.0	29.9	6.9	25.1	3.2	2"	3.1	5.0	24.0	24.0	4.3	65.6	23.5	3.9	25.9	1.7	35.1	71.5	
	104.4	279.4	75.9	17.5	63.8	8.1	50.8 mm	7.9	12.7	61.0	61.0	10.9	166.6	59.7	9.8	65.8	4.3	89.2	181.6	

*Dimensions for return connections are for the deluxe filter rack that is suitable for ducted return applications

Dimensional Data cont.

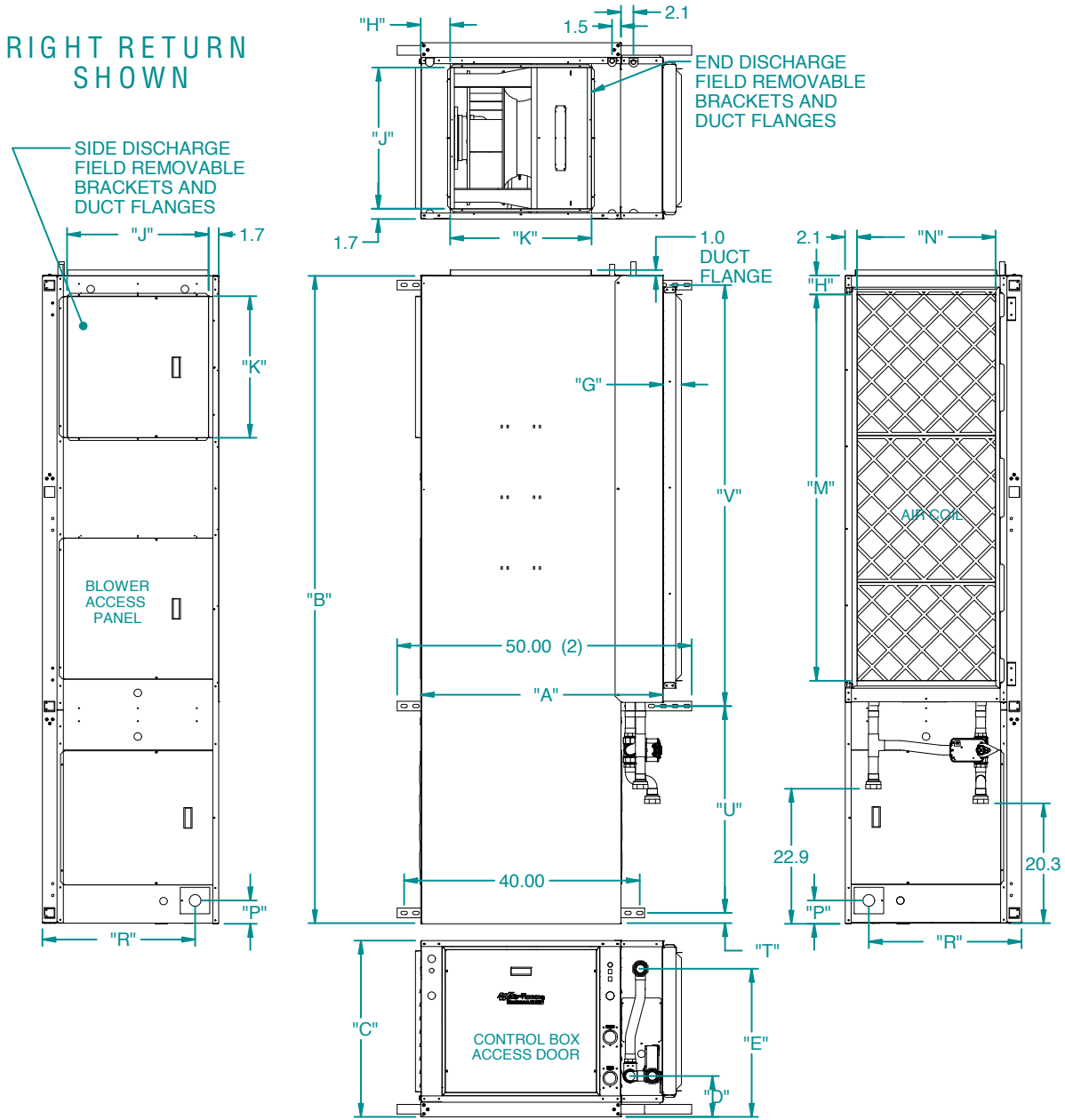

Horizontal Dimensional Data

Horizontal Models	Overall Cabinet			Water Connections				Discharge Connection				Return Connection*			Electrical Connections		Unistrut Hanging			
	A	B	C	1	2	5	Loop	G	H	J	K	L	M	N	P	R	T	U	V	
	Width	Depth	Height	In	Out	Condensate	Water FPT	Filter Rack Width	From Edge	Supply Height	Supply Width	From Edge	Return Depth	Return Height	From Edge	Height	From Edge	Unistrut	Unistrut	
084-096	in.	41.1	89.0	29.9	6.9	25.1	3.2	1 1/4"	3.1	5.0	24.0	24.0	4.3	47.6	23.5	3.9	25.9	1.7	24.6	61.0
	cm.	104.4	226.1	75.9	17.5	63.8	8.1	31.8 mm	7.9	12.7	61.0	61.0	10.9	120.9	59.7	9.9	65.8	4.3	62.5	154.9
120	in.	41.1	89.0	29.9	6.9	25.1	3.2	2"	3.1	5.0	24.0	24.0	4.3	47.6	23.5	3.9	25.9	1.7	24.6	61.0
	cm.	104.4	226.1	75.9	17.5	63.8	8.1	50.8 mm	7.9	12.7	61.0	61.0	10.9	120.9	59.7	9.9	65.8	4.3	62.5	154.9
150-180	in.	41.1	110.0	29.9	6.9	25.1	3.2	2"	3.1	5.0	24.0	24.0	4.3	65.6	23.5	3.9	25.9	1.7	35.1	71.5
	cm.	104.4	279.4	75.9	17.5	63.8	8.1	50.8 mm	7.9	12.7	61.0	61.0	10.9	166.6	59.7	9.8	65.8	4.3	89.2	181.6

*Dimensions for return connections are for the deluxe filter rack that is suitable for ducted return applications

Dimensional Data cont.

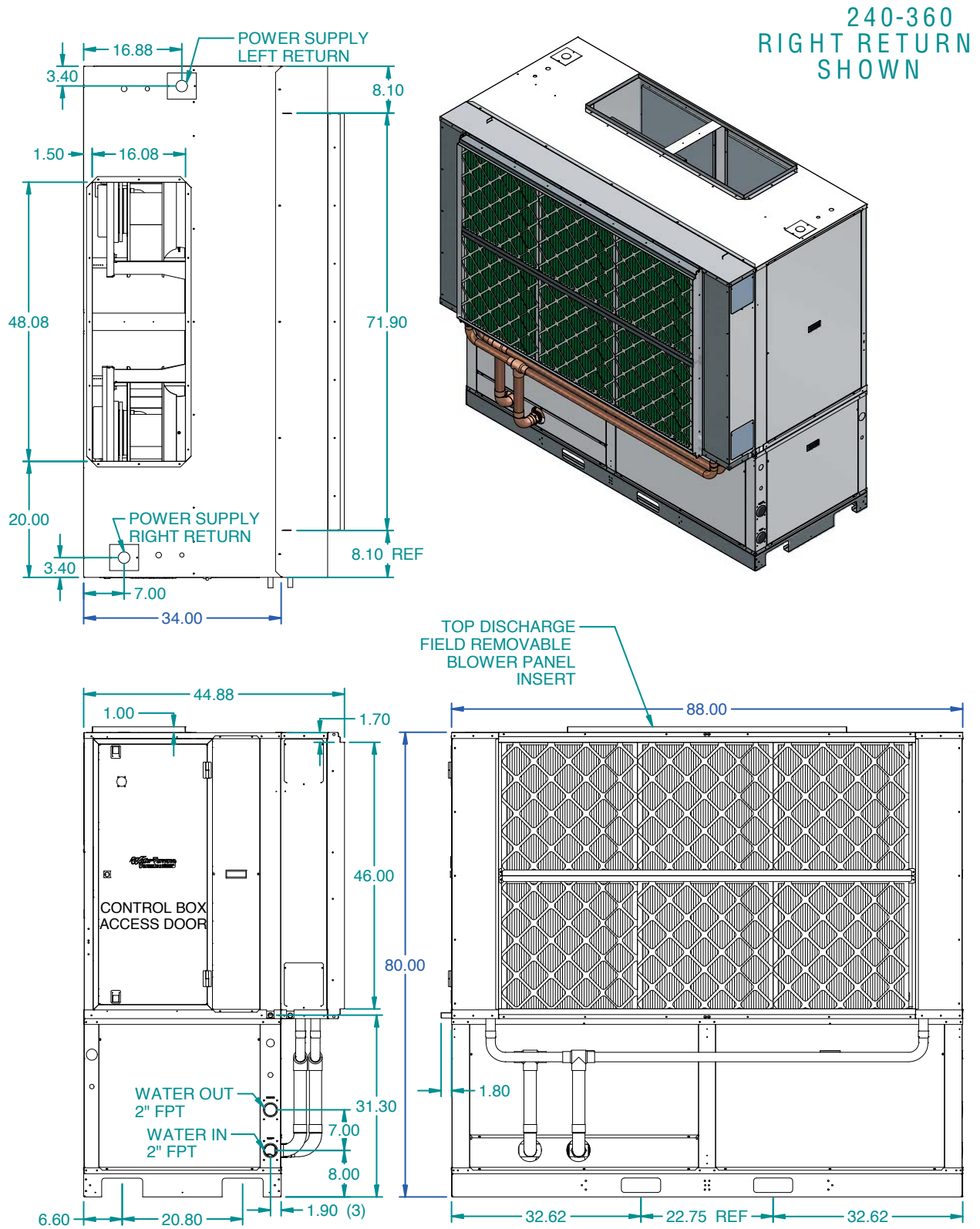

Installation Notes

Typical Unit Installation

Unit Location

Locate the unit in an indoor area that allows for easy removal of the filter and access panels. Location should have enough space for service personnel to perform maintenance or repair. Provide sufficient room to make water, electrical and duct connection(s). If the unit is located in a confined space, such as a closet, provisions must be made for return air to freely enter the space by means of a louvered door, etc. Any access panel screws that would be difficult to remove after the unit is installed should be removed prior to setting the unit. On horizontal units, allow adequate room below the unit for a condensate drain trap and do not locate the unit above supply piping. Care should be taken when units are located in unconditioned spaces to prevent damage from frozen water lines and excessive heat that could damage electrical components.

Water Piping

Piping is usually design as 'reverse return' to equalize flow paths through each unit. A short flexible pressure rated hose is used to make connection to the fixed building

piping system. This hose is typically stainless steel braid and includes a swivel fitting on one end for easy removal and is flexible to help isolate the unit for quieter operation. Isolation valves for servicing, y-strainers for filtering and memory-stop flow valve or a balancing valve can be provided for consistent water flow through the unit.

All unit source water connections are fittings that accept a male pipe thread (MPT). Insert the connectors by hand, then tighten the fitting with a wrench to provide a leakproof joint. The open and closed loop piping system should include pressure/temperature ports for serviceability. The proper water flow must be provided to each unit whenever the unit operates. To assure proper flow, use pressure/temperature ports to determine the flow rate. These ports should be located at the supply and return water connections on the unit. The proper flow rate cannot be accurately set without measuring the water pressure drop through the refrigerant-to-water heat exchanger. Never use flexible hoses smaller than the inside diameter of the water connection at the unit. Limit hose length to 10 feet per connection. Check carefully for water leaks.

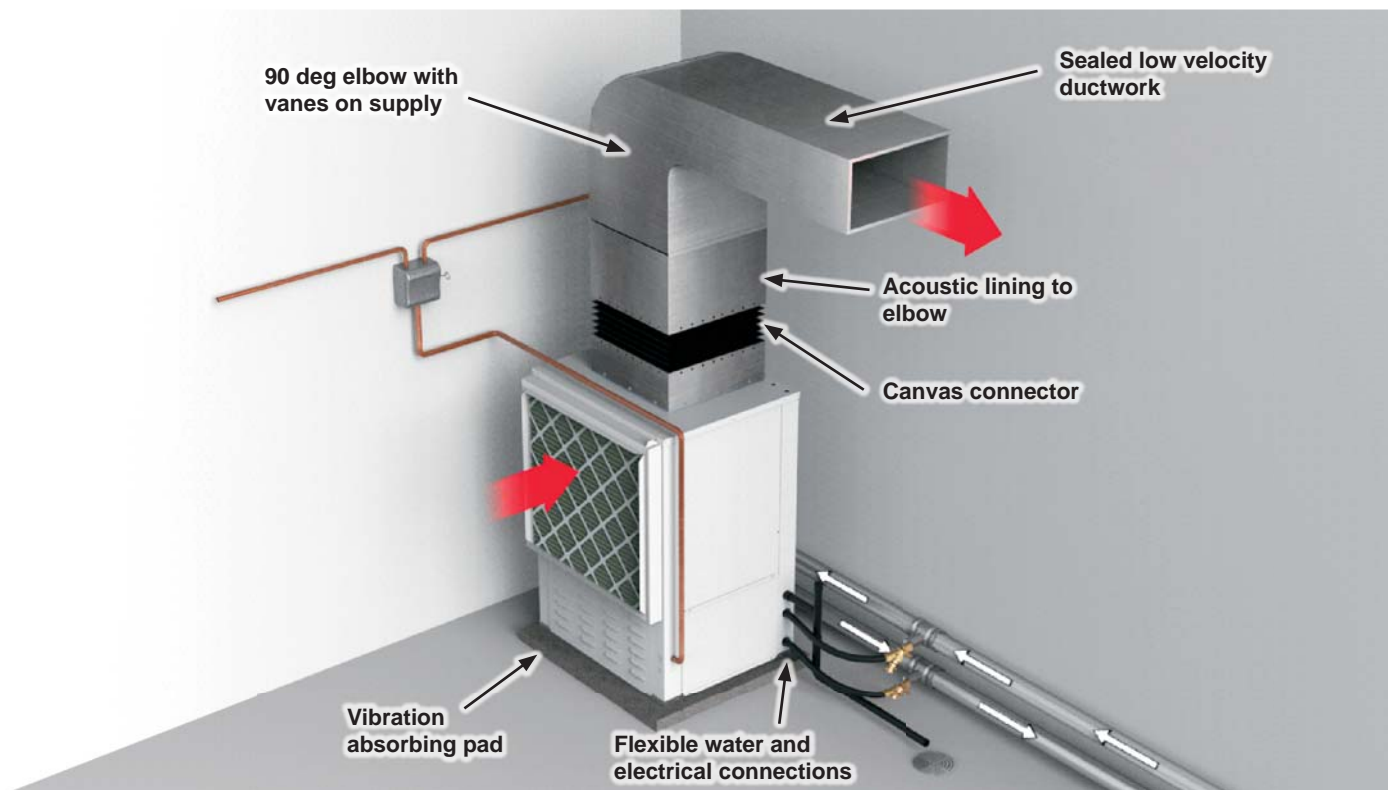

Installation Notes cont.

Installing Horizontal Units

Remove and discard the compressor hold down shipping bolt located at the front of the compressor mounting bracket prior to setting the unit in place. Horizontal units are available with side or end discharge.

NOTE: Left (Right) Return Side Discharge can be converted to Left (Right) Return End Discharge or vice versa, without additional custom sheet metal parts. Horizontal units are normally suspended from a ceiling by six 1/2 in. diameter threaded rods. The rods are usually attached to the unit by hanger bracket kits furnished with each unit.

Lay out and install the threaded rods and 1 5/8" strut channel as shown in the Horizontal Dimensional Data. The unit should be pitched approximately 1/4 in. toward the drain in both directions to facilitate the removal of condensate.

Some applications require the installation of horizontal units on an attic floor. In this case, the unit should be set in a full size secondary drain pan on top of a vibration absorbing pad. The secondary drain pan prevents possible condensate overflow or water leakage damage to the ceiling. The secondary drain pan is usually placed on a plywood base isolated from the ceiling joists by additional layers of vibration absorbing material.



CAUTION: Do not use rods smaller than 1/2 in. diameter since they may not be strong enough to support the unit. The rods must be securely anchored to the ceiling.

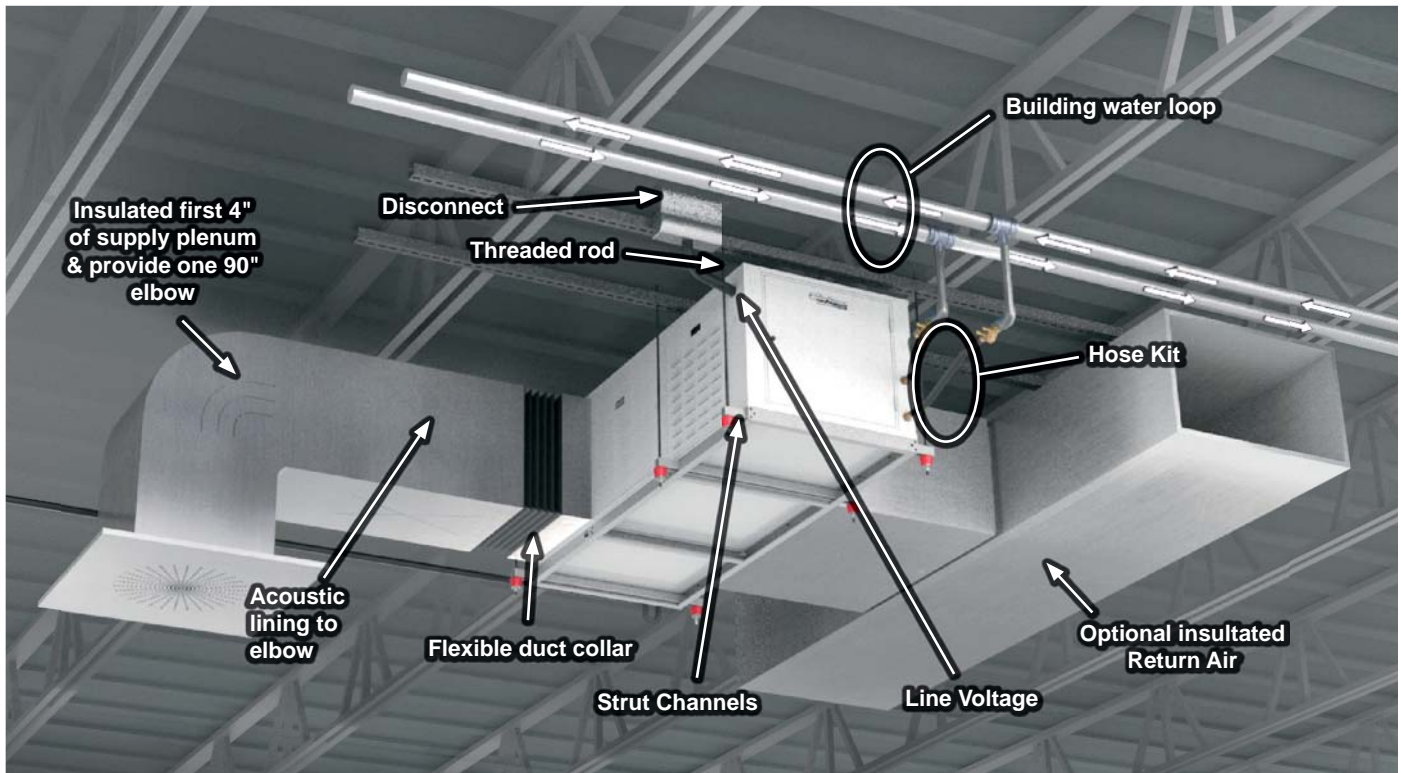

Installation Notes cont.

Acoustical Considerations and Equipment Sound Performance

Sound Performance

The unit is third party sound rated in accordance with ARI 260. Please consult the manufacture'sr Sound Performance Data Catalog for details on the AHRI standard and sound performance data.

Recommendations for Noise Reduction

Horizontal Unit Location

- Specify equipment with quietest sound power ratings
- Do not locate units above areas with a required NC 40 or less
- Space WSHP at least 10 ft (3m) apart to avoid noise summing of multiple units in a space.
- Maximize the height of the unit above the ceiling (horizontal).
- Suspend unit with isolation grommets that are appropriately rated to reduce vibrations (horizontal).

Vertical Unit Location

- Specify equipment with quietest sound power ratings
- Space WSHP at least 10 ft (3m) apart to avoid noise summing of multiple units in a space.
- Acoustic ceiling coatings can greatly reduce noise levels in mechanical rooms.
- Mount unit on a sound absorbing pad, extruded polystyrene, rubber or cork pad.

Ductwork

- Ensure return air grilles will not allow line of site noise to transfer to adjacent space. Use a sound barrier or some other material to isolate the grille from the unit. A supply grille, boot and short piece of flex duct pointed away from the unit can greatly attenuate equipment noise.
- Use a canvas isolation duct connector at the supply and return duct connection of the unit.
- Internally line the discharge and return duct within the first 4-8 feet of unit with acoustic insulation. Install an internally lined 'L' shaped return duct elbow at return grille. Face the elbow away from adjacent units.
- Always install at least one 90° elbow in the discharge duct to eliminate line of sight noise transmission of the blower.
- Use turning vanes at all elbows and tees to reduce turbulence.
- Limit supply duct velocities to less than 1,000 fpm
- Design and install ductwork as stiff as possible
- Allow 3 duct diameters both up and down stream of the unit before any fittings or transitions are installed.
- Use duct sealant on all duct joints.
- Install a short (2-4') of flex duct on all branch ducts just prior to discharge boot or diffuser to reduce vibration and duct sound prior to delivery in the room.
- Locate the branch duct balancing damper as far away from the diffuser as possible.
- In ceiling plenum systems, install an internally lined 'L' shaped return duct elbow at unit. Face the elbow away from adjacent units (horizontal).

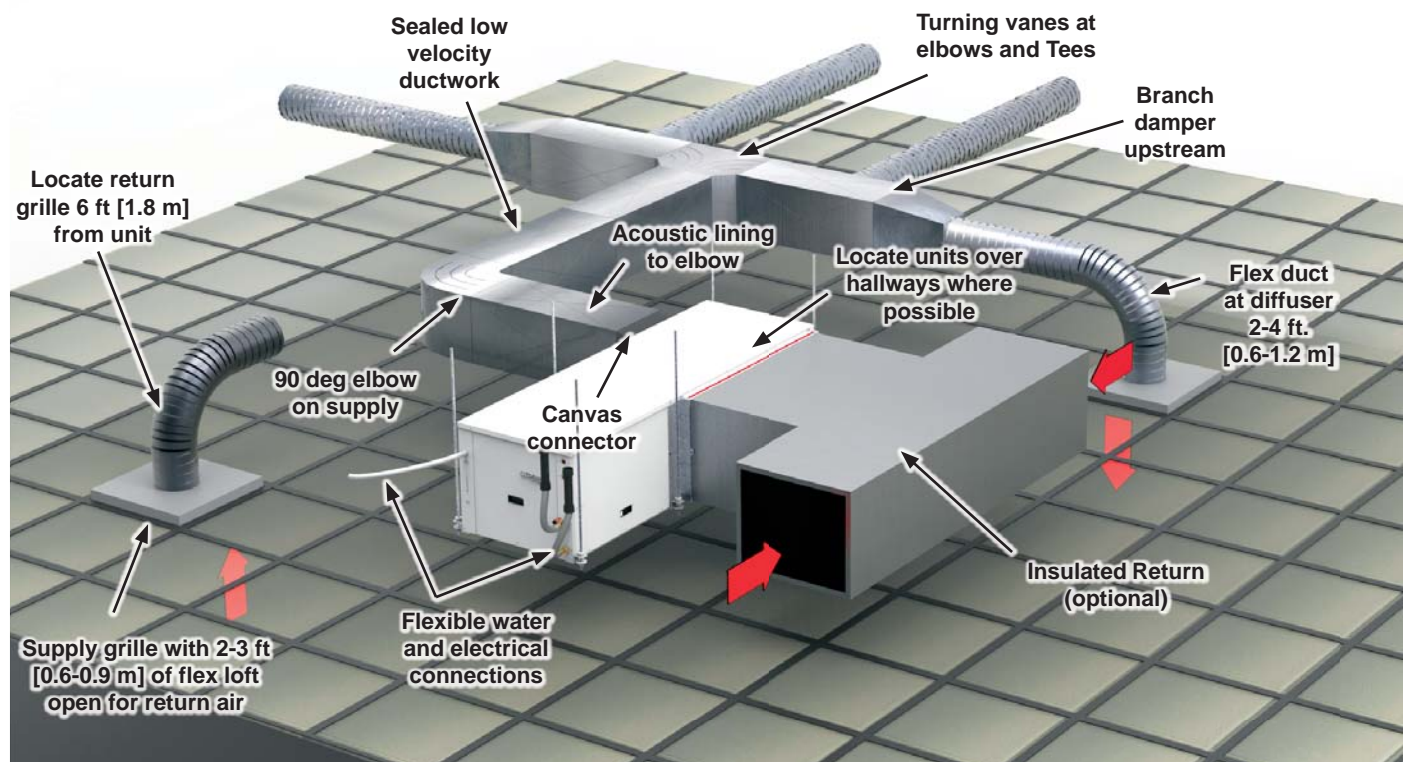

240-360 Economizer

1. Skip to step 8 if no economizer option.
2. Remove economizer access panel to remove overflow sensor switch terminal in drain pan.
3. Reattach economizer access panel.

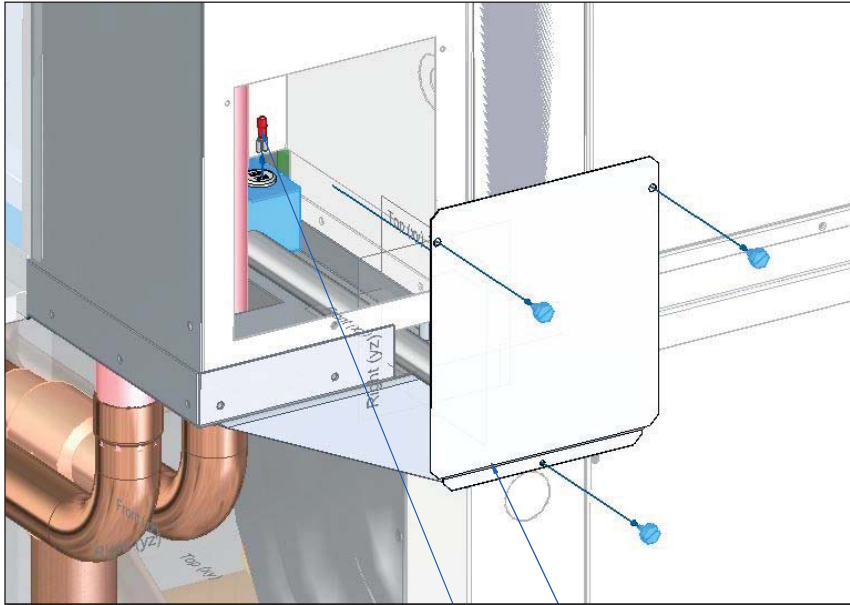

ECONOMIZER ACCESS PANEL
ECONOMIZER OVERFLOW DRAIN SWITCH TERMINAL



4. Remove (5) screws from top panel.

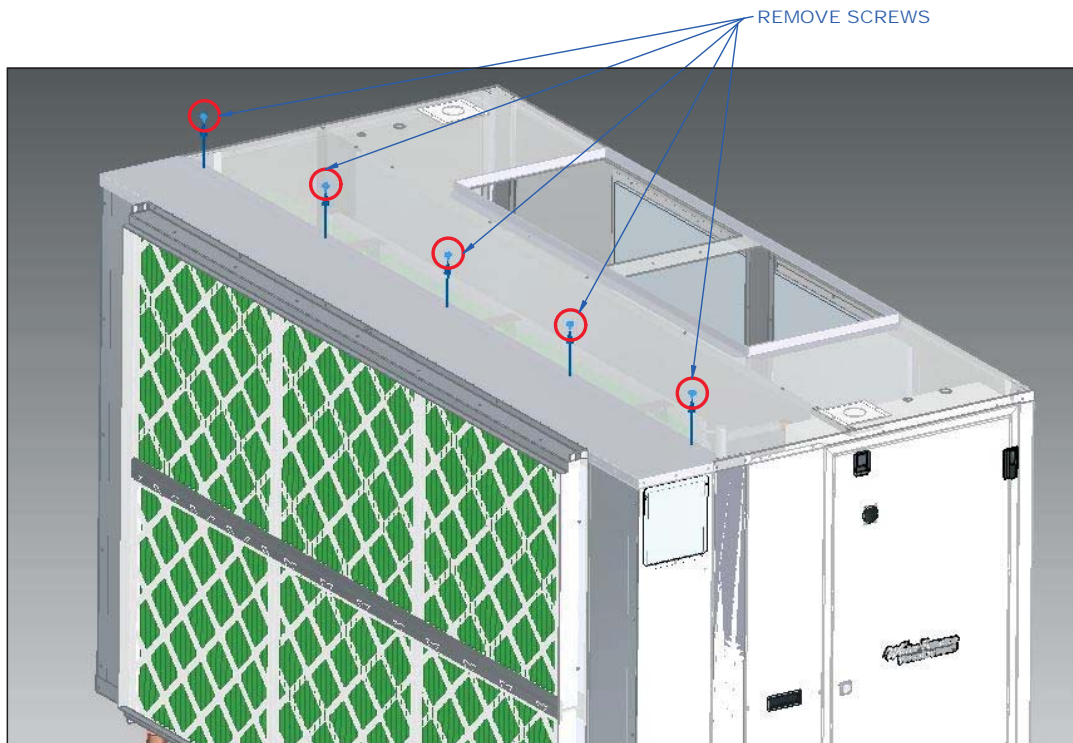

240-360 Economizer cont.

5. Lift economizer straight up to remove from unit. The bottom panel on the economizer has a tear drop shape to attach to standard unit. This bottom panel attaches directly in front of the air coil of the main unit. (See view A)
6. Remove 3 bottom panel support brackets attached with screws to main unit.

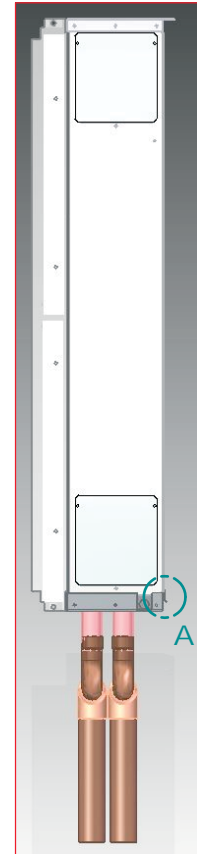
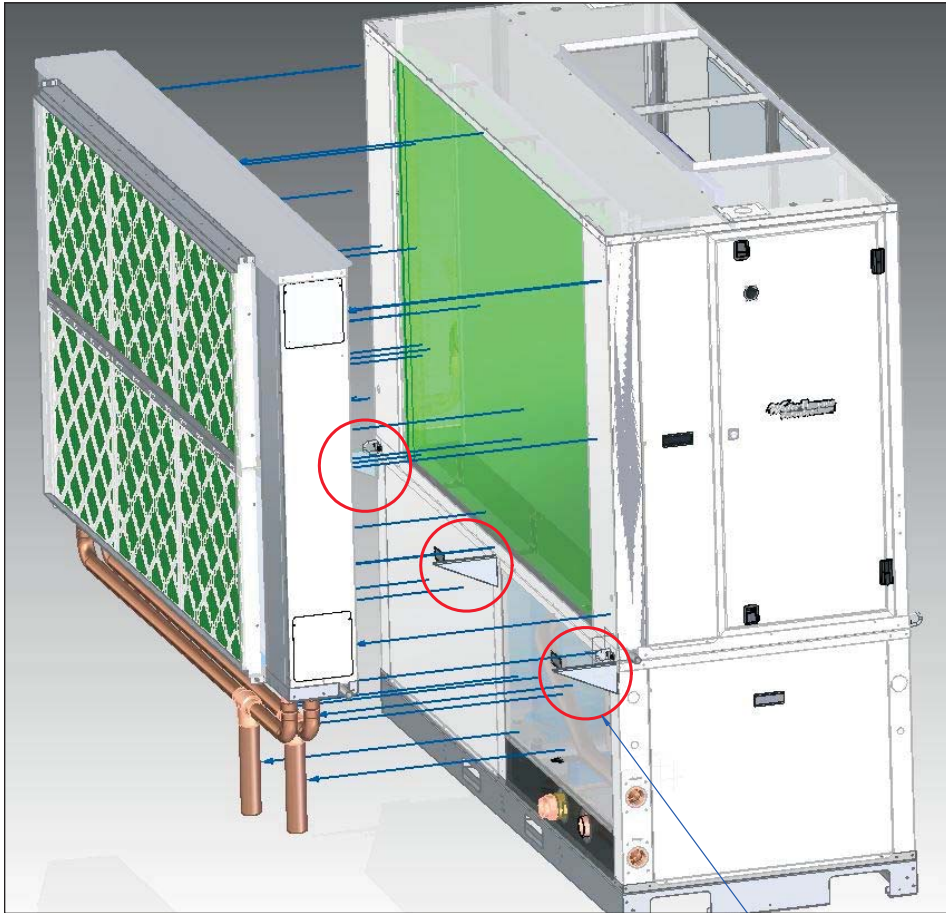

BOTTOM PANEL
SUPPORT BRACKETS

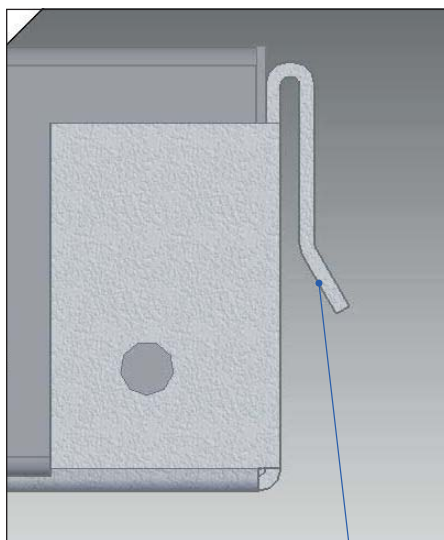

VIEW A

BOTTOM PANEL OF
ECONOMIZER UNIT
TEAR DROP SHAPE

240-360 Economizer cont.

7. If lifting rings are not attached to each corner of the air handler section then attach lifting rings as shown.

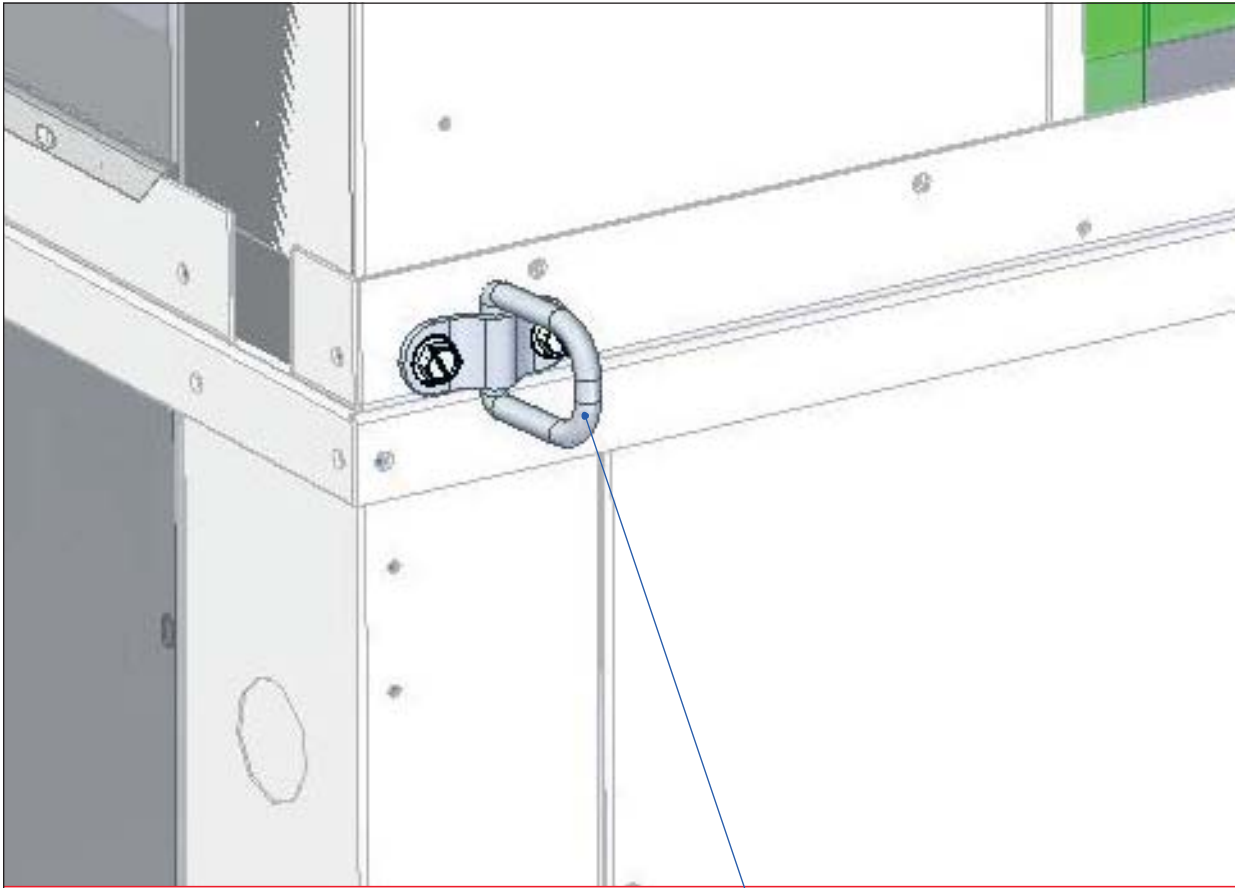

LIFTING RING (QTY 4)

240-360 Economizer cont.

8. Remove access panels opposite side of air coil
9. Loosen all quick disconnects.
10. Remove (7) 5/16" bolts holding top and bottom sections together (bolts are highlighted and labeled as cabinet fastening bolts).

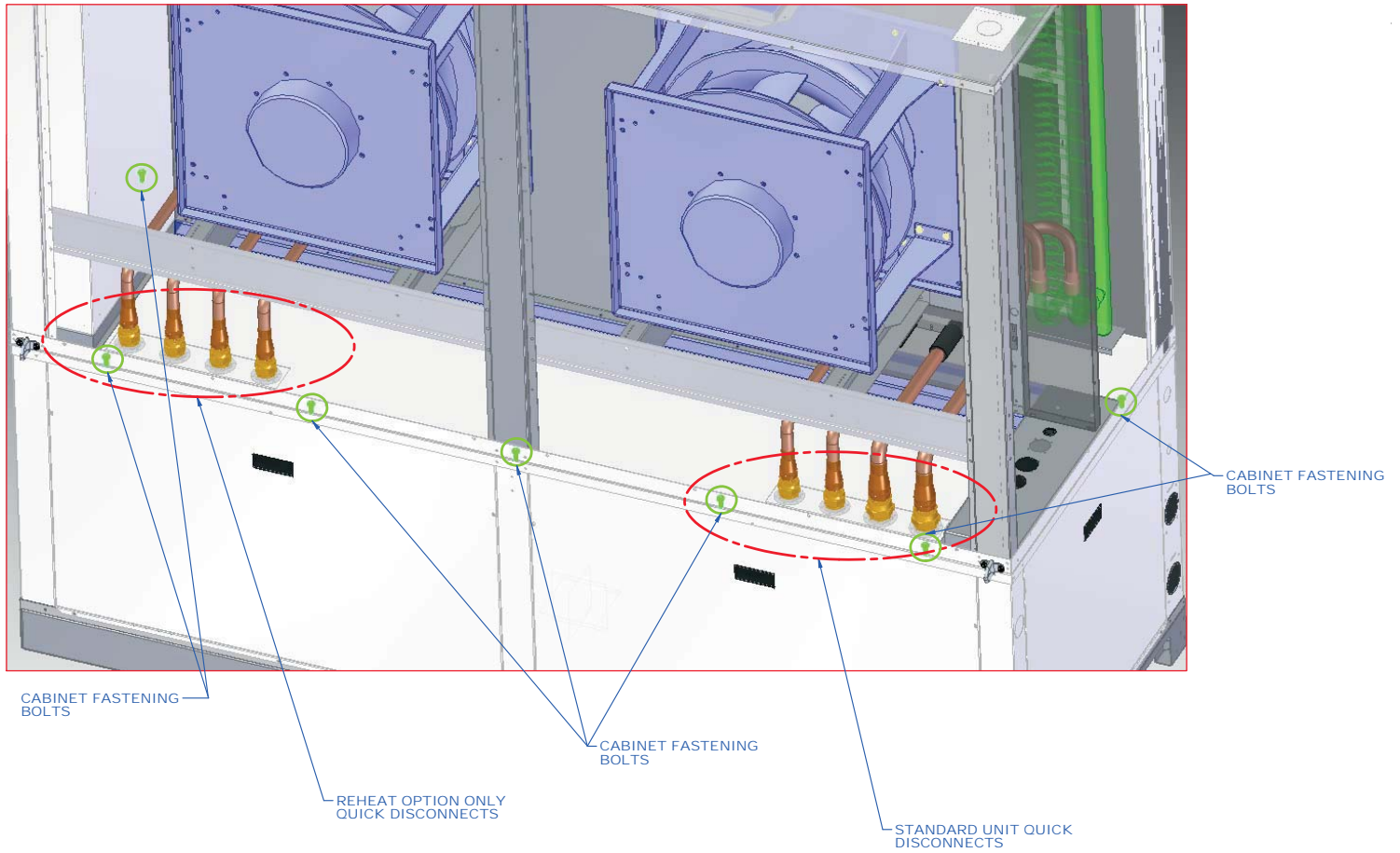

240-360 Economizer cont.

11. Remove 2 (37) pin connectors by simply unscrewing plastic rings.
12. Remove compressor wires (4) for each compressor from the ground and contactors.

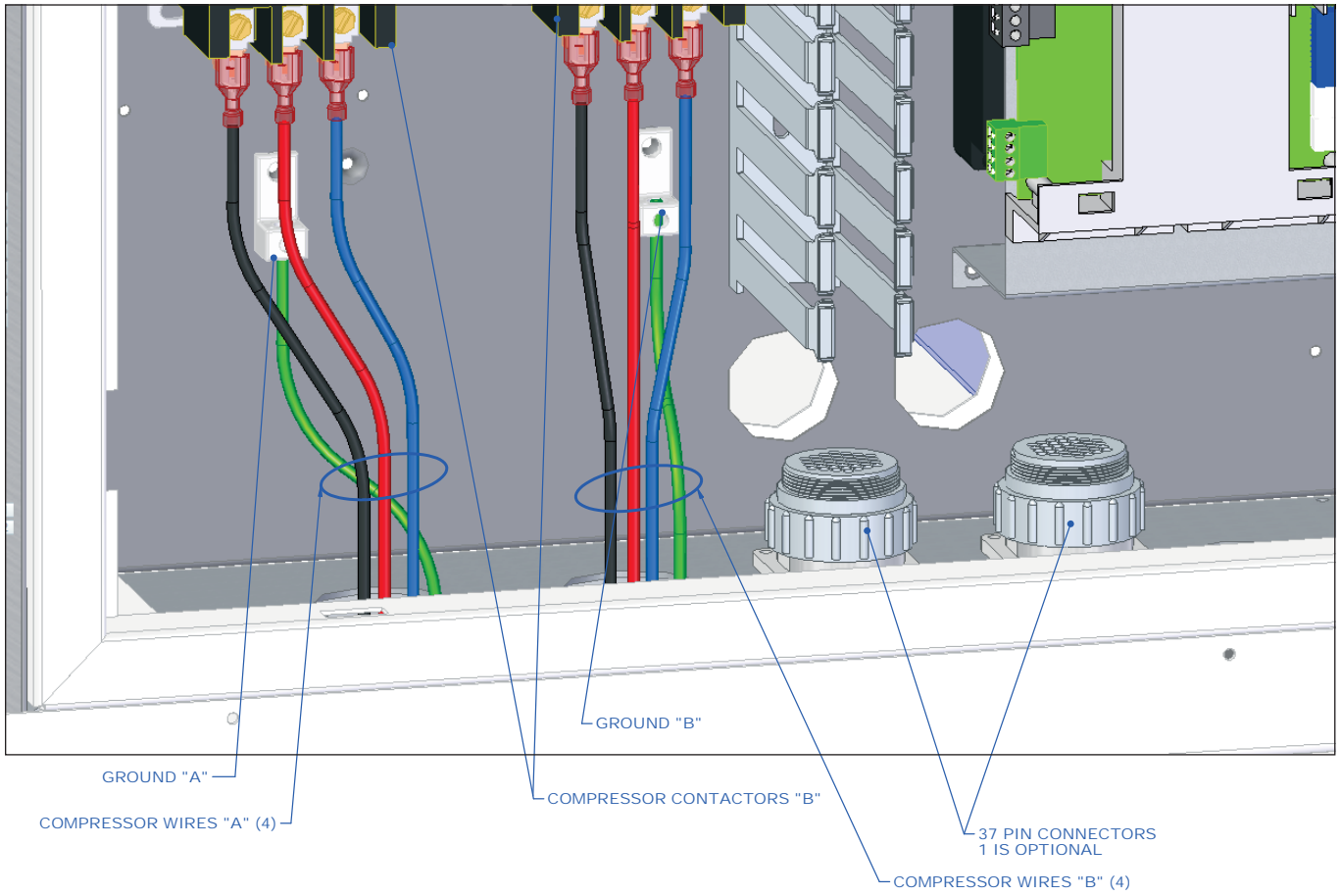

240-360 Economizer cont.

13. Use the lifting rings to pull the top portion of the unit from the bottom portion of the unit.



240-360 Economizer cont.

14. Reassemble going backwards in the disassembling operation.
15. Braze elbows in place once reassembly of the 3 units are back in place.



BRAZE ELBOWS ON
AS SHOWN

240-360 Economizer cont.

16. Quick disconnect instructions (step 17).
17. Wipe off coupling seals and threaded surfaces with a clean cloth to prevent the inclusion of dirt or any foreign material in the system. Lubricate rubber seal in male half with refrigeration oil. Thread coupling halves together by hand to insure proper mating of threads. Use proper size wrench (on coupling body hex on union nut) and tighten until coupling bodies “bottom” or a definite resistance is felt. Using a marker or ink pen, mark a line lengthwise from the union nut to the bulkhead. Then tighten an additional 1/8 to 1/4 turn. The misalignment for the line will show the degree of tightening. The final turn is necessary to insure that the knife edge metal seal bites in the brass seat of the coupling halves, forming the leakproof joint. If torque wrench is used, use torque setting 60-65 ft lbs to tighten valves.

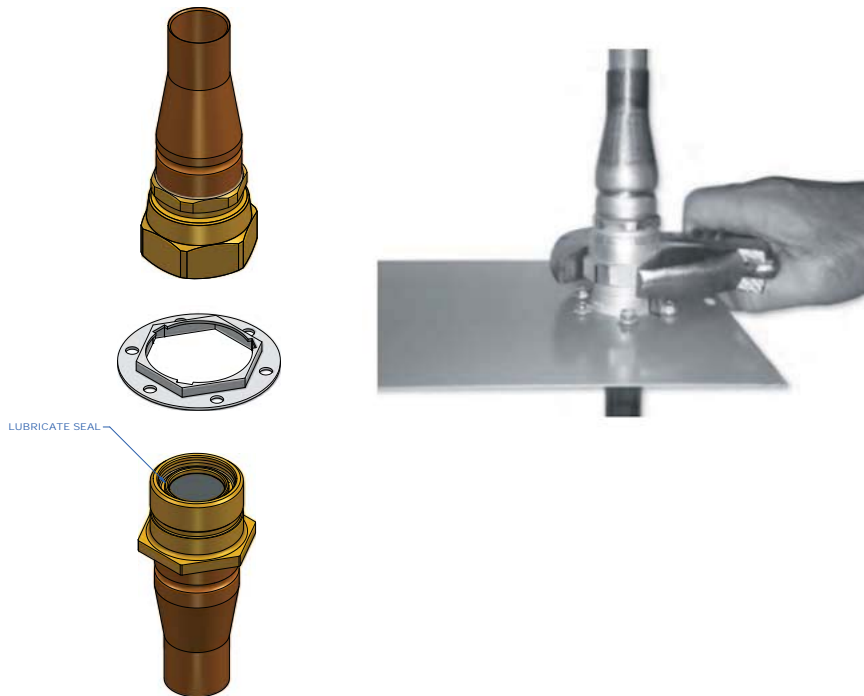

Waterside Economizer Performance Data

Model	Waterside			Airside		Cooling Capacity		Heating Capacity			
	GPM	psig	ft. hd.	CFM	Delta P (in. w.g.)	Total Btu/hr	Sensible Btu/hr	@85° F	@95° F	@105° F	
Vertical	84	21	2.5	5.8	2500	0.20	86,960	64,490	37,624	60,004	82,521
	96	24	3.2	7.34	2,800	0.23	97,176	71,621	41,397	66,012	90,776
	120	30	4.7	10.9	3,600	0.34	120,033	88,068	50,373	80,287	110,410
	150	36	8.0	18.48	4,500	0.31	152,034	111,798	64,214	102,292	140,552
	180	45	11.9	27.49	5,200	0.38	178,289	128,367	72,540	115,464	158,613
	240	60	3.8	8.78	7,500	0.21	259,528	193,186	112,795	179,755	247,063
	300	75	5.6	12.94	9,000	0.28	310,375	228,129	131,401	209,367	287,725
Horizontal	360	90	7.8	18.12	9,900	0.33	349,268	251,754	143,243	228,038	313,304
	84	21	7.1	16.33	2500	0.15	91,717	67,291	39,659	63,071	86,505
	96	24	9.0	20.69	2,800	0.18	103,358	74,984	43,766	69,601	95,466
	120	30	13.3	30.78	3,600	0.27	129,097	93,263	53,715	85,421	117,205
	150	36	8.9	20.60	4,500	0.25	160,274	116,778	67,969	108,128	148,399
	180	45	13.3	30.68	5,200	0.31	188,067	134,355	76,912	122,328	167,863

Duct System

An air outlet collar is provided on vertical top flow units and all horizontal units to facilitate a duct connection. A flexible connector is recommended for discharge and return air duct connections on metal duct systems. Uninsulated duct should be insulated with a minimum of 1-inch duct insulation. Application of the unit to uninsulated ductwork in an unconditioned space is not recommended as the unit's performance will be adversely affected.

If the unit is connected to existing ductwork, check the duct system to ensure that it has the capacity to accommodate the air required for the unit application. If the duct is too small, as in the replacement of heating only systems, larger ductwork should be installed. All existing ductwork should be checked for leaks and repaired if necessary.

The duct system should be sized to handle the design airflow quietly and efficiently. To maximize sound attenuation of the unit blower, the supply and return plenums should include an internal duct liner of fiberglass or constructed of ductboard for the first few feet. On systems employing a sheet metal duct system, canvas connectors should be used between the unit and the ductwork. If air noise or excessive airflow is a problem, the blower speed can be changed.

Water Piping

The proper water flow must be provided to each unit whenever the unit operates. To assure proper flow, use pressure/temperature ports to determine the flow rate. These ports should be located at the supply and return water connections on the unit. The proper flow rate cannot be accurately set without measuring the water pressure drop through the refrigerant-to-water heat exchanger.

All source water connections on commercial units are fittings that accept a male pipe thread (MPT). Insert the connectors by hand, then tighten the fitting with a wrench to provide a leakproof joint. When connecting to an open loop (groundwater) system, thread any copper MPT fitting into the connector and tighten in the same manner as described above.

Unit Weight

Model	Vertical Shipping Weight	Horizontal Shipping Weight
084	700	756
	(318)	(343)
096	700	756
	(318)	(343)
120	740	931
	(336)	(422)
150	1,060	1,101
	(481)	(499)
180	1,066	1,107
	(484)	(502)
240	1,816	
	(824)	
300	1892	
	(858)	
360	1970	
	(894)	

Weights are listed in lbs. (kg).

2/8/2023

Condensate Drain

On vertical units, the internal condensate drain assembly consists of a drain tube which is connected to the drain pan, a 3/4 in. PVC female adapter and a flexible connecting hose. The female adapter may exit either the front or the side of the cabinet. The adapter should be glued to the field-installed PVC condensate piping. On vertical units, a condensate hose is inside all cabinets as a trapping loop; therefore, an external trap is not necessary.

On horizontal and bottom flow units, a PVC stub or stainless steel tube is provided for condensate drain piping connection. An external trap is required (see below). If a vent is necessary, an open stand pipe may be applied to a tee in the field-installed condensate piping.

Horizontal Drain Connection (Composite Drain Pan)

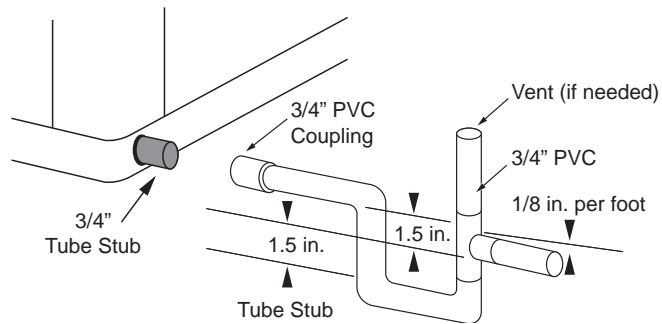

Unit Pitch for Drain

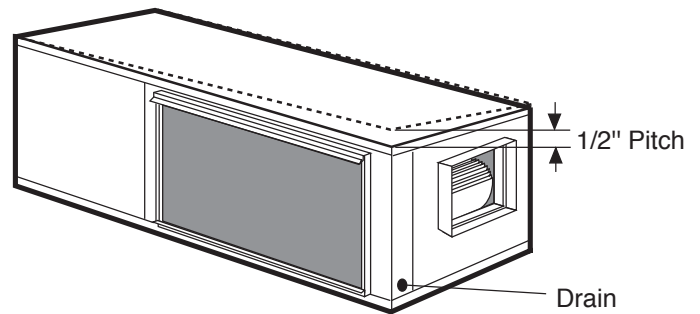

Water Quality

In ground water situations where scaling could be heavy or where biological growth such as iron bacteria will be present, a closed loop system is recommended. The heat exchanger coils in ground water systems may, over a period of time, lose heat exchange capabilities due to a buildup of mineral deposits inside. These can be cleaned, but only by a qualified service mechanic, as special solutions and pumping equipment are required. Hot water generator coils can likewise become scaled and possibly plugged. In areas

with extremely hard water, the owner should be informed that the heat exchanger may require occasional flushing. Failure to adhere to the guidelines in the water quality table could result in loss of warranty.

Units with cupronickel heat exchangers are recommended for open loop applications due to the increased resistance to build-up and corrosion, a g with reduced wear caused by acid cleaning.

Material		Copper	90/10 Cupronickel	316 Stainless Steel
pH	Acidity/Alkalinity	7 - 9	7 - 9	7 - 9
Scaling	Calcium and Magnesium Carbonate	(Total Hardness) less than 350 ppm	(Total Hardness) less than 350 ppm	(Total Hardness) less than 350 ppm
Corrosion	Hydrogen Sulfide	Less than 0.5 ppm (rotten egg smell appears at 0.5 ppm)	10 - 50 ppm	Less than 1 ppm
	Sulfates	Less than 125 ppm	Less than 125 ppm	Less than 200 ppm
	Chlorine	Less than 0.5 ppm	Less than 0.5 ppm	Less than 0.5 ppm
	Chlorides	Less than 20 ppm	Less than 125 ppm	Less than 300 ppm
	Carbon Dioxide	Less than 50 ppm	10 - 50 ppm	10 - 50 ppm
	Ammonia	Less than 2 ppm	Less than 2 ppm	Less than 20 ppm
	Ammonia Chloride	Less than 0.5 ppm	Less than 0.5 ppm	Less than 0.5 ppm
	Ammonia Nitrate	Less than 0.5 ppm	Less than 0.5 ppm	Less than 0.5 ppm
	Ammonia Hydroxide	Less than 0.5 ppm	Less than 0.5 ppm	Less than 0.5 ppm
	Ammonia Sulfate	Less than 0.5 ppm	Less than 0.5 ppm	Less than 0.5 ppm
Iron Fouling (Biological Growth)	Total Dissolved Solids (TDS)	Less than 1000 ppm	1000 - 1500 ppm	1000 - 1500 ppm
	LSI Index	+0.5 to -0.5	+0.5 to -0.5	+0.5 to -0.5
Iron Fouling (Biological Growth)	Iron, FE ²⁺ (Ferrous) Bacterial Iron Potential	< 0.2 ppm	< 0.2 ppm	< 0.2 ppm
	Iron Oxide	Less than 1 ppm, above this level deposition will occur	Less than 1 ppm, above this level deposition will occur	Less than 1 ppm, above this level deposition will occur
Erosion	Suspended Solids	Less than 10 ppm and filtered for max. of 600 micron size	Less than 10 ppm and filtered for max. of 600 micron size	Less than 10 ppm and filtered for max. of 600 micron size
	Threshold Velocity (Fresh Water)	< 6 ft/sec	< 6 ft/sec	< 6 ft/sec

NOTES: Grains = ppm divided by 17
mg/L is equivalent to ppm

2/22/12

System Cleaning and Flushing

Cleaning and Flushing

Prior to start up of any heat pump, the water circulating system must be cleaned and flushed of all dirt and debris.

If the system is equipped with water shutoff valves, the supply and return runouts must be connected together at each unit location (This will prevent the introduction of dirt into the unit, see Flushing with Water Shutoff Valve Equipped Systems illustration). The system should be filled at the water make-up connection with all air vents open. After filling, vents should be closed.

Flushing with Water Shutoff Valve Equipped Systems

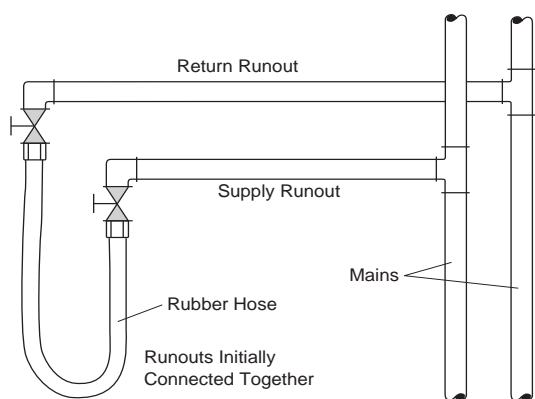

The contractor should start the main circulator with the pressure reducing valve makeup open. Vents should be checked in sequence to bleed off any trapped air and to verify circulation through all components of the system.

As water circulates through the system, the contractor should check and repair any leaks found in the piping system. Drain(s) at the lowest point(s) in the system should be opened for initial flush and blowdown, making sure water fill valves are set at the same rate. Check the pressure gauge at the pump suction and manually adjust the make-up water valve to hold the same positive pressure both before and after opening the drain valves. Flushing should continue for at least two hours, or longer if required, until drain water is clean and clear.

The supplemental heater and/or circulator pump, if used, should be shut off. All drains and vents should be opened to completely drain the system. Short-circuited supply and return runouts should now be connected to the unit supply and return connections.

Refill the system with clean water. Test the system water for acidity and treat as required to leave the water slightly alkaline (pH 7.5 to 8.5). The specified percentage of antifreeze may also be added at this time. Use commercial grade antifreeze designed for HVAC systems only. Environol™ brand antifreeze is recommended.

Once the system has been filled with clean water and antifreeze (if used), precautions should be taken to protect the system from dirty water conditions. Dirty water will result in system-wide degradation of performance, and solids may clog valves, strainers, flow regulators, etc. Additionally, the heat exchanger may become clogged which reduces compressor service life and can cause premature unit failure.

In boiler/tower application, set the loop control panel set points to desired temperatures. Supply power to all motors and start the circulating pumps. After full flow has been established through all components including the heat rejector (regardless of season), air vented and loop temperatures stabilized, each of the units will be ready for check, test and start up and for air and water balancing.

Ground Source Loop System Checkout

Once piping is completed between the unit pumping system and ground loop, final purging and charging of the loop is needed. A high pressure pump is needed to achieve adequate flow velocity in the loop to purge air and dirt particles from the loop itself. Antifreeze solution is used in most areas to prevent freezing. Flush the system adequately to remove as much air as possible; then pressurize the loop to a static pressure of 40-50 PSI (summer) or 50-75 PSI (winter). This is normally adequate for good system operation. Loop static pressure may decrease soon after initial installation, due to pipe expansion and loop temperature change. Running the unit for at least 30 minutes after the system has been completely purged of air will allow for the “break-in” period. It may be necessary to adjust static loop pressure (by adding water) after the unit has run for the first time. Loop static pressure will also fluctuate with the seasons. Pressures will be higher in the winter months than during the cooling season. This fluctuation is normal and should be considered when charging the system initially.

Ensure the pump provides adequate flow through the unit by checking pressure drop across the heat exchanger. Usually 2.25-3.0 gpm of flow per ton of cooling capacity is recommended in earth loop applications.

Open Loop Ground Water Systems

Typical open loop piping is shown below. Always maintain water pressure in the heat exchanger by placing water control valves at the outlet of the unit to prevent mineral precipitation. Use a closed, bladder-type expansion tank to minimize mineral formation due to air exposure. Insure proper water flow through the unit by checking pressure drop across the heat exchanger and comparing it to the figures in unit capacity data tables in the specification catalog. 1.5-2 gpm of flow per ton of cooling capacity is recommended in open loop applications. Due to only minor differences in flow rate from low to high, only one solenoid valve should be used. The valve should be sized for full flow.

Discharge water from the unit is not contaminated in any manner and can be disposed of in various ways, depending on local codes, i.e. recharge well, storm sewer, drain field, adjacent stream or pond, etc. Most local codes forbid the use of sanitary sewer for disposal. Consult your local building and zoning departments to assure compliance in your area.

Open System - Groundwater Application

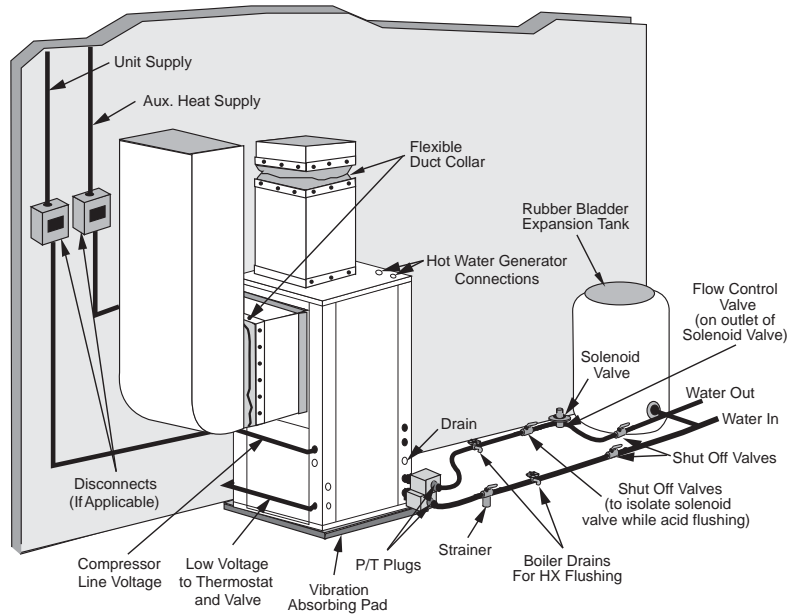

Freeze Detection

For Aurora Base Control, set SW2-1, FP1, on the printed circuit board for applications using a closed loop antifreeze solution to 15°F [-9.4°C]. On applications using an open loop/ground water system (or closed loop no antifreeze), set this dip switch to 30°F [-1.1°C], the factory default setting. (Refer to the Dip Switch Field Selection table).

Electrical Connections

General

Be sure the available power is the same voltage and phase as that shown on the unit serial plate. Line and low voltage wiring must be done in accordance with local codes or the National Electric Code, whichever is applicable.

208 Volt Operation

All 208/230 volt units are factory wired for 230 volt operation. For 208 volt operation, the red and blue transformer wires must be switched on terminal strip PS.

Aurora Base Control Box

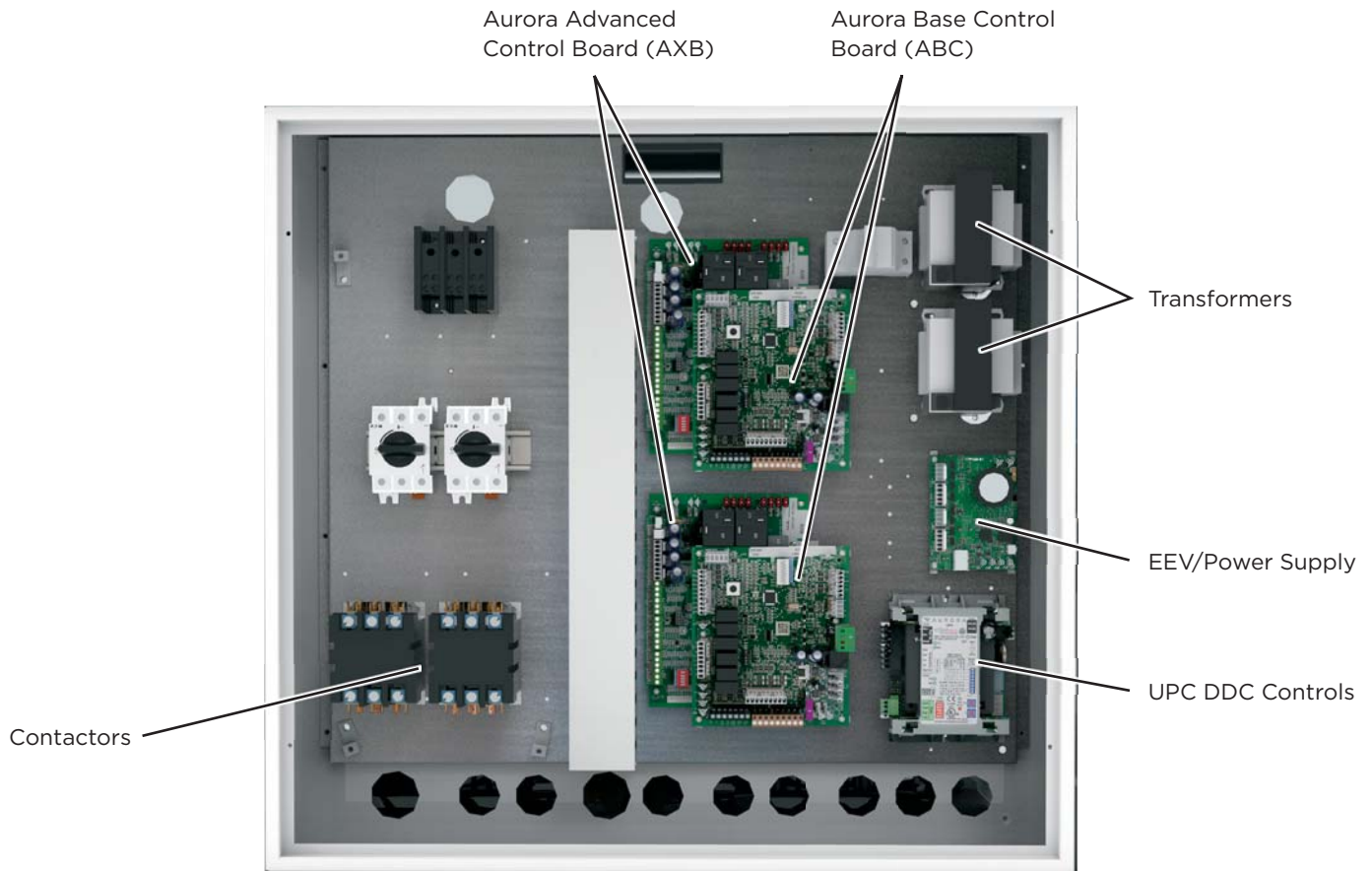

Electrical Data

Electrical Table 7-30 Ton Plenum Fan

	Model	Rated Voltage	Voltage Min/Max	Compressor (each)			Blower Motor (each) FLA	Total Unit FLA	Min Circ Amp	Max Fuse/HACR Breaker
				MCC	RLA	LRA				
Dual Capacity Compressor	084	208-230/60/3	187/253	39.5	23.3	184.0	5.3	28.6	34.4	55
		460/60/3	414/506	15.0	8.8	84.0	3.0	11.8	14.0	20
		575/60/3	518/632	13.1	8.4	60.0	2.4	10.8	12.9	20
	096	208-230/60/3	187/253	41.9	24.7	164.0	7.0	31.7	37.9	60
		460/60/3	414/506	18.7	11.0	94.0	4.0	15.0	17.8	25
		575/60/3	518/632	14.0	9.0	65.0	3.2	12.2	14.5	20
	120	208-230/60/3	187/253	50.8	30.0	240.0	7.0	37.0	44.5	70
		460/60/3	414/506	23.1	13.6	130.0	4.0	17.6	21.0	30
		575/60/3	518/632	17.3	11.1	93.7	3.2	14.3	17.1	25
Two Compressors & Compressors & Plenum Fan	150	208-230/60/3	187/253	29.7	19.0	123.0	9.2	47.2	52.0	70
		460/60/3	414/506	15.2	9.7	62.0	6.8	26.2	28.6	35
		575/60/3	518/632	11.6	7.4	50.0	5.4	20.2	22.1	25
	180	208-230/60/3	187/253	39.0	25.0	164.0	9.2	59.2	65.5	90
		460/60/3	414/506	20.0	12.8	100.0	6.8	32.4	35.6	45
		575/60/3	518/632	15.0	9.6	78.0	5.4	24.6	27.0	35
Two Compressors & Two Plenum Fans	240	208-230/60/3	187/253	44.0	28.2	240.0	9.2	74.8	81.9	110
		460/60/3	414/506	23.0	14.7	130.0	6.8	43.0	46.7	60
		575/60/3	518/632	17.6	11.3	93.7	5.4	33.5	36.3	45
	300	208-230/60/3	187/253	75.0	48.1	245.0	9.2	114.6	126.6	175
		460/60/3	414/506	29.0	18.6	125.0	6.8	50.8	55.5	70
		575/60/3	518/632	23.0	14.7	100.0	5.4	40.3	44.0	55
	360	208-230/60/3	187/253	75.0	48.1	351.0	9.2	114.6	126.6	175
		460/60/3	414/506	38.6	24.7	197.0	6.8	63.0	69.2	90
		575/60/3	518/632	35.0	22.4	135.0	5.4	55.7	61.3	80

HACR circuit breaker in USA only

3/30/2021

Unit Weight

Model	Vertical Shipping Weight	Horizontal Shipping Weight
084	700	756
	(318)	(343)
096	700	756
	(318)	(343)
120	740	931
	(336)	(422)
150	1,060	1,101
	(481)	(499)
180	1,066	1,107
	(484)	(502)
240	1,816	
	(824)	
300	1892	
	(858)	
360	1970	
	(894)	

Weights are listed in lbs. (kg).

2/8/2023

Blower Performance Data

Integrated EC Backward Curved Plenum Fan Performance

Model 084

Fan Speed	Fan RPM	Airflow [cfm] at External Static Pressure [in. wg.]																				
		0.0	0.1	0.2	0.3	0.4	0.5	0.6	0.7	0.8	0.9	1.0	1.1	1.2	1.3	1.4	1.5	1.6	1.7	1.8	1.9	2.0
1	900	1395	1315	1215	1090	940	775	495														
2	1100	1725	1640	1570	1485	1400	1280	1150	1015	870	620											
3	1300	2055	1985	1925	1865	1800	1725	1645	1550	1435	1315	1190	1060	1055	870							
4	1400	2220	2165	2100	2045	1990	1915	1850	1770	1685	1595	1490	1375	1260	1105	955						
5	1600	2555	2505	2435	2390	2335	2285	2230	2175	2110	2045	1970	1885	1800	1705	1605	1510	1375	1265			
6	1700	2715	2660	2610	2545	2505	2460	2415	2365	2305	2250	2180	2125	2050	1970	1885	1800	1695	1600	1495	1350	1275
7	1800	2810	2785	2705	2655	2600	2540	2495	2415	2355	2305	2265	2210	2175	2120	2085	2015	1965	1905	1855	1795	1705
8	1900	2970	2910	2865	2805	2775	2715	2665	2615	2575	2520	2460	2405	2360	2300	2245	2185	2130	2075	2020	1965	1895
9	2000	3145	3105	3075	3015	2945	2900	2855	2805	2745	2695	2655	2585	2520	2475	2430	2380	2305	2245	2175	2100	2030
10	2100	3320	3300	3285	3225	3115	3085	3045	2995	2915	2870	2850	2765	2680	2650	2615	2575	2480	2415	2330	2235	2165
11	2200	3460	3415	3380	3315	3245	3240	3195	3120	3085	3050	3020	2985	2915	2865	2805	2780	2715	2635	2575	2520	2475
12	2300	3625	3575	3505	3460	3425	3395	3345	3245	3255	3230	3190	3165	3120	3075	3025	2990	2950	2855	2820	2785	2715

Fan selection is accomplished through the Aurora Controls and allows four online selections of continuous fan (G), L = stage 1 (Y1), H = stage 2 (Y2), and Aux = electric heat. 3/30/21

Continuous Fan (G) can be set at any airflow. Factory setting is 1.

L = Stage 1 (Y1) factory setting is 3.

H = Stage 2 (Y2) factory setting is 8.

Electric Heat Operation (AUX) = Stage 3 factory setting is 10.

Elect heat Airflow (AUX) airflow setting should be configured for the minimum airflow needed to support the heater. Please consult heater manual.

Model 096

Fan Speed	Fan RPM	Airflow [cfm] at External Static Pressure [in. wg.]																				
		0.0	0.1	0.2	0.3	0.4	0.5	0.6	0.7	0.8	0.9	1.0	1.1	1.2	1.3	1.4	1.5	1.6	1.7	1.8	1.9	2.0
1	600	1530	1430	1205	915	525	420															
2	700	1835	1710	1530	1410	1165	870	495														
3	800	2145	2030	1895	1740	1565	1385	1125	825	570												
4	900	2530	2415	2290	2145	1985	1825	1665	1440	1200	920											
5	1000	2815	2720	2620	2505	2365	2235	2085	1915	1755	1555	1325	1115	780								
6	1100	3135	3045	2955	2830	2735	2615	2470	2335	2195	2045	1915	1745	1490	1315							
7	1200	3440	3360	3275	3195	3095	2985	2895	2750	2645	2505	2375	2225	2085	1915	1730	1525	1235				
8	1300	3745	3685	3595	3505	3415	3335	3235	3120	3035	2910	2795	2680	2555	2420	2305	2150	1955	1770	1575		
9	1400	4045	3995	3905	3830	3775	3680	3580	3500	3415	3310	3195	3165	2985	2875	2750	2630	2505	2375	2255	2070	1905
10	1500	4370	4285	4220	4150	4085	4010	3920	3850	3775	3680	3595	3505	3400	3305	3195	3075	2940	2830	2750	2645	2525
11	1600	4875	4575	4545	4480	4400	4335	4250	4200	4115	4065	3975	3865	3795	3695	3600	3500	3395	3290	3180	3085	2970
12	1700	5200	5120	5060	5000	4935	4665	4575	4510	4415	4345	4280	4210	4130	4040	3960	3875	3795	3680	3605	3515	3425

Fan selection is accomplished through the Aurora Controls and allows four online selections of continuous fan (G), L = stage 1 (Y1), H = stage 2 (Y2), and Aux = electric heat. 3/30/21

Continuous Fan (G) can be set at any airflow. Factory setting is 1.

L = Stage 1 (Y1) factory setting is 4.

H = Stage 2 (Y2) factory setting is 7.

Electric Heat Operation (AUX) = Stage 3 factory setting is 10.

Elect heat Airflow (AUX) airflow setting should be configured for the minimum airflow needed to support the heater. Please consult heater manual.

Model 120

Fan Speed	Fan RPM	Airflow [cfm] at External Static Pressure [in. wg.]																				
		0.0	0.1	0.2	0.3	0.4	0.5	0.6	0.7	0.8	0.9	1.0	1.1	1.2	1.3	1.4	1.5	1.6	1.7	1.8	1.9	2.0
1	700	1835	1710	1530	1410	1165	870	495														
2	800	2145	2030	1895	1740	1565	1385	1125	825	570												
3	900	2530	2415	2290	2145	1985	1825	1665	1440	1200	920											
4	1000	2815	2720	2620	2505	2365	2235	2085	1915	1755	1555	1325	1115	780								
5	1100	3135	3045	2955	2830	2735	2615	2470	2335	2195	2045	1915	1745	1490	1315							
6	1200	3440	3360	3275	3195	3095	2985	2895	2750	2645	2505	2375	2225	2085	1915	1730	1525	1235				
7	1300	3745	3685	3595	3505	3415	3335	3235	3120	3035	2910	2795	2680	2555	2420	2305	2150	1955	1770	1575		
8	1400	4045	3995	3905	3830	3775	3680	3580	3500	3415	3310	3195	3165	2985	2875	2750	2630	2505	2375	2255	2070	1905
9	1500	4370	4285	4220	4150	4085	4010	3920	3850	3775	3680	3595	3505	3400	3305	3195	3075	2940	2830	2750	2645	2525
10	1600	4875	4775	4545	4480	4400	4335	4250	4200	4115	4065	3975	3865	3795	3695	3600	3500	3395	3290	3180	3085	2970
11	1700	5200	5120	5060	5000	4935	4665	4575	4510	4415	4345	4280	4210	4130	4040	3960	3875	3795	3680	3605	3515	3425
12	1800	5525	5405	5310	5200	5105	4995	4860	4755	4695	4625	4555	4480	4410	4350	4295	4225	4160	4070	3985	3900	3820

Fan selection is accomplished through the Aurora Controls and allows four online selections of continuous fan (G), L = stage 1 (Y1), H = stage 2 (Y2), and Aux = electric heat. 3/30/21

Continuous Fan (G) can be set at any airflow. Factory setting is 1.

L = Stage 1 (Y1) factory setting is 4.

H = Stage 2 (Y2) factory setting is 8.

Electric Heat Operation (AUX) = Stage 3 factory setting is 10.

Elect heat Airflow (AUX) airflow setting should be configured for the minimum airflow needed to support the heater. Please consult heater manual.

Blower Performance Data cont.

Model 150

Fan Speed	Fan RPM	Airflow [cfm] at External Static Pressure [in. wg.]																				
		0.0	0.1	0.2	0.3	0.4	0.5	0.6	0.7	0.8	0.9	1.0	1.1	1.2	1.3	1.4	1.5	1.6	1.7	1.8	1.9	2.0
1	900	2780	2665	2545	2400	2230	2055	1880	1650													
2	1000	3095	2990	2885	2780	2675	2515	2345	2175	2005	1830	1590										
3	1100	3415	3325	3230	3135	3045	2905	2795	2680	2570	2460	2155	1985									
4	1200	3750	3660	3565	3470	3370	3275	3165	3055	2935	2805	2680	2530	2375	2195	1995						
5	1300	4055	3980	3905	3815	3725	3635	3540	3445	3335	3215	3100	2975	2845	2700	2545	2385	2190	1995	1802		
6	1400	4375	4305	4230	4155	4070	3985	3900	3815	3720	3620	3520	3395	3275	3160	3040	2925	2765	2605	2445	2285	2120
7	1500	4810	4700	4585	4495	4420	4345	4255	4170	4090	4015	3945	3840	3735	3635	3530	3425	3295	3165	3035	2895	2765
8	1600	5245	5095	4940	4835	4770	4685	4605	4525	4450	4385	4320	4225	4135	4035	3945	3855	3745	3640	3530	3415	3300
9	1700	5680	5490	5295	5175	5120	5025	4955	4880	4810	4755	4680	4600	4520	4435	4345	4255	4175	4090	4000	3895	3795
10	1800	6115	5885	5650	5515	5470	5365	5305	5235	5170	5125	5040	4975	4905	4835	4730	4650	4570	4490	4405	4315	4220
11	1900	6550	6280	6005	5855	5820	5705	5655	5590	5530	5495	5400	5350	5290	5235	5115	5045	4965	4890	4810	4735	4645
12	2000	6985	6675	6360	6195	6155	6045	6005	5945	5890	5865	5760	5725	5675	5635	5500	5440	5360	5290	5215	5155	5070

Fan selection is accomplished through the Aurora Controls and allows four online selections of continuous fan (G), L = stage 1 (Y1), 3/30/21

H = stage 2 (Y2), and Aux = electric heat.

Continuous Fan (G) can be set at any airflow. Factory setting is 1.

L = Stage 1 (Y1) factory setting is 2.

H = Stage 2 (Y2) factory setting is 9.

Electric Heat Operation (AUX) = Stage 3 factory setting is 10.

Elect heat Airflow (AUX) airflow setting should be configured for the minimum airflow needed to support the heater. Please consult heater manual.

Model 180

Fan Speed	Fan RPM	Airflow [cfm] at External Static Pressure [in. wg.]																				
		0.0	0.1	0.2	0.3	0.4	0.5	0.6	0.7	0.8	0.9	1.0	1.1	1.2	1.3	1.4	1.5	1.6	1.7	1.8	1.9	2.0
1	900	2454	2341	2214	2075	1923	1758	1580	1389													
2	1000	2978	2881	2773	2669	2531	2407	2253	2087	1908	1679	1432										
3	1100	3288	3202	3121	3012	2908	2800	2679	2521	2385	2230	2050	1839	1617	1281							
4	1200	3587	3507	3433	3343	3249	3145	3037	2926	2791	2659	2490	2364	2218	2037	1825	1568					
5	1300	3901	3835	3761	3664	3594	3507	3418	3319	3202	3104	2969	2864	2735	2581	2417	2230	2098	1928			
6	1400	4244	4182	4120	4057	3974	3896	3809	3727	3629	3536	3455	3326	3224	3110	2983	2833	2718	2581	2440	2293	
7	1500	4812	4738	4664	4587	4504	4438	4372	4291	4226	4134	4046	3962	3870	3780	3707	3579	3501	3404	3305	3204	3101
8	1700	5329	5262	5195	5139	5082	5020	4958	4895	4831	4752	4673	4601	4529	4455	4380	4294	4222	4145	4068	3990	3911
9	1800	5666	5607	5548	5481	5414	5353	5291	5221	5151	5086	5020	4953	4886	4811	4735	4671	4596	4523	4450	4375	4300
10	1900	6018	5957	5895	5833	5770	5712	5654	5589	5524	5463	5402	5340	5278	5208	5138	5047	4976	4907	4837	4766	4695
11	2000	6350	6287	6224	6165	6105	6045	5985	5923	5861	5799	5736	5672	5607	5541	5475	5414	5347	5281	5214	5148	5080
12	2160	6862	6805	6748	6698	6647	6588	6529	6477	6425	6364	6303	6249	6194	6131	6068	5987	5920	5854	5787	5721	5653

Fan selection is accomplished through the Aurora Controls and allows four online selections of continuous fan (G), L = stage 1 (Y1), 3/30/21

H = stage 2 (Y2), and Aux = electric heat.

Continuous Fan (G) can be set at any airflow. Factory setting is 1.

L = Stage 1 (Y1) factory setting is 3.

H = Stage 2 (Y2) factory setting is 9.

Electric Heat Operation (AUX) = Stage 3 factory setting is 10.

Elect heat Airflow (AUX) airflow setting should be configured for the minimum airflow needed to support the heater. Please consult heater manual.

Blower Performance Data cont.

Model 240

Fan Speed	Fan RPM	Airflow [cfm] at External Static Pressure [in. wg.]																				
		0.0	0.1	0.2	0.3	0.4	0.5	0.6	0.7	0.8	0.9	1.0	1.1	1.2	1.3	1.4	1.5	1.6	1.7	1.8	1.9	2.0
1	900	5755	5525	5290	5005	4725	5045	4075	3645	3205	2635											
2	1000	6610	6345	6080	5815	5550	5285	5020	4725	4425	4035	3640	3155									
3	1100	7465	7165	6870	6625	6375	5525	5965	5805	5400	5105	4810	4440	4075	3495	2915						
4	1200	7815	7650	7485	7295	7105	6915	6725	6540	6355	6095	5835	5540	5245	4755	4265	3995	3730	3075			
5	1300	8505	8355	8205	8040	7875	7705	7530	7335	7145	6925	6710	6505	6300	5975	5655	5165	4681	4568	4455	3870	3285
6	1400	9195	9020	8850	8705	8565	8395	8225	8060	7895	7710	7525	7355	7190	6975	6760	6380	6000	5500	5000	4600	4200
7	1500	9885	9785	9605	9470	9335	9180	9025	8895	8770	8575	8385	8215	8045	7850	7655	7415	7175	6740	6305	5870	5435
8	1600	10575	10545	10360	10235	10105	9930	9760	9605	9450	9325	9205	9045	8890	8725	8565	8385	8205	8005	7810	7565	7325
9	1700	11265	11105	11055	11000	10875	10680	10570	10435	10300	10160	10025	9880	9740	9590	9445	9275	9110	8880	8655	8275	7900
10	1800	11955	11860	11750	11695	11645	11430	11380	11265	11150	10995	10715	10595	10480	10340	10205	10065	9930	9770	9610	9305	9005
11	1900	12645	12615	12445	12390	12285	12180	12105	12085	12000	11830	11405	11310	11220	11090	10975	10845	10715	10565	10420	10280	10145
12	2000	13335	13230	13140	13085	12925	12885	12830	12755	12705	12665	12395	12025	11960	11840	11745	11625	11500	11360	11225	11085	10945

Fan selection is accomplished through the Aurora Controls and allows four online selections of continuous fan (G), L = stage 1 (Y1), H = stage 2 (Y2), and Aux = electric heat. 3/30/21

Continuous Fan (G) can be set at any airflow. Factory setting is 1.

L = Stage 1 (Y1) factory setting is 3.

H = Stage 2 (Y2) factory setting is 6.

Electric Heat Operation (AUX) = Stage 3 factory setting is 8.

Elect heat Airflow (AUX) airflow setting should be configured for the minimum airflow needed to support the heater. Please consult heater manual.

Model 300

Fan Speed	Fan RPM	Airflow [cfm] at External Static Pressure [in. wg.]																				
		0.0	0.1	0.2	0.3	0.4	0.5	0.6	0.7	0.8	0.9	1.0	1.1	1.2	1.3	1.4	1.5	1.6	1.7	1.8	1.9	2.0
1	900	5755	5525	5290	5005	4725	5045	4075	3645	3205	2635											
2	1000	6610	6345	6080	5815	5550	5285	5020	4725	4425	4035	3640	3155									
3	1100	7465	7165	6870	6625	6375	5525	5965	5805	5400	5105	4810	4440	4075	3495	2915						
4	1200	7815	7650	7485	7295	7105	6915	6725	6540	6355	6095	5835	5540	5245	4755	4265	3995	3730	3075			
5	1300	8505	8355	8205	8040	7875	7705	7530	7335	7145	6925	6710	6505	6300	5975	5655	5165	4681	4568	4455	3870	3285
6	1400	9195	9020	8850	8705	8565	8395	8225	8060	7895	7710	7525	7355	7190	6975	6760	6380	6000	5500	5000	4600	4200
7	1500	9885	9785	9605	9470	9335	9180	9025	8895	8770	8575	8385	8215	8045	7850	7655	7415	7175	6740	6305	5870	5435
8	1600	10575	10545	10360	10235	10105	9930	9760	9605	9450	9325	9205	9045	8890	8725	8565	8385	8205	8005	7810	7565	7325
9	1700	11265	11105	11055	11000	10875	10680	10570	10435	10300	10160	10025	9880	9740	9590	9445	9275	9110	8880	8655	8275	7900
10	1800	11955	11860	11750	11695	11645	11430	11380	11265	11150	10995	10715	10595	10480	10340	10205	10065	9930	9770	9610	9305	9005
11	1900	12645	12615	12445	12390	12285	12180	12105	12085	12000	11830	11405	11310	11220	11090	10975	10845	10715	10565	10420	10280	10145
12	2000	13335	13230	13140	13085	12925	12885	12830	12755	12705	12665	12395	12025	11960	11840	11745	11625	11500	11360	11225	11085	10945

Fan selection is accomplished through the Aurora Controls and allows four online selections of continuous fan (G), L = stage 1 (Y1), H = stage 2 (Y2), and Aux = electric heat. 3/30/21

Continuous Fan (G) can be set at any airflow. Factory setting is 1.

L = Stage 1 (Y1) factory setting is 3.

H = Stage 2 (Y2) factory setting is 8.

Electric Heat Operation (AUX) = Stage 3 factory setting is 9.

Elect heat Airflow (AUX) airflow setting should be configured for the minimum airflow needed to support the heater. Please consult heater manual.

Model 360

Fan Speed	Fan RPM	Airflow [cfm] at External Static Pressure [in. wg.]																				
		0.0	0.1	0.2	0.3	0.4	0.5	0.6	0.7	0.8	0.9	1.0	1.1	1.2	1.3	1.4	1.5	1.6	1.7	1.8	1.9	2.0
1	900	5755	5525	5290	5005	4725	5045	4075	3645	3205	2635											
2	1000	6610	6345	6080	5815	5550	5285	5020	4725	4425	4035	3640	3155									
3	1100	7465	7165	6870	6625	6375	5525	5965	5805	5400	5105	4810	4440	4075	3495	2915						
4	1200	7815	7650	7485	7295	7105	6915	6725	6540	6355	6095	5835	5540	5245	4755	4265	3995	3730	3075			
5	1300	8505	8355	8205	8040	7875	7705	7530	7335	7145	6925	6710	6505	6300	5975	5655	5165	4681	4568	4455	3870	3285
6	1400	9195	9020	8850	8705	8565	8395	8225	8060	7895	7710	7525	7355	7190	6975	6760	6380	6000	5500	5000	4600	4200
7	1500	9885	9785	9605	9470	9335	9180	9025	8895	8770	8575	8385	8215	8045	7850	7655	7415	7175	6740	6305	5870	5435
8	1600	10575	10545	10360	10235	10105	9930	9760	9605	9450	9325	9205	9045	8890	8725	8565	8385	8205	8005	7810	7565	7325
9	1700	11265	11105	11055	11000	10875	10680	10570	10435	10300	10160	10025	9880	9740	9590	9445	9275	9110	8880	8655	8275	7900
10	1800	11955	11860	11750	11695	11645	11430	11380	11265	11150	10995	10715	10595	10480	10340	10205	10065	9930	9770	9610	9305	9005
11	1900	12645	12615	12445	12390	12285	12180	12105	12085	12000	11830	11405	11310	11220	11090	10975	10845	10715	10565	10420	10280	10145
12	2000	13335	13230	13140	13085	12925	12885	12830	12755	12705	12665	12395	12025	11960	11840	11745	11625	11500	11360	11225	11085	10945

Fan selection is accomplished through the Aurora Controls and allows four online selections of continuous fan (G), L = stage 1 (Y1), H = stage 2 (Y2), and Aux = electric heat. 3/30/21

Continuous Fan (G) can be set at any airflow. Factory setting is 1.

L = Stage 1 (Y1) factory setting is 4.

H = Stage 2 (Y2) factory setting is 9.

Electric Heat Operation (AUX) = Stage 3 factory setting is 10.

Elect heat Airflow (AUX) airflow setting should be configured for the minimum airflow needed to support the heater. Please consult heater manual.

Blower Performance Data cont.

Setting Blower Speed - Variable Speed ECM

The ABC board's Yellow Config LED will flash the current ECM blower speed selections for G, low, and high continuously with a short pause in between. The speeds can also be confirmed with the AID Tool under the Setup/ECM Setup screen. The Aux will not be flashed but can be viewed in the AID Tool. The ECM blower motor speeds can be field adjusted with or without using an AID Tool.

Variable speed ECM Setup without an AID Tool

The blower speeds for G only, Low (Y1), and High (Y2/Aux) can be adjusted directly at the Aurora ABC board which utilizes the push button (SW1) on the ABC board. This procedure is outlined in the ECM Configuration Mode portion of the Aurora 'Base' Control System section. The Aux cannot be set manually without an AID Tool.

Variable speed ECM Setup with an AID Tool

A much easier method utilizes the AID Tool to change the airflow using the procedure below. First navigate to the Setup screen and then select ECM Setup. This screen displays the current ECM settings. It allows the technician

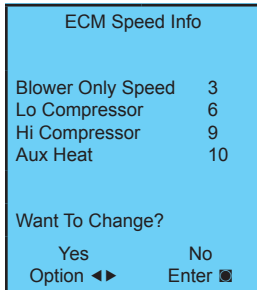

to enter the setup screens to change the ECM settings. Change the highlighted item using the ◀ and ▶ buttons and then press the ◻ button to select the item.

Selecting YES will enter ECM speed setup, while selecting NO will return to the previous screen.

ECM Speed Setup - These screens allow the technician to select the G, low, high, and auxiliary heat blower speed for the ECM blower motor. Change the highlighted item using the ▲ and ▼ buttons. Press the ◻ button to select the speed.

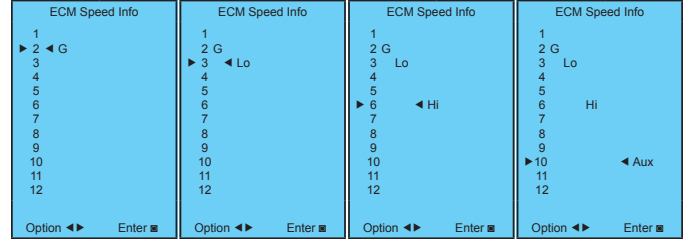

After the auxiliary heat speed setting is selected the AID Tool will automatically transfer back to the ECM Setup screen.

Cooling Airflow Setup - These screens allow the technician to select -15%, -10%, -5%, None or +5% change from the heating airflow. Change the adjustment percentage using the ▲ and ▼ buttons. Press the ◻ button to save the change.

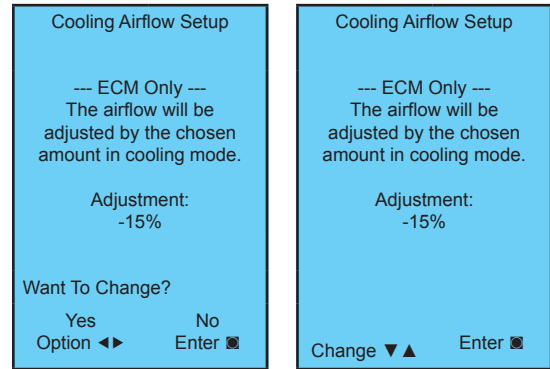

Setting Blower Speed - Variable Speed ECM - UPC Controls

Variable speed ECM blower motors have 12 selectable speeds and are factory set for optimum performance. When applicable, the speed settings may also be adjusted through the Building Automation System (BAS).



CAUTION: Disconnect all power before performing this operation.

Wiring Schematics

Single Compressor 208-230/60/3

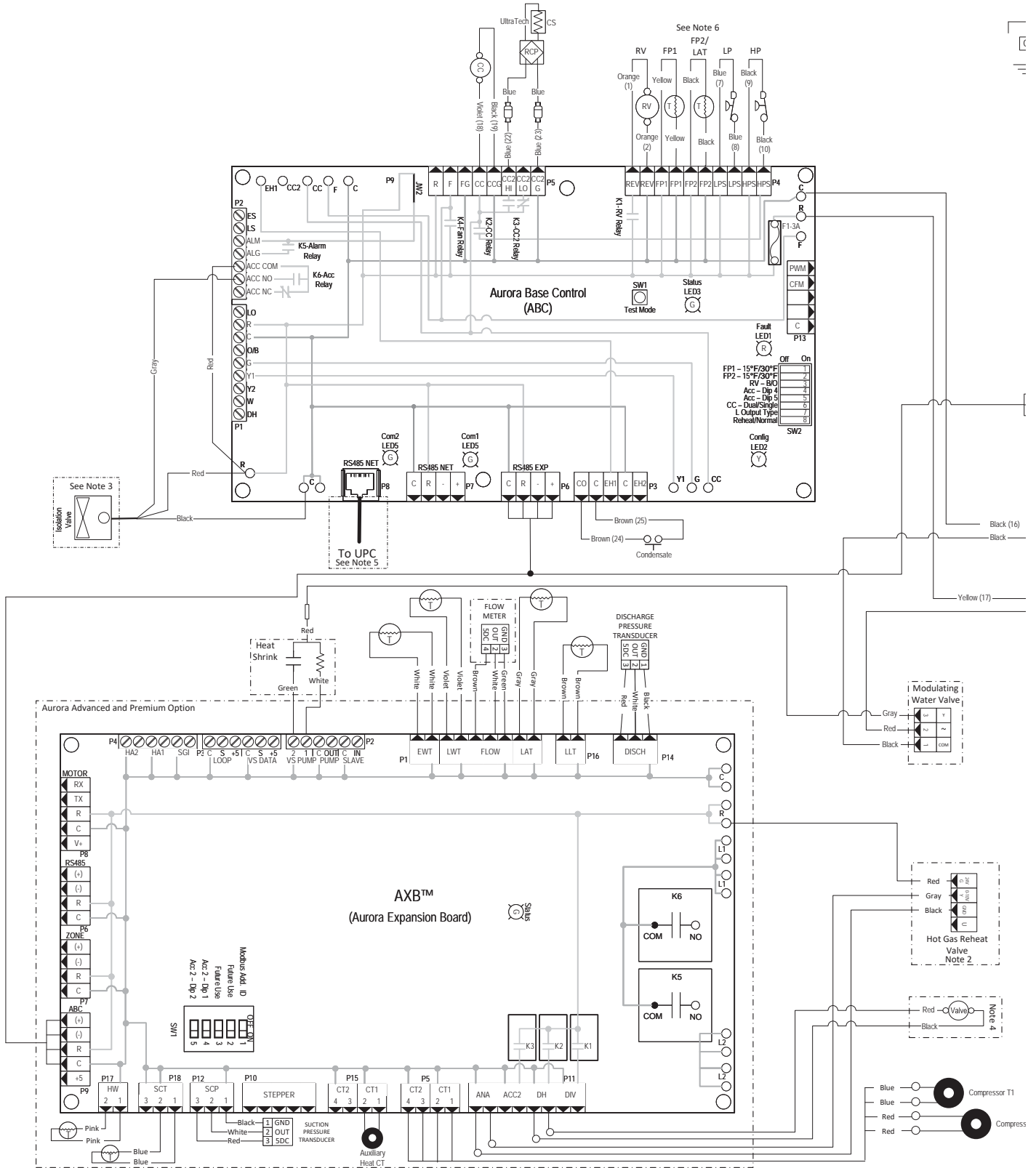

Wiring Schematics cont.

Single Compressor 208-230/60/3

97P895-01
02/14/22

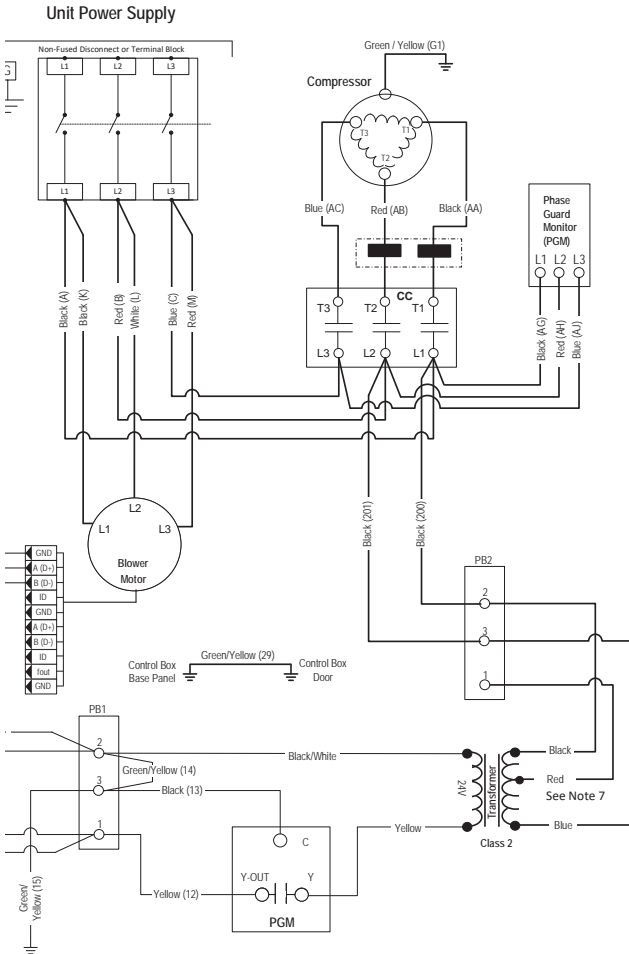

Aurora LED Flash Codes			
Slow Flash	1 second on and 1 second off		
Fast Flash	100 milliseconds on and 100 milliseconds off		
Flash Code	100 milliseconds on and 400 milliseconds off with a 2 second pause before repeating		
Random Start Delay			
Status LED (LED3, Green)	Fast Flash		
Configuration LED (LED2, Yellow)	Fast Flash		
Fault LED (LED1, Red)	Fast Flash		
Status LED (LED3, Green)	Configuration LED (LED2, Yellow)	Fault LED (LED1, Red)	
Normal Mode	ON	No Software Override	Flash ECM Setting
Control is Non-Functional	OFF	DIP Switch Override	Slow Flash
Test Mode	Slow Flash	ECM Configure Mode	Fast Flash
Lockout Active	Fast Flash	Reset Configure Mode	Off
Dehumidification Mode	Flash Code 2		
Reserved	Flash Code 3		
Reserved	Flash Code 4		
Load Shed	Flash Code 5		
ESD	Flash Code 6		
Reserved	Flash Code 7		
		Normal Mode	OFF
		Input Fault Lockout	Flash Code 1
		High Pressure Lockout	Flash Code 2
		Low Pressure Lockout	Flash Code 3
		Low Air Coil Limit Lockout - FP1	Flash Code 4
		Low Water Coil Limit Lockout - FP2	Flash Code 5
		Loss of Charge Lockout	Flash Code 6
		Condensate Overflow Lockout	Flash Code 7
		Over/Under Voltage Shutdown	Flash Code 8
		Reserved	Flash Code 9
		Compressor Monitor Lockout	Flash Code 10
		Air/Water Coil Limit Sensor Error	Flash Code 11

Accessory Relay		
Operation	SW2-4	SW2-5
Cycle with Blower	On	On
Cycle with Compressor	Off	Off
Water Valve Slow Open	On	Off
Outdoor Air Damper	Off	On

Aurora Timing Events		
Event	Normal Mode	Test Mode
Random Start Delay	5 to 80 seconds	1 second
Compressor On Delay	5 seconds	< 1 second
Compressor Minimum On Time	2 minutes	5 seconds
Compressor Short Cycle Delay	4 minutes	15 seconds
Blower Off Delay	30 seconds	2 seconds
Fault Recognition Delay - High Pressure	Less than 1 second	Less than 1 second
Start-Up Bypass - Low Pressure	2 minutes	30 seconds
Fault Recognition Delay - Low Pressure	30 seconds	30 seconds
Start-Up Bypass - Low Water/Air Coil Limit	2 minutes	30 seconds
Fault Recognition Delay - Low Water/Air Coil Limit	30 seconds	30 seconds
Fault Recognition Delay - Condensate Overflow	30 seconds	30 seconds
Thermostat Call Recognition Time	2 seconds	2 seconds
Auxiliary Heat Staging Delay	5 minutes	20 seconds
Emergency Heat Staging Delay	2 minutes	7.5 seconds
Water Valve Slow Open Delay	90 seconds	90 seconds
Reheat Delay	30 seconds	30 seconds

Notes:

- 1 - P1 (screw terminals) and P9 (Molex connector) are adjacent and share common terminals in the same order.
- 2 - Optional factory installed hot gas reheat or modulating hot gas reheat.
- 3 - Optional factory installed internal isolation valve.
- 4 - Optional waterside economizer.
- 5 - Optional UPC, see supplemental schematic for AXB and/or UPC connections, if applicable.
- 6 - LAT location with Aurora Base Controls, FP2 with Aurora Advanced and Premium Controls.
- 7 - Swap blue and red leads for 208V operation.

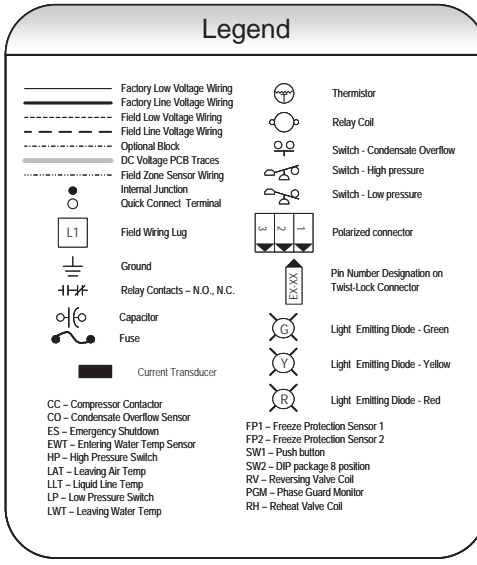
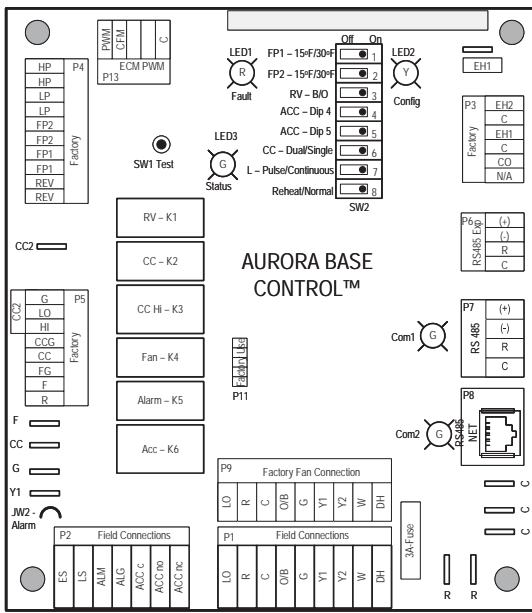

or T2

Wiring Schematics cont.

Single Compressor 460/60/3

97P895-02
07/26/22

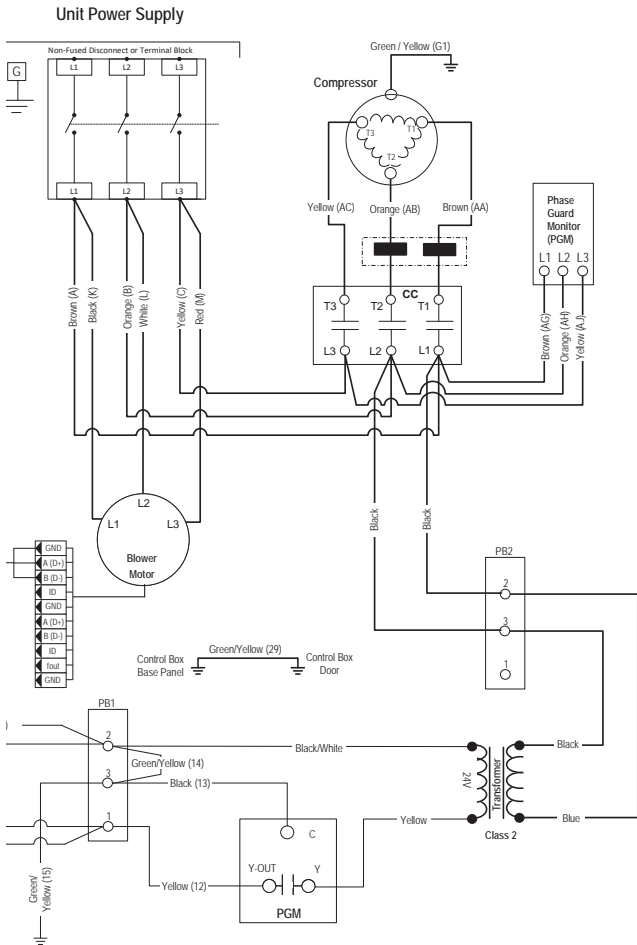

Aurora LED Flash Codes			
Slow Flash	1 second on and 1 second off		
Fast Flash	100 milliseconds on and 100 milliseconds off		
Flash Code	100 milliseconds on and 400 milliseconds off with a 2 second pause before repeating		
Random Start Delay			
Status LED (LED3, Green)	Fast Flash		
Configuration LED (LED2, Yellow)	Fast Flash		
Fault LED (LED1, Red)	Fast Flash		
Status LED (LED3, Green)	Configuration LED (LED2, Yellow)	Fault LED (LED1, Red)	
Normal Mode	ON	No Software Override	Flash ECM Setting
Control Is Non-Functional	OFF	DIP Switch Override	Slow Flash
Test Mode	Slow Flash	ECM Configure Mode	Fast Flash
Lockout Active	Fast Flash	Reset Configure Mode	Off
Dehumidification Mode	Flash Code 2	Low Air Coil Limit Lockout - FP2	Flash Code 4
Reserved	Flash Code 3	Low Water Coil Limit Lockout - FP1	Flash Code 5
Reserved	Flash Code 4	Loss of Charge Lockout	Flash Code 6
Load Shed	Flash Code 5	Condensate Overflow Lockout	Flash Code 7
ESD	Flash Code 6	Over/Under Voltage Shutdown	Flash Code 8
Reserved	Flash Code 7	Reserved	Flash Code 9
		Compressor Monitor Lockout	Flash Code 10
		Air/Water Coil Limit Sensor Error	Flash Code 11

Accessory Relay		
Operation	SW2-4	SW2-5
Cycle with Blower	On	On
Cycle with Compressor	Off	Off
Water Valve Slow Open	On	Off
Outdoor Air Damper	Off	On

Aurora Timing Events			
Event	Normal Mode	Test Mode	
Random Start Delay	5 to 80 seconds	1 second	
Compressor On Delay	5 seconds	< 1 second	
Compressor Minimum On Time	2 minutes	5 seconds	
Compressor Short Cycle Delay	4 minutes	15 seconds	
Blower Off Delay	30 seconds	2 seconds	
Fault Recognition Delay - High Pressure	Less than 1 second	Less than 1 second	
Start-Up Bypass - Low Pressure	2 minutes	30 seconds	
Fault Recognition Delay - Low Pressure	30 seconds	30 seconds	
Start-Up Bypass - Low Water/Air Coil Limit	2 minutes	30 seconds	
Fault Recognition Delay - Low Water/Air Coil Limit	30 seconds	30 seconds	
Fault Recognition Delay - Condensate Overflow	30 seconds	30 seconds	
Thermostat Call Recognition Time	2 seconds	2 seconds	
Auxiliary Heat Staging Delay	5 minutes	30 seconds	
Emergency Heat Staging Delay	2 minutes	7.5 seconds	
Water Valve Slow Open Delay	90 seconds	90 seconds	
Reheat Delay	30 seconds	30 seconds	

Notes:

- 1 - P1 (screw terminals) and P9 (Molex connector) are adjacent and share common terminals in the same order.
- 2 - Optional factory installed modulating hot gas reheat.
- 3 - Optional factory installed internal isolation valve.
- 4 - Optional waterside economizer.
- 5 - Optional UPC, see supplemental schematic for AXB and/or UPC connections, if applicable.
- 6 - LAT location with Aurora Base Controls, FP2 with Aurora Advanced and Premium Controls.

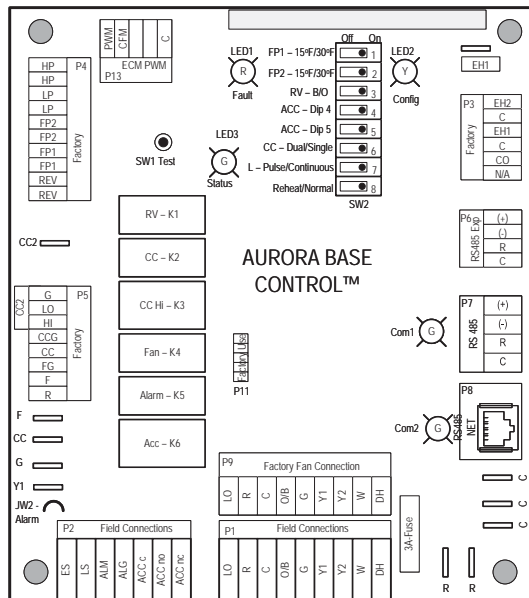

Legend

	Factory Low Voltage Wiring		Thermistor
	Factory Line Voltage Wiring		Relay Coil
	Field Low Voltage Wiring		Switch - Condensate Overflow
	Field Line Voltage Wiring		Switch - High pressure
	Optional Block		Switch - Low pressure
	DC Voltage PCB Traces		Polarized connector
	Field Zone Sensor Wiring		Pin Number Designation on Twist-Lock Connector
	Internal Junction		Light Emitting Diode - Green
	Quick Connect Terminal		Light Emitting Diode - Yellow
	Field Wiring Lug		Light Emitting Diode - Red
	Ground		
	Relay Contacts - N.O., N.C.		
	Capacitor		
	Fuse		
	Current Transducer		

CC - Compressor Contactor
 CO - Condensate Overflow Sensor
 ES - Emergency Shutdown
 FP2 - Freeze Protection Sensor 2
 EW2 - Entering Water Temp Sensor
 HP - High Pressure Switch
 LAT - Leaving Air Temp
 LLT - Liquid Line Temp
 LP - Low Pressure Switch
 LWT - Leaving Water Temp

FP1 - Freeze Protection Sensor 1
 SW2 - DIP package 8 position
 RV - Reversing Valve Coil
 PGM - Phase Guard Monitor
 RH - Reheat Valve Coil

Wiring Schematics cont.

Dual Compressor 208-230/60/3

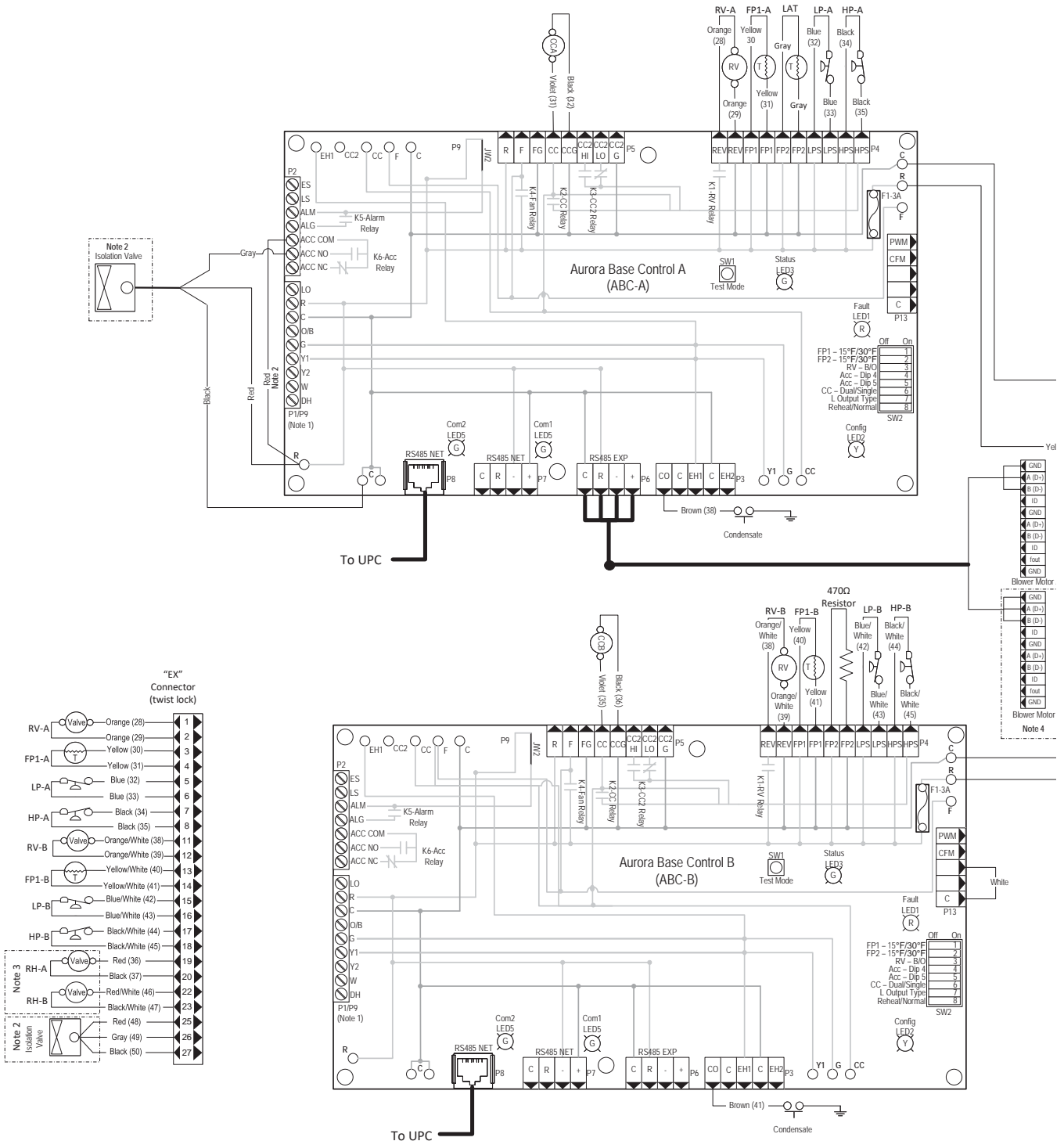

Wiring Schematics cont.

Dual Compressor 208-230/60/3

97P895-03
02/14/22

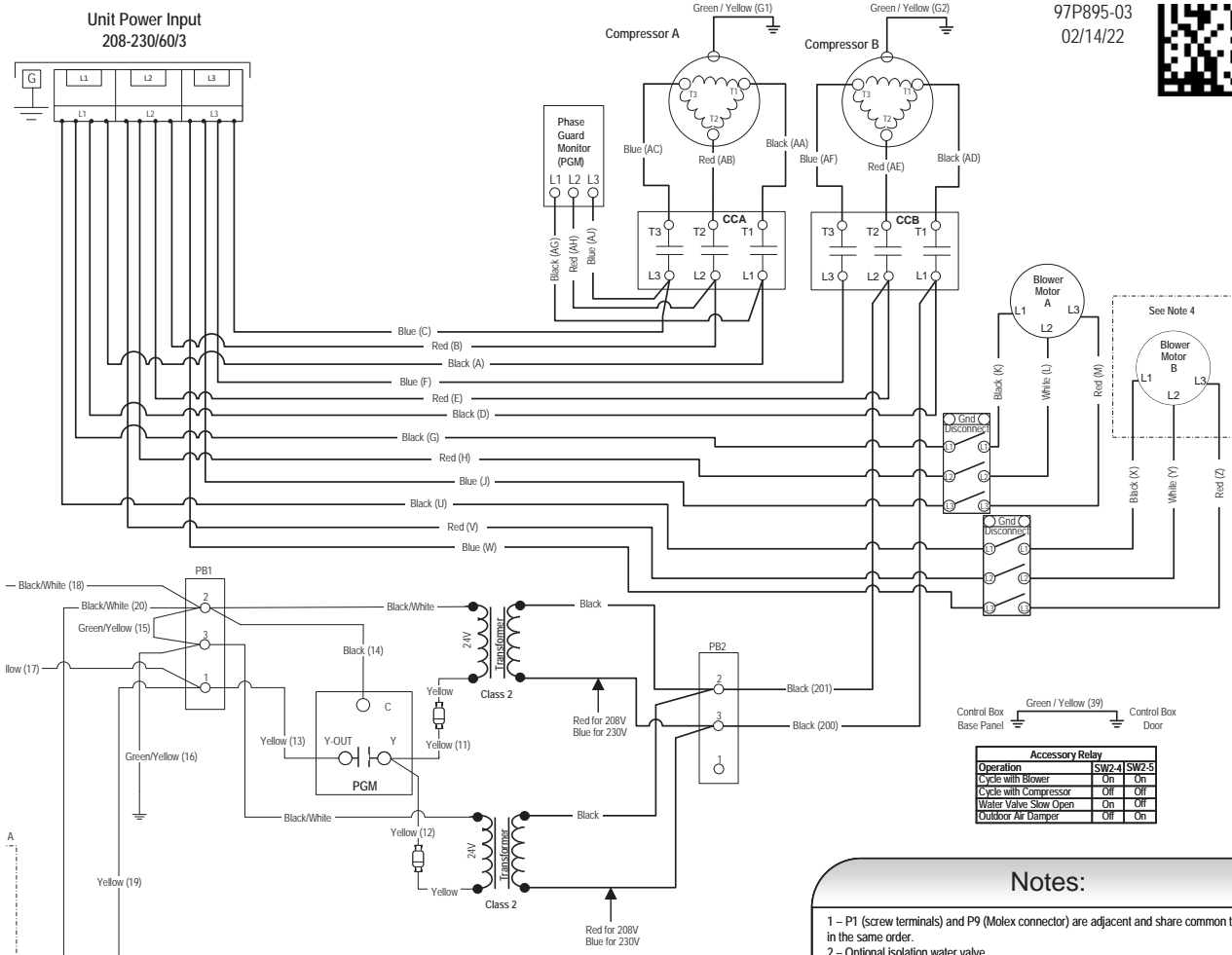

Accessory Relay		
Operation	SW2-4	SW2-5
Cycle with Blower	On	On
Cycle with Compressor	Off	Off
Water Valve Slow Open	On	Off
Outdoor Air Damper	Off	On

- Notes:**
- 1 - P1 (screw terminals) and P9 (Molex connector) are adjacent and share common terminals in the same order.
 - 2 - Optional isolation water valve.
 - 3 - Optional hot gas reheat.
 - 4 - Sizes 240-360 equipped with two blowers.

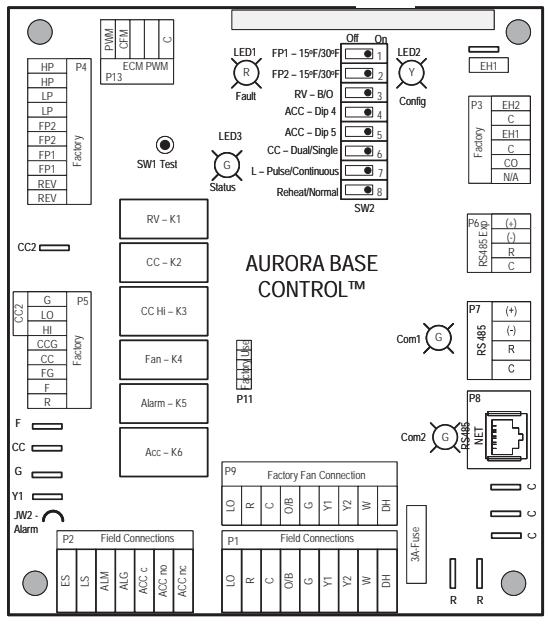

Legend

- Factory Low Voltage Wiring
- Factory Line Voltage Wiring
- Field Low Voltage Wiring
- Field Line Voltage Wiring
- Optional Block
- DC Voltage PCB Traces
- Field Zone Sensor Wiring
- Internal Junction
- Quick Connect Terminal
- Field Wiring Lug
- Ground
- Relay Contacts - N.O., N.C.
- Capacitor
- Fuse
- Thermistor
- Relay Coil
- Switch - Condensate Overflow
- Switch - High pressure
- Switch - Low pressure
- Polarized connector
- Pin Number Designation on Twist-Lock Connector
- Light Emitting Diode - Green
- Light Emitting Diode - Yellow
- Light Emitting Diode - Red

CCA - Compressor A Contactor
 CCB - Compressor B Contactor
 CO - Condensate Overflow Sensor
 ES - Emergency Shutdown
 HP1 - High Pressure Switch 1
 HP2 - High Pressure Switch 2
 LP1 - Low Pressure Switch 1
 LP2 - Low Pressure Switch 2
 FP1 - Freeze Protection Sensor 1
 FP2 - Freeze Protection Sensor 2
 F1 - Fuse

SW1 - Push button
 SW2 - DIP package 8 position
 RV1 - Reversing Valve Coil 1
 RV2 - Reversing Valve Coil 2
 PGM - Phase Guard Monitor
 RH - Reheat Valve Coil

Wiring Schematics cont.

Dual Compressor 460/60/3

Notes:

- 1 – P1 (screw terminals) and P9 (Molex connector) are adjacent and share common terminals in the same order.
- 2 – Optional isolation water valve.
- 3 – Optional hot gas reheat.
- 4 – Sizes 240-360 equipped with two blowers.

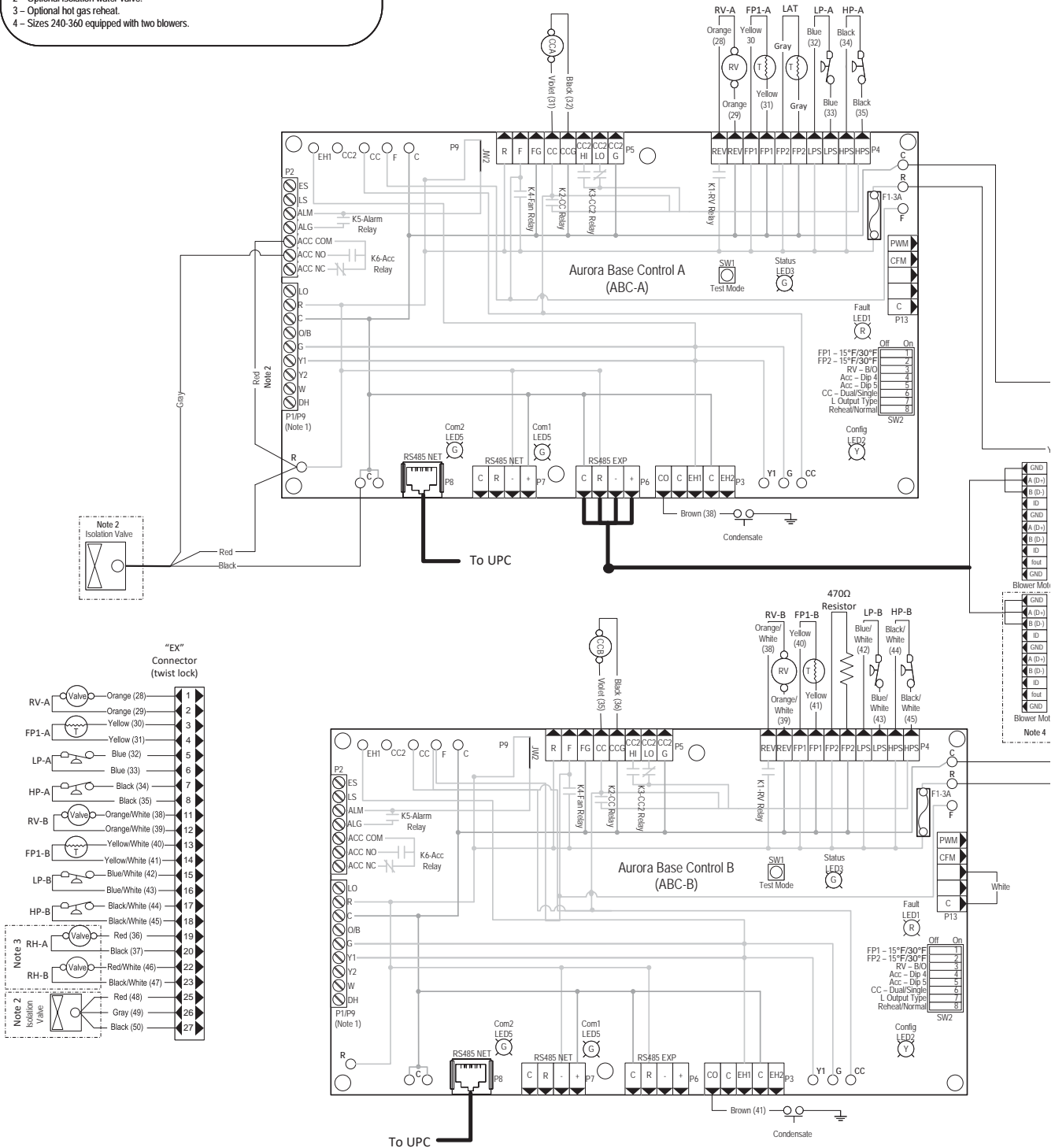

Wiring Schematics cont.

Dual Compressor 460/60/3

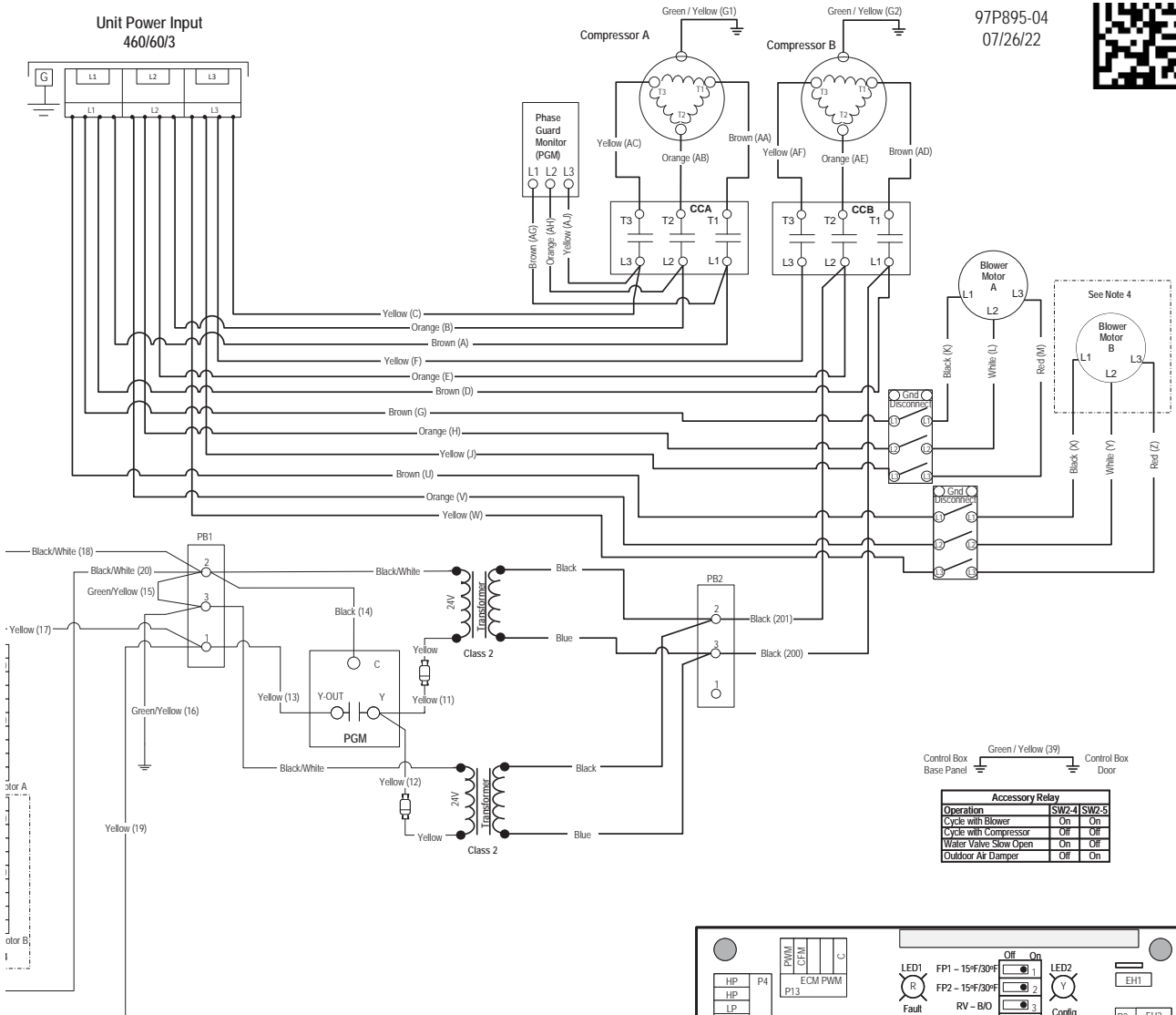

97P895-04
07/26/22



Color A
Color B

Accessory Relay		
Operation	SW2-4	SW2-5
Cycle with Blower	On	On
Cycle with Compressor	Off	Off
Water Valve Slow Open	On	Off
Outdoor Air Damper	Off	On

Legend

Factory Low Voltage Wiring	Thermistor
Factory Line Voltage Wiring	Relay Coil
Field Low Voltage Wiring	Switch - Condensate Overflow
Field Line Voltage Wiring	Switch - High pressure
Optional Block	Switch - Low pressure
DC Voltage PCB Traces	Polarized connector
Field Zone Sensor Wiring	Pin Number Designation on Twist-Lock Connector
Internal Junction	Light Emitting Diode - Green
Quick Connect Terminal	Light Emitting Diode - Yellow
Field Wiring Lug	Light Emitting Diode - Red
Ground	SW1 - Push button
Relay Contacts - N.O., N.C.	SW2 - DIP package 8 position
Capacitor	RV1 - Reversing Valve Coil 1
Fuse	RV2 - Reversing Valve Coil 2
	PGM - Phase Guard Monitor
	RH - Reheat Valve Coil

CCA - Compressor A Contactor
CCB - Compressor B Contactor
CO - Condensate Overflow Sensor
ES - Emergency Shutdown
HP1 - High Pressure Switch 1
HP2 - High Pressure Switch 2
LP1 - Low Pressure Switch 1
LP2 - Low Pressure Switch 2
FP1 - Freeze Protection Sensor 1
FP2 - Freeze Protection Sensor 2
F1 - Fuse

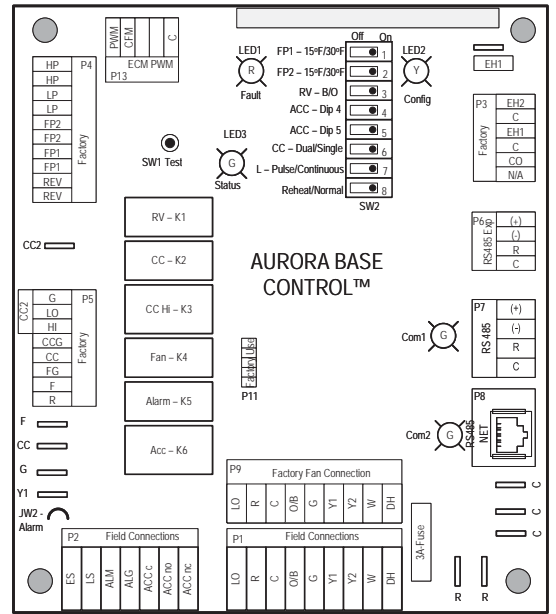

Wiring Schematics cont.

Dual Compressor Aurora Advanced and Premium 208-230/60/3

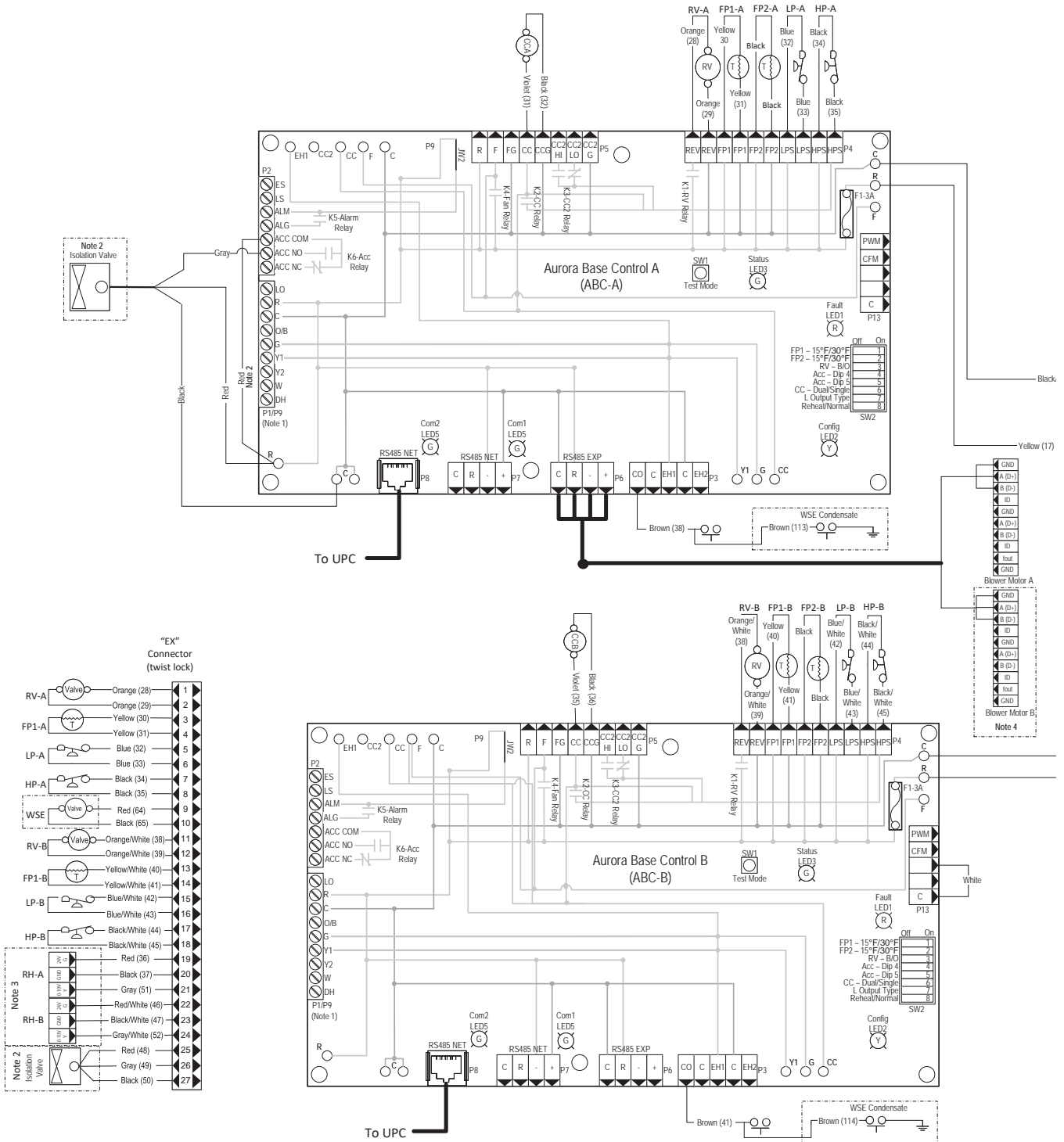

Wiring Schematics cont.

Dual Compressor Aurora Advanced and Premium 208-230/60/3

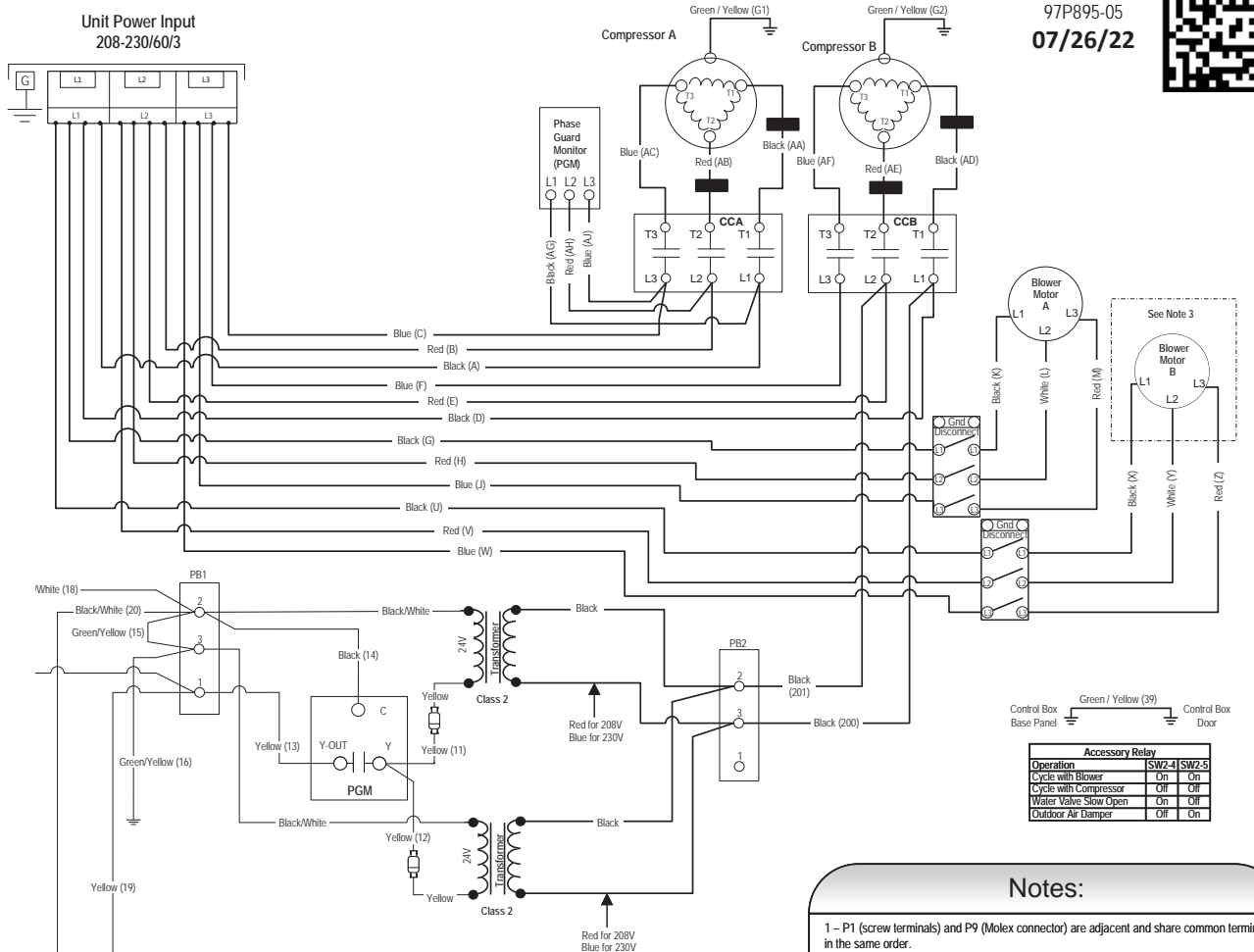

97P895-05
07/26/22



Accessory Relay		
Operation	SW2-4	SW2-5
Cycle with Blowers	On	On
Cycle with Compressor	Off	Off
Water Valve Slow Open	On	Off
Outdoor Air Damper	Off	On

Notes:

- 1 - P1 (screw terminals) and P9 (Molex connector) are adjacent and share common terminals in the same order.
- 2 - Optional isolation water valve.
- 3 - Sizes 240-360 equipped with two blowers.

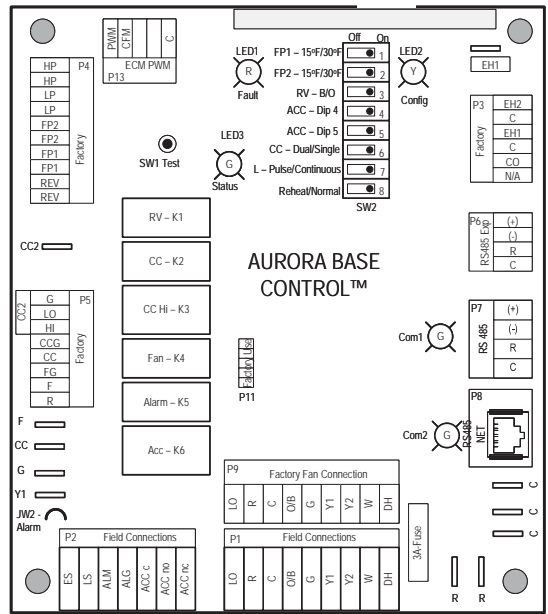

Legend

- Factory Low Voltage Wiring
- Factory Line Voltage Wiring
- Field Low Voltage Wiring
- Field Line Voltage Wiring
- Optional Block
- DC Voltage PCB Traces
- Field Zone Sensor Wiring
- Internal Junction
- Quick Connect Terminal
- Field Wiring Lug
- Ground
- Relay Contacts - N.O., N.C.
- Capacitor
- Fuse
- Current Transducer
- Thermistor
- Relay Coil
- Switch - Condensate Overflow
- Switch - High pressure
- Switch - Low pressure
- Polarized connector
- Pin Number Designation on Twist-Lock Connector
- Light Emitting Diode - Green
- Light Emitting Diode - Yellow
- Light Emitting Diode - Red
- SW1 - Push button
- SW2 - DIP package 8 position
- RV1 - Reversing Valve Coil 1
- RV2 - Reversing Valve Coil 2
- PGM - Phase Guard Monitor
- RH - Reheat Valve Coil

Wiring Schematics cont.

Dual Compressor Aurora Advanced and Premium 460/60/3

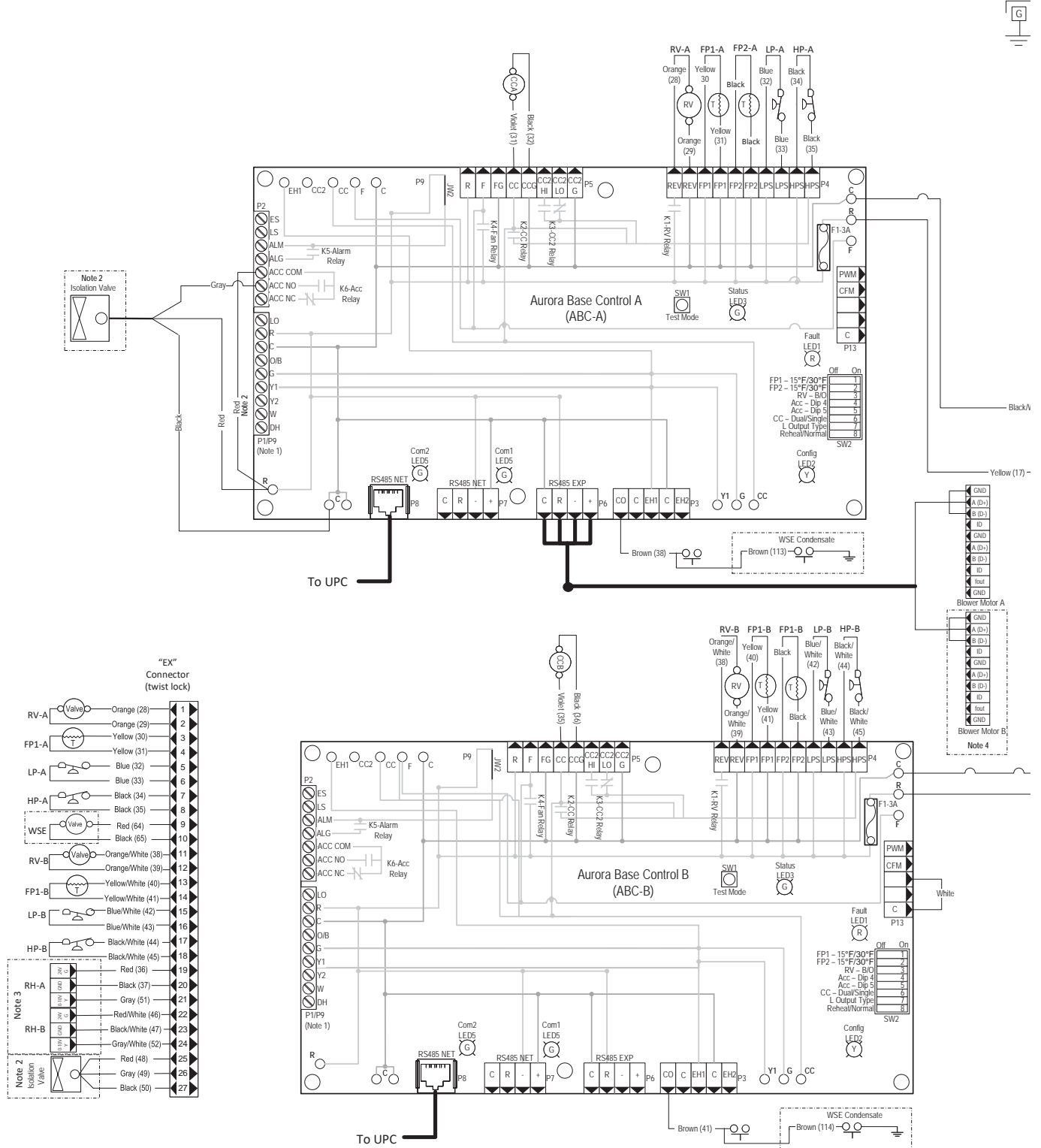

Wiring Schematics cont.

Dual Compressor Aurora Advanced and Premium 460/60/3

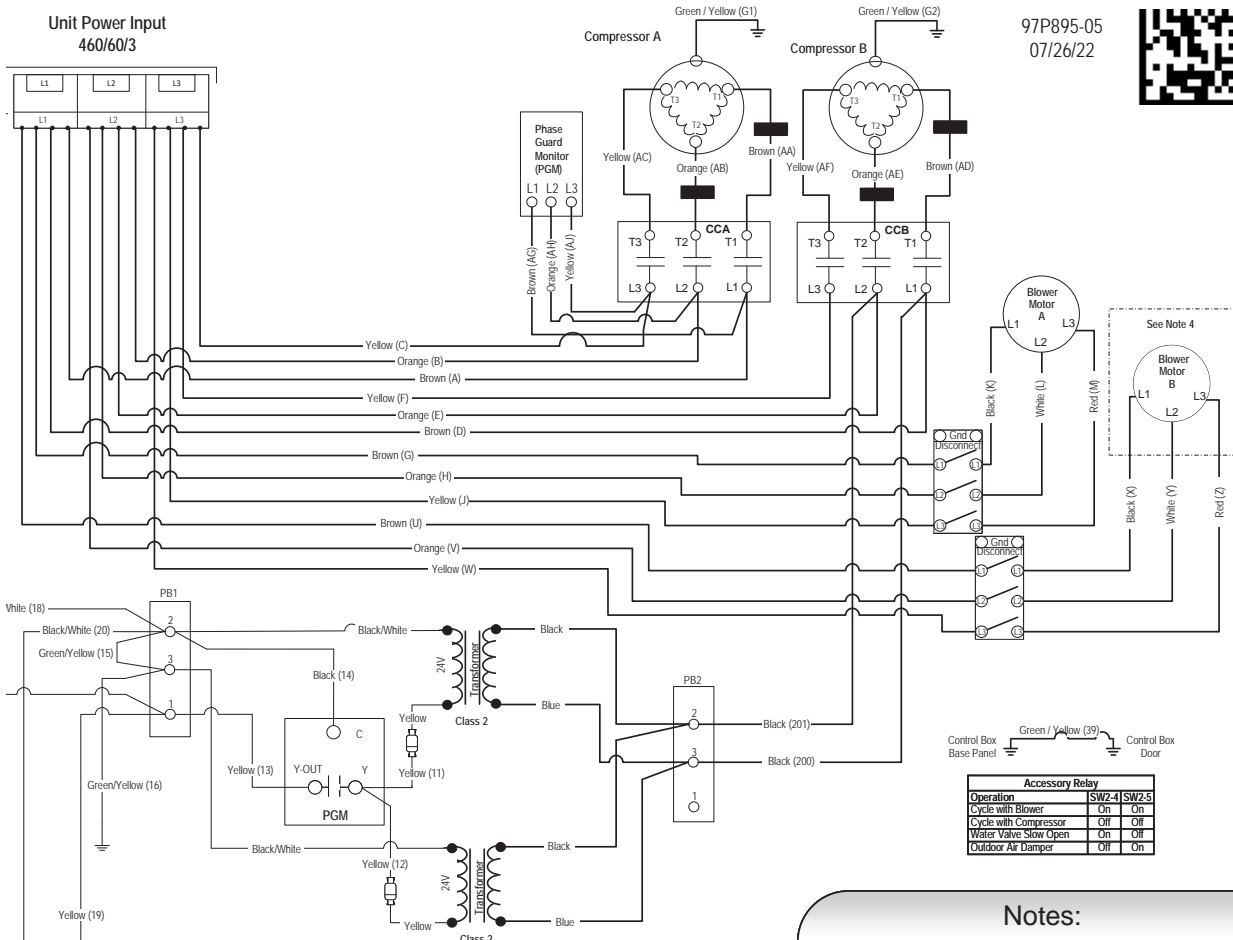

97P895-05
07/26/22



Accessory Relay		
Operation	SW2-4	SW2-5
Cycle with Blower	On	On
Cycle with Compressor	Off	Off
Water Valve Slow Open	On	Off
Outdoor Air Damper	Off	On

Notes:

- 1 - P1 (screw terminals) and P9 (Molex connector) are adjacent and share common terminals in the same order.
- 2 - Optional isolation water valve.
- 3 - Optional hot gas reheat.
- 4 - Sizes 240-360 equipped with two blowers.

Legend

	Factory Low Voltage Wiring		Thermistor
	Factory Line Voltage Wiring		Relay Coil
	Field Low Voltage Wiring		Switch - Condensate Overflow
	Field Line Voltage Wiring		Switch - High pressure
	Optional Block		Switch - Low pressure
	DC Voltage PCB Traces		Polarized connector
	Field Zone Sensor Wiring		Pin Number Designation on Twist-Lock Connector
	Internal Junction		Light Emitting Diode - Green
	Quick Connect Terminal		Light Emitting Diode - Yellow
	Field Wiring Lug		Light Emitting Diode - Red
	Ground		SW1 - Push button
	Relay Contacts - N.O., N.C.		SW2 - DIP package 8 position
	Capacitor		RV1 - Reversing Valve Coil 1
	Fuse		RV2 - Reversing Valve Coil 2
	Current Transducer		PGM - Phase Guard Monitor
	CCA - Compressor A Contactor		RH - Reheat Valve Coil
	CCB - Compressor B Contactor		
	CO - Condensate Overflow Sensor		
	ES - Emergency Shutdown		
	HP1 - High Pressure Switch 1		
	HP2 - High Pressure Switch 2		
	LP1 - Low Pressure Switch 1		
	LP2 - Low Pressure Switch 2		
	FP1 - Freeze Protection Sensor 1		
	FP2 - Freeze Protection Sensor 2		
	F1 - Fuse		

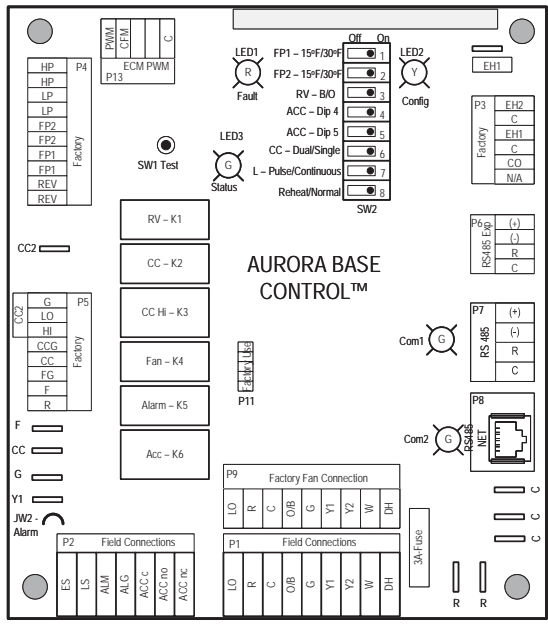

Wiring Schematics cont.

Aurora Advanced and Premium Controls Add-on

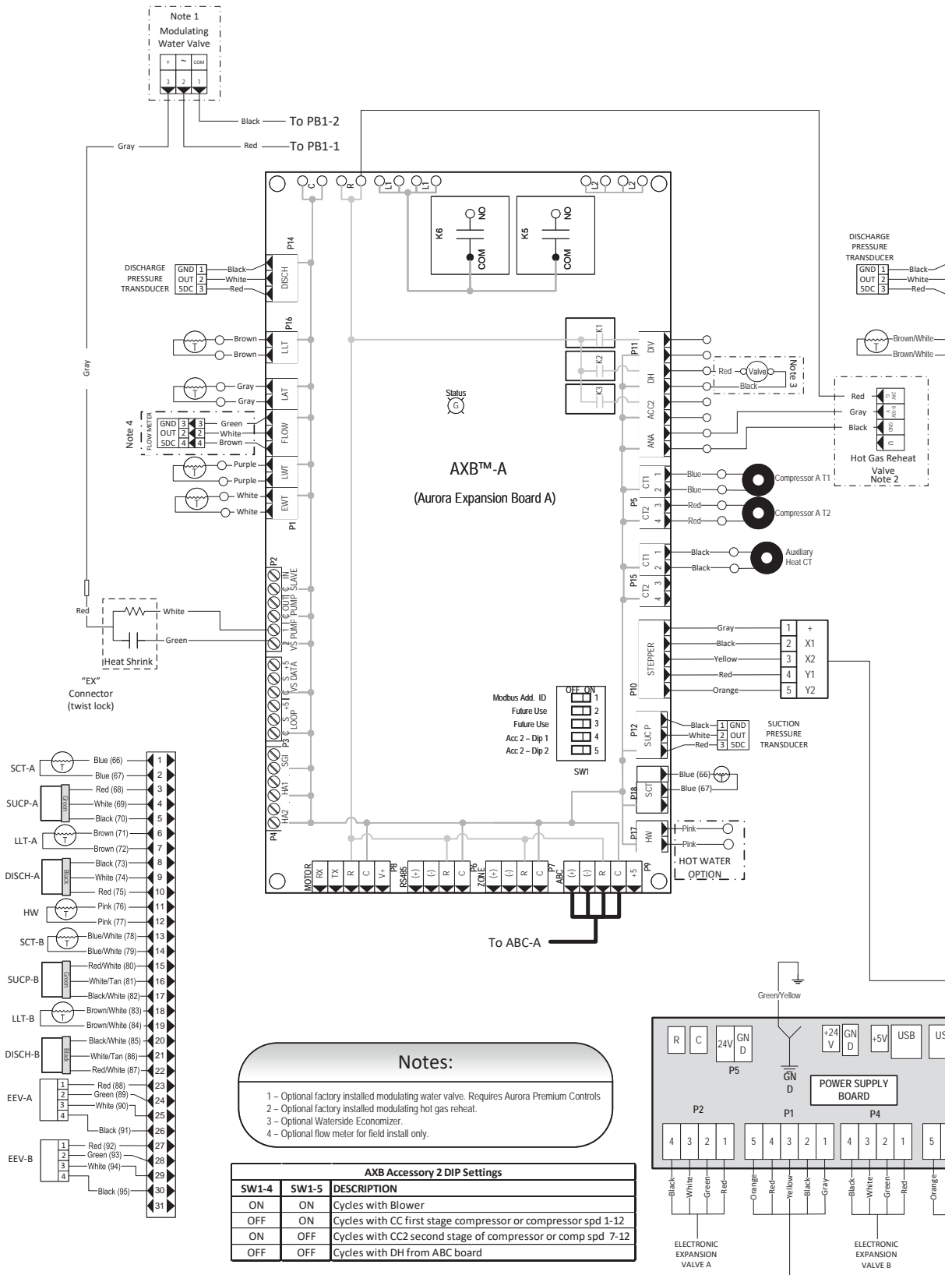

Wiring Schematics cont.

Aurora Advanced and Premium Controls Add-on

3/28/22
07/26/22

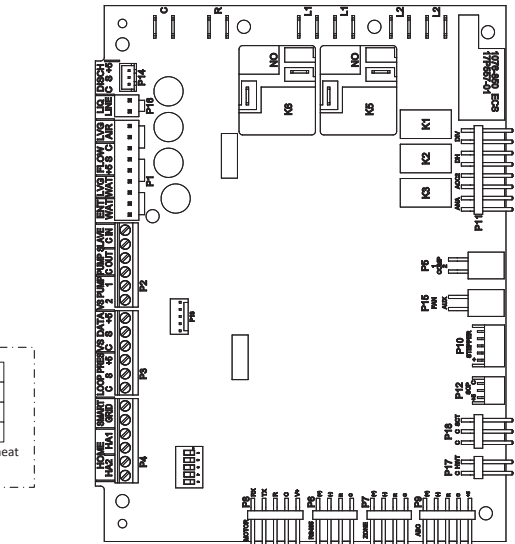
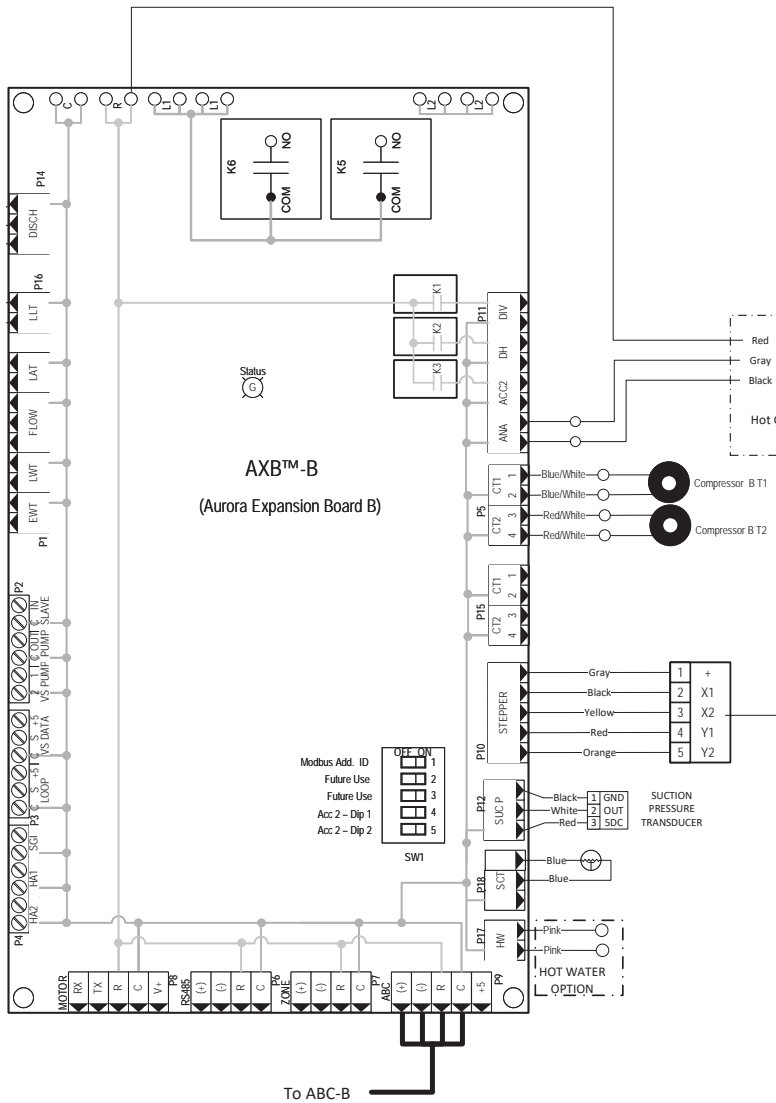

Legend

- Factory Low Voltage Wiring
- Factory Line Voltage Wiring
- Field Low Voltage Wiring
- Field Line Voltage Wiring
- Optional Block
- DC Voltage PCB Traces
- Field Zone Sensor Wiring
- Internal Junction
- Quick Connect Terminal
- Field Wiring Lug
- Ground
- Relay Contacts - N.O., N.C.
- Capacitor
- Fuse
- Current Transducer (CT)
- Thermistor
- Relay Coil
- Switch - Condensate Overflow
- Switch - High pressure
- Switch - Low pressure
- Polarized connector
- Pin Number Designation on Twist-Lock Connector
- Light Emitting Diode - Green
- Light Emitting Diode - Yellow
- Light Emitting Diode - Red

DISCH - Discharge Pressure
 EWT - Entering Water Temperature
 HW - Hot Water Generation
 LAT - Leaving Air Temperature
 LLT - Liquid Line Temperature
 LWT - Leaving Water Temperature
 SCT - Suction Temperature
 SUCP - Suction Pressure

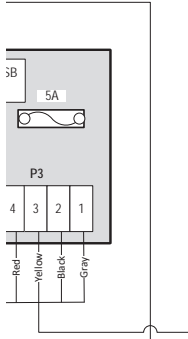

Aurora Timing Events		
Event	Normal Mode	Test Mode
Random Start Delay	5 to 80 seconds	1 second
Compressor On Delay	5 seconds	< 1 second
Compressor Minimum On Time	2 minutes	5 seconds
Compressor Short Cycle Delay	4 minutes	15 seconds
Blower Off Delay	30 seconds	2 seconds
Fault Recognition Delay - High Pressure	Less than 1 second	Less than 1 second
Start-Up Bypass - Low Pressure	2 minutes	30 seconds
Fault Recognition Delay - Low Pressure	30 seconds	30 seconds
Start-Up Bypass - Low Water/Air Coil Limit	2 minutes	30 seconds
Fault Recognition Delay - Low Water/Air Coil Limit	30 seconds	30 seconds
Fault Recognition Delay - Condensate Overflow	30 seconds	30 seconds
Thermostat Call Recognition Time	2 seconds	2 seconds
Auxiliary Heat Staging Delay	5 minutes	20 seconds
Emergency Heat Staging Delay	2 minutes	7.5 seconds
Water Valve Slow Open Delay	90 seconds	90 seconds
Reheat Delay	30 seconds	30 seconds

Aurora LED Flash Codes			
Slow Flash	1 second on and 1 second off		
Fast Flash	100 milliseconds on and 100 milliseconds off		
Flash Code	100 milliseconds on and 400 milliseconds off with a 2 second pause before repeating		
Random Start Delay			
Status LED (LED3, Green)	Fast Flash		
Configuration LED (LED2, Yellow)	Fast Flash		
Fault LED (LED1, Red)	Fast Flash		
Status LED (LED3, Green)	Configuration LED (LED2, Yellow)	Fault LED (LED1, Red)	
Normal Mode	ON	No Software Override	Flash ECM Setting
Control is Non-Functional	OFF	DIP Switch Override	Slow Flash
Test Mode	Slow Flash	ECM Configure Mode	Fast Flash
Lockout Active	Fast Flash	Reset Configure Mode	Off
Dehumidification Mode	Flash Code 2		
Reserved	Flash Code 3		Low Air Coil Limit Lockout - FP2
Reserved	Flash Code 4		Flash Code 5
Load Shed	Flash Code 5		Loss of Charge Lockout
ESD	Flash Code 6		Flash Code 7
Reserved	Flash Code 7		Flash Code 8
			Flash Code 9
			Flash Code 10
			Flash Code 11

Wiring Schematics cont.

Single Compressor 575/60/3

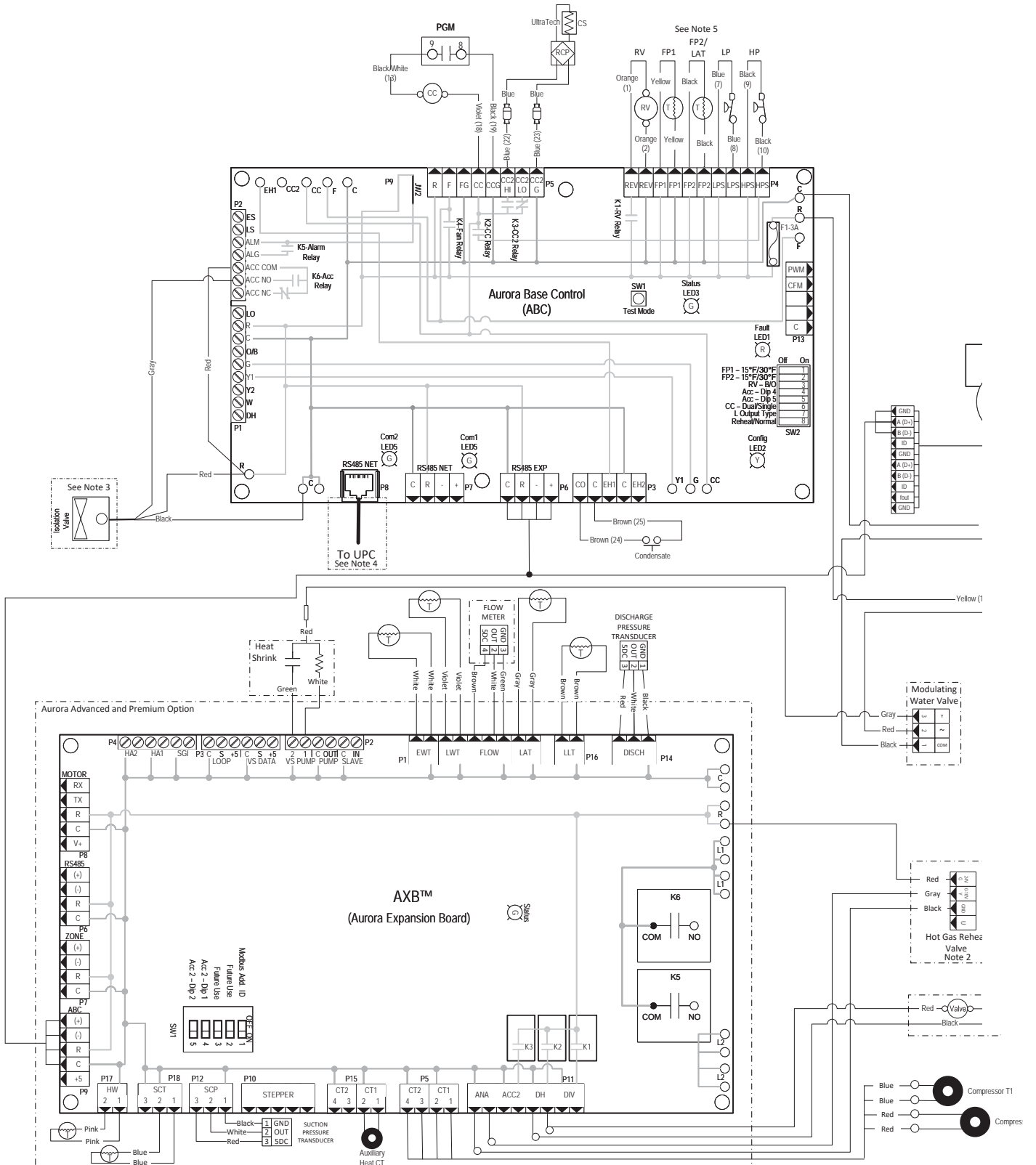

Wiring Schematics cont.

Single Compressor 575/60/3

97P895-08

07/27/22

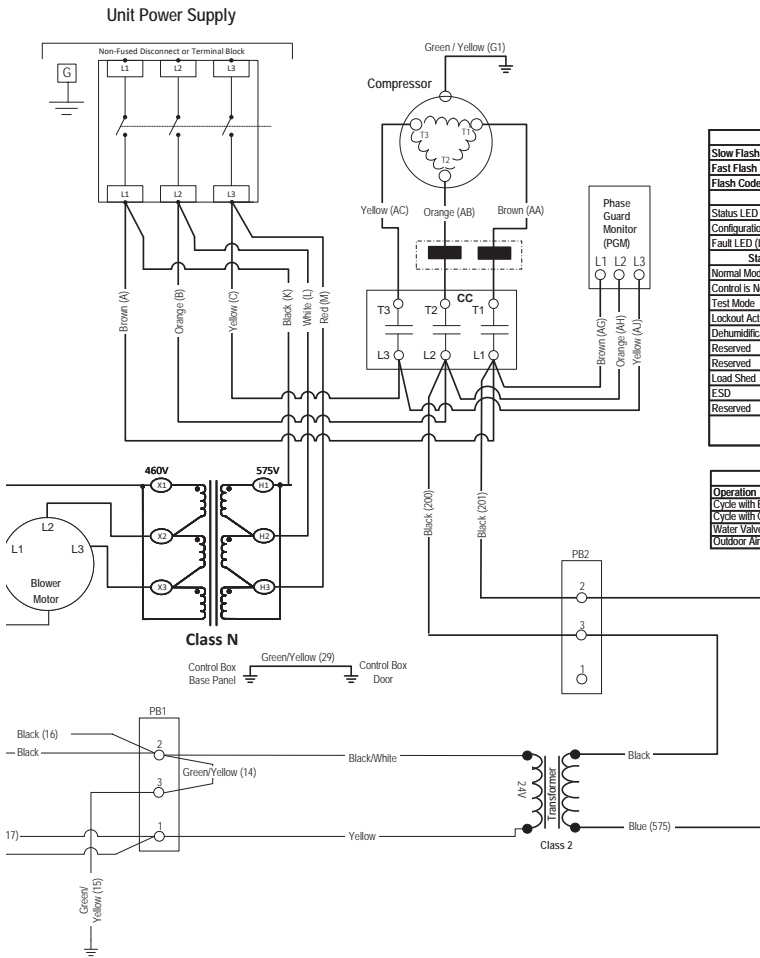

Aurora LED Flash Codes		
Slow Flash	1 second on and 1 second off	
Fast Flash	100 milliseconds on and 100 milliseconds off	
Flash Code	100 milliseconds on and 400 milliseconds off with a 2 second pause before repeating	
Random Start Delay		
Status LED (LED3, Green)	Fast Flash	
Configuration LED (LED2, Yellow)	Fast Flash	
Fault LED (LED1, Red)	Fast Flash	
Status LED (LED3, Green)	Configuration LED (LED2, Yellow)	Fault LED (LED1, Red)
Normal Mode	ON	No Software Override
Control is Non-Functional	OFF	Flash ECM Setting
Test Mode	Slow Flash	Normal Mode
Lockout Active	Fast Flash	DIP Switch Override
Dehumidification Mode	Flash Code 2	Input Fault Lockout
Reserved	Flash Code 3	High Pressure Lockout
Reserved	Flash Code 4	Flash Code 3
Load Shed	Flash Code 5	Low Air Coil Limit Lockout - FP2
ESD	Flash Code 6	Low Water Coil Limit Lockout - FP1
Reserved	Flash Code 7	Flash Code 4
		Loss of Charge Lockout
		Flash Code 5
		Flash Code 6
		Flash Code 7
		Flash Code 8
		Flash Code 9
		Flash Code 10
		Flash Code 11

Accessory Relay		
Operation	SM2-4	SM2-5
Cycle with Blower	On	On
Cycle with Compressor	Off	Off
Water Valve Slow Open	On	Off
Outdoor Air Damper	Off	On

Aurora Timing Events		
Event	Normal Mode	Test Mode
Random Start Delay	5 to 80 seconds	1 second
Compressor On Delay	5 seconds	< 1 second
Compressor Minimum On Time	2 minutes	5 seconds
Compressor Short Cycle Delay	4 minutes	15 seconds
Blower Off Delay	30 seconds	2 seconds
Fault Recognition Delay - High Pressure	Less than 1 second	Less than 1 second
Start-Up Bypass - Low Pressure	2 minutes	30 seconds
Fault Recognition Delay - Low Pressure	30 seconds	30 seconds
Start-Up Bypass - Low Water/Air Coil Limit	2 minutes	30 seconds
Fault Recognition Delay - Low Water/Air Coil Limit	30 seconds	30 seconds
Fault Recognition Delay - Condensate Overflow	30 seconds	30 seconds
Thermostat Call Recognition Time	2 seconds	2 seconds
Auxiliary Heat Staging Delay	5 minutes	20 seconds
Emergency Heat Staging Delay	2 minutes	7.5 seconds
Water Valve Slow Open Delay	90 seconds	90 seconds
Reheat Delay	30 seconds	30 seconds

Notes:

- 1 - P1 (screw terminals) and P9 (Molex connector) are adjacent and share common terminals in the same order.
- 2 - Optional factory installed hot gas reheat.
- 3 - Optional factory installed internal isolation valve.
- 4 - Optional UPC. See supplemental schematic for AXB and/or UPC connections.
- 5 - LAT location with Aurora Base Controls, FP2 with Aurora Advanced and Premium Controls.

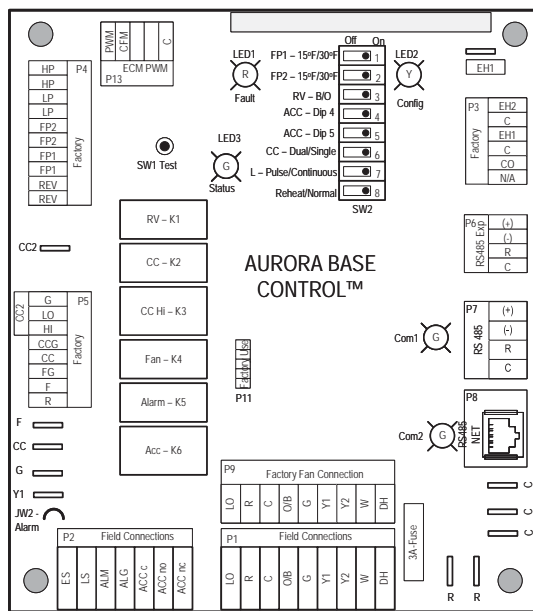

Legend

	Factory Low Voltage Wiring		Thermistor
	Factory Line Voltage Wiring		Relay Coil
	Field Low Voltage Wiring		Switch - Condensate Overflow
	Field Line Voltage Wiring		Switch - High pressure
	Optional Block		Switch - Low pressure
	DC Voltage PCB Traces		Polarized connector
	Field Zone, Sensor Wiring		Pin Number Designation on Twist-Lock Connector
	Internal Junction		Light Emitting Diode - Green
	Quick Connect Terminal		Light Emitting Diode - Yellow
	Field Wiring Lug		Light Emitting Diode - Red
	Ground		
	Relay Contacts - N.O., N.C.		
	Capacitor		
	Fuse		
	Current Transducer		

CC - Compressor Contactor
 CO - Condensate Overflow Sensor
 ES - Emergency Shutdown
 EWT - Entering Water Temp Sensor
 HP - High Pressure Switch
 LAT - Leaving Air Temp
 LLT - Liquid Line Temp
 LP - Low Pressure Switch
 LWT - Leaving Water Temp

FP1 - Freeze Protection Sensor 1
 FP2 - Freeze Protection Sensor 2
 RV - Reversing Valve Coil
 PGM - Phase Guard Monitor
 RH - Reheat Valve Coil

Wiring Schematics cont.

Dual Compressor Aurora Base 575/60/3

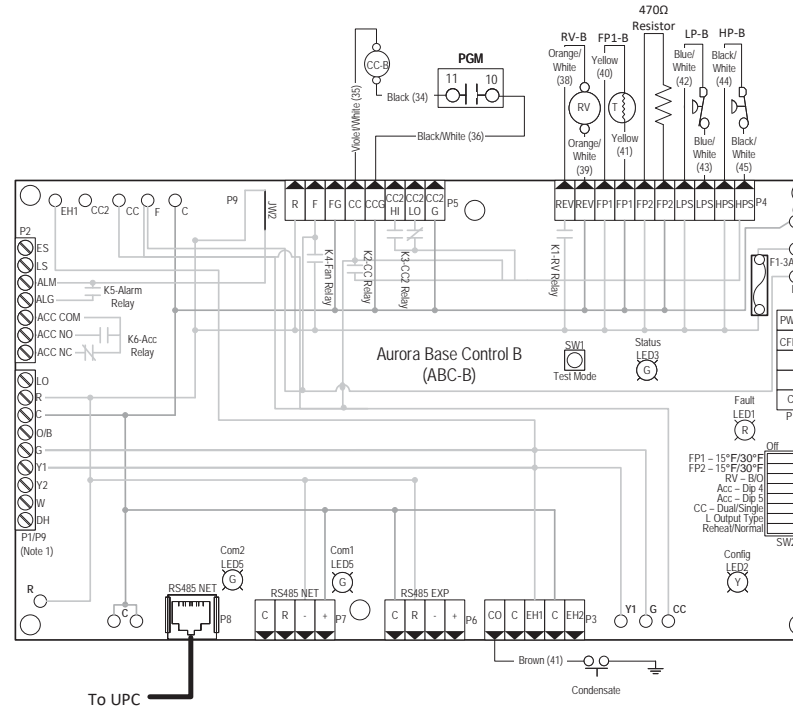
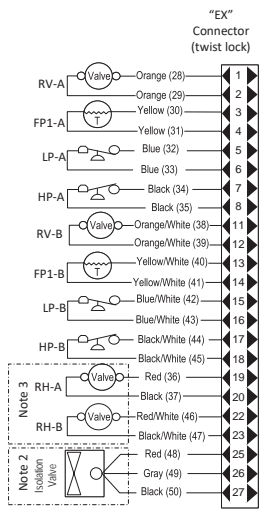
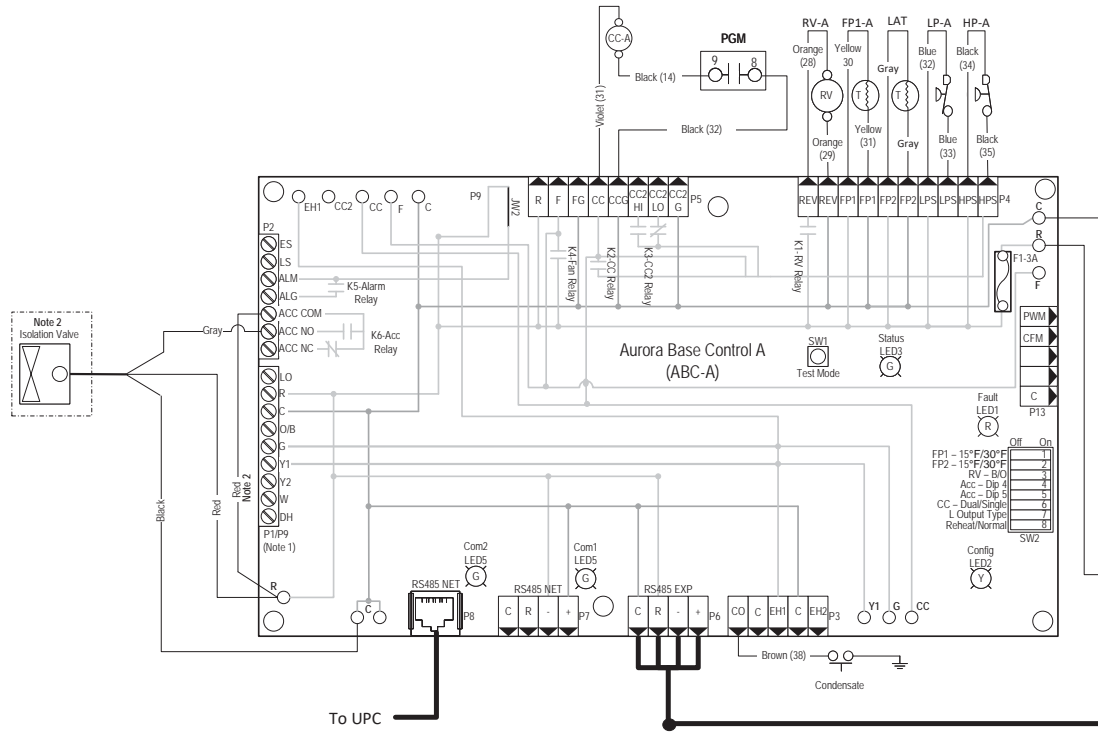

Wiring Schematics cont.

Dual Compressor Aurora Base 575/60/3

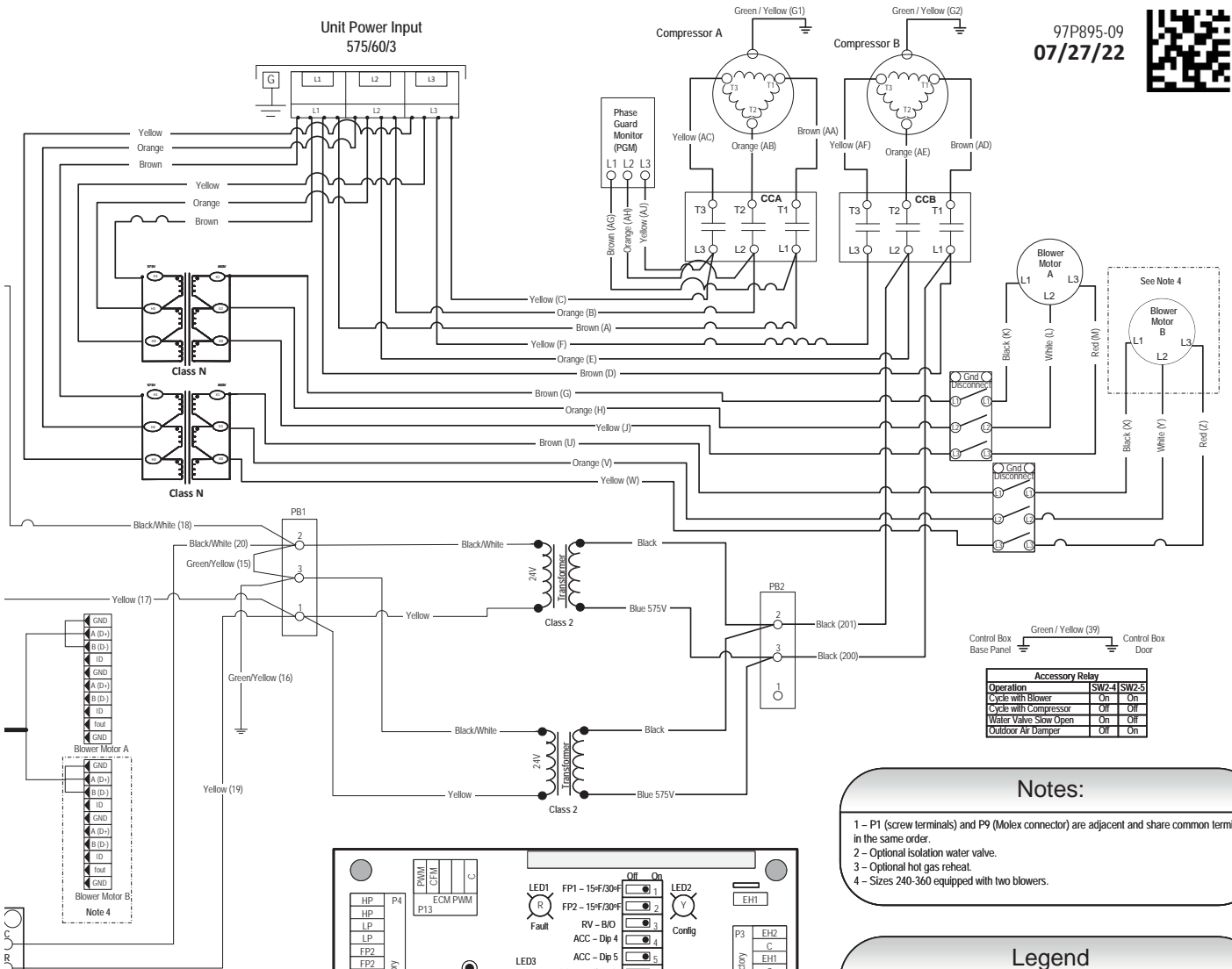

97P895-09
07/27/22



Accessory Relay		
Operation	SW2-4	SW2-5
Cycle with Blower	On	On
Cycle with Compressor	Off	Off
Water Valve Slow Open	On	Off
Outdoor Air Damper	Off	On

Notes:

- 1 - P1 (screw terminals) and P9 (Molex connector) are adjacent and share common terminals in the same order.
- 2 - Optional isolation water valve.
- 3 - Optional hot gas reheat.
- 4 - Sizes 240-360 equipped with two blowers.

Legend

	Factory Low Voltage Wiring		Thermistor
	Factory Line Voltage Wiring		Relay Coil
	Field Low Voltage Wiring		Switch - Condensate Overflow
	Field Line Voltage Wiring		Switch - High pressure
	Optional Block		Switch - Low pressure
	DC Voltage PCB Traces		Quick Connect Terminal
	Field Zone Sensor Wiring		Polarized connector
	Internal Junction		Pin Number Designation on Twist-Lock Connector
	Field Connections		Light Emitting Diode - Green
	Internal Junction		Light Emitting Diode - Yellow
	Quick Connect Terminal		Light Emitting Diode - Red

CCA - Compressor A Contactor
 CCB - Compressor B Contactor
 CO - Condensate Overflow Sensor
 ES - Emergency Shutdown
 HP1 - High Pressure Switch 1
 HP2 - High Pressure Switch 2
 LP1 - Low Pressure Switch 1
 LP2 - Low Pressure Switch 2
 FP1 - Freeze Protection Sensor 1
 FP2 - Freeze Protection Sensor 2
 F1 - Fuse

SW1 - Push button
 SW2 - DIP package 8 position
 RV1 - Reversing Valve Coil 1
 RV2 - Reversing Valve Coil 2
 PGM - Phase Guard Monitor
 RH - Reheat Valve Coil

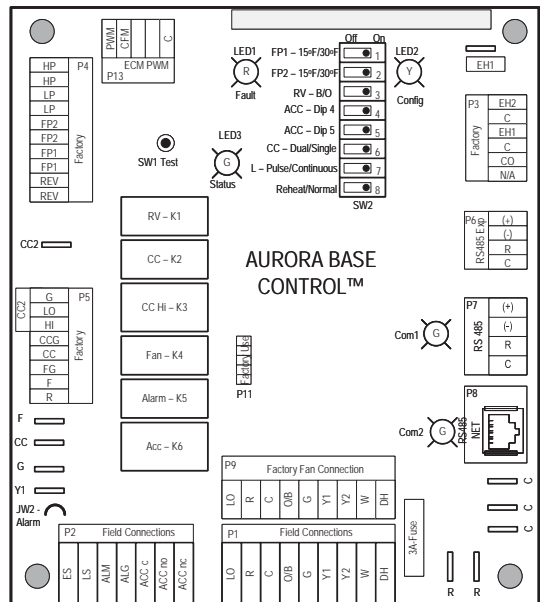

Wiring Schematics cont.

Dual Compressor Aurora Advanced and Premium 575/60/3

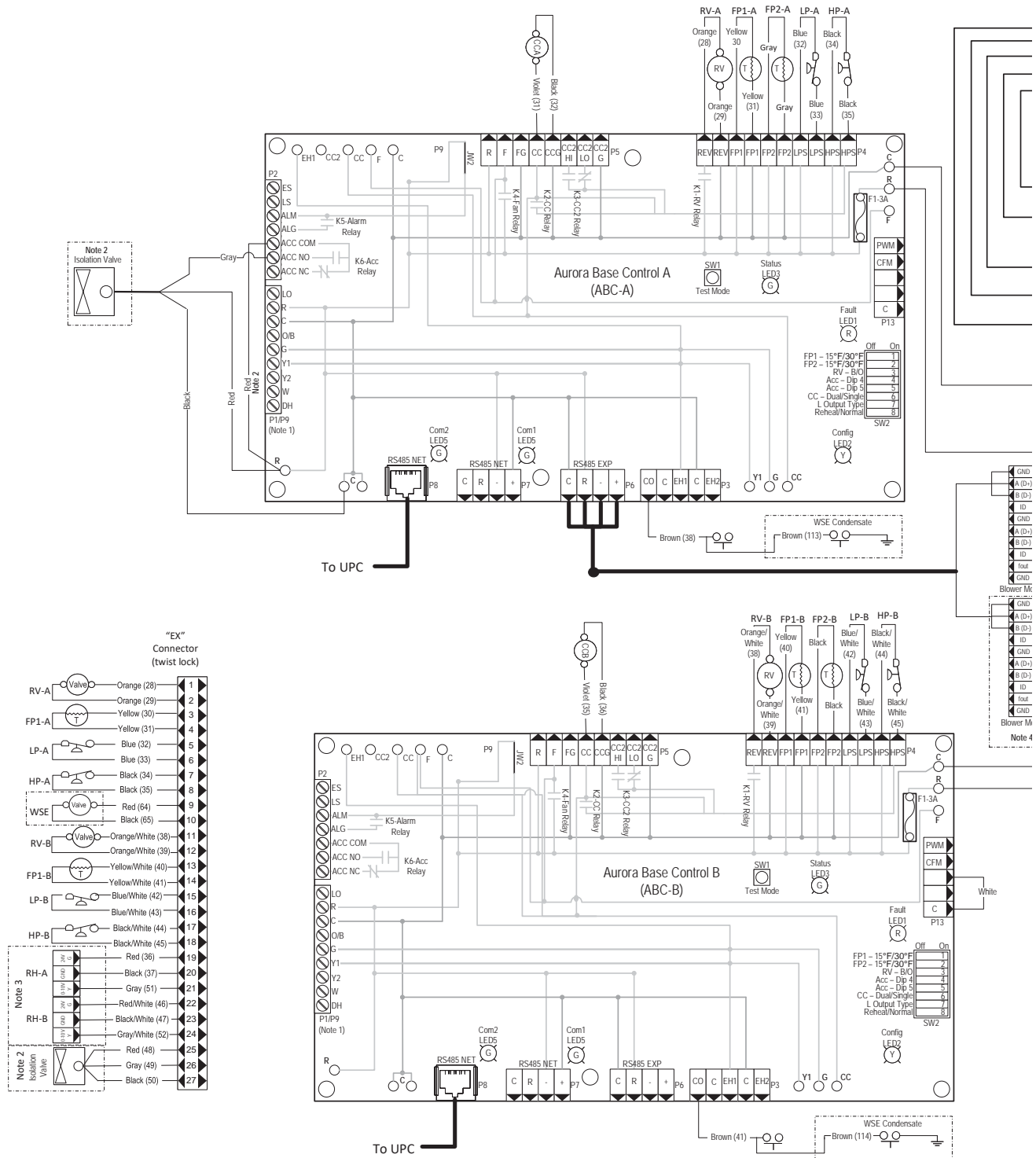

Wiring Schematics cont.

Dual Compressor Aurora Advanced and Premium 575/60/3

97P895-10
07/28/22

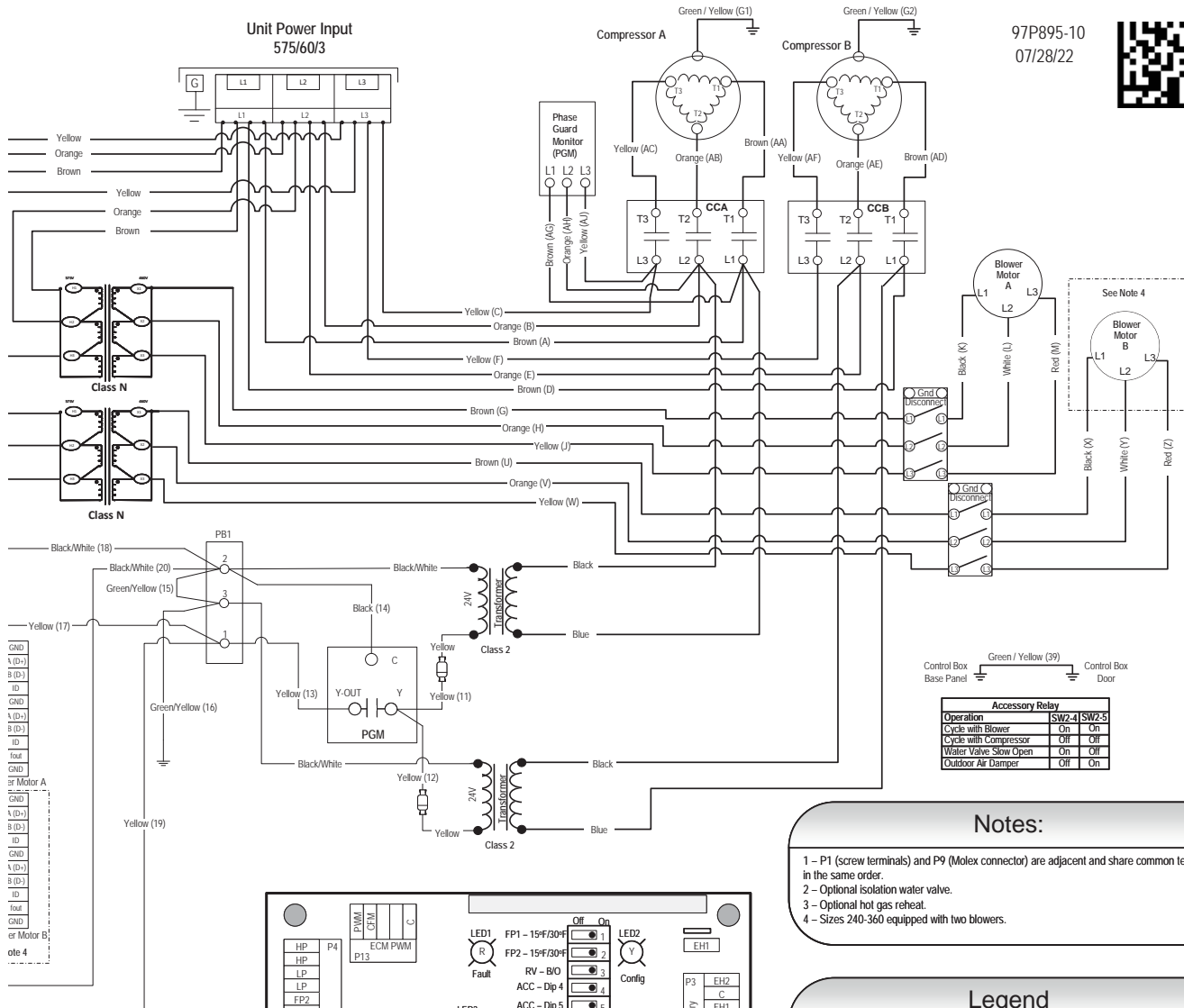

Accessory Relay		
Operation	SW2-4	SW2-5
Cycle with Blower	On	On
Cycle with Compressor	Off	Off
Water Valve Slow Open	On	Off
Outdoor Air Damper	Off	On

Notes:

- 1 - P1 (screw terminals) and P9 (Molex connector) are adjacent and share common terminals in the same order.
- 2 - Optional isolation water valve.
- 3 - Optional hot gas reheat.
- 4 - Sizes 240-360 equipped with two blowers.

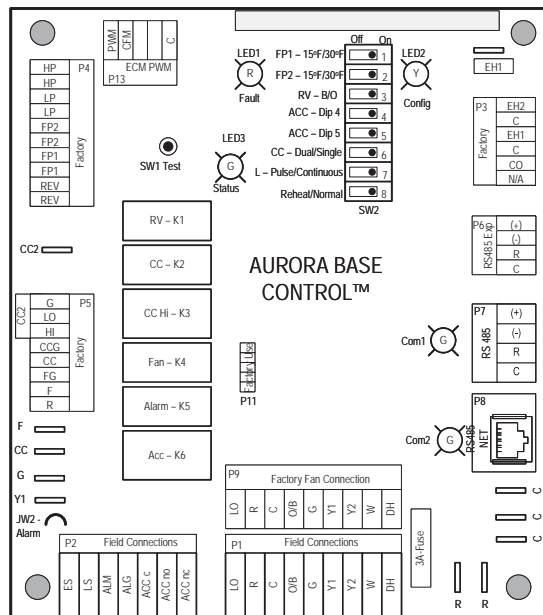

Legend

	Factory Low Voltage Wiring		Thermistor
	Factory Line Voltage Wiring		Relay Coil
	Field Low Voltage Wiring		Switch - Condensate Overflow
	Field Line Voltage Wiring		Switch - High pressure
	Optional Block		Switch - Low pressure
	DC Voltage PCB Traces		Polarized connector
	Field Zone Sensor Wiring		Pin Number Designation on Twist-Lock Connector
	Internal Junction		Light Emitting Diode - Green
	Quick Connect Terminal		Light Emitting Diode - Yellow
	Field Wiring Lug		Light Emitting Diode - Red
	Ground		SW1 - Push button
	Relay Contacts - N.O., N.C.		SW2 - DIP package 8 position
	Capacitor		RV1 - Reversing Valve Coil 1
	Fuse		RV2 - Reversing Valve Coil 2
	Current Transducer		PGM - Phase Guard Monitor
			RH - Reheat Valve Coil

CCA - Compressor A Contactor
 CCB - Compressor B Contactor
 CO - Condensate Overflow Sensor
 ES - Emergency Shutdown
 HP1 - High Pressure Switch 1
 HP2 - High Pressure Switch 2
 LP1 - Low Pressure Switch 1
 LP2 - Low Pressure Switch 2
 FP1 - Freeze Protection Sensor 1
 FP2 - Freeze Protection Sensor 2
 F1 - Fuse

Wiring Schematics cont.

084-300 Single/Dual Compressor Aurora UPC

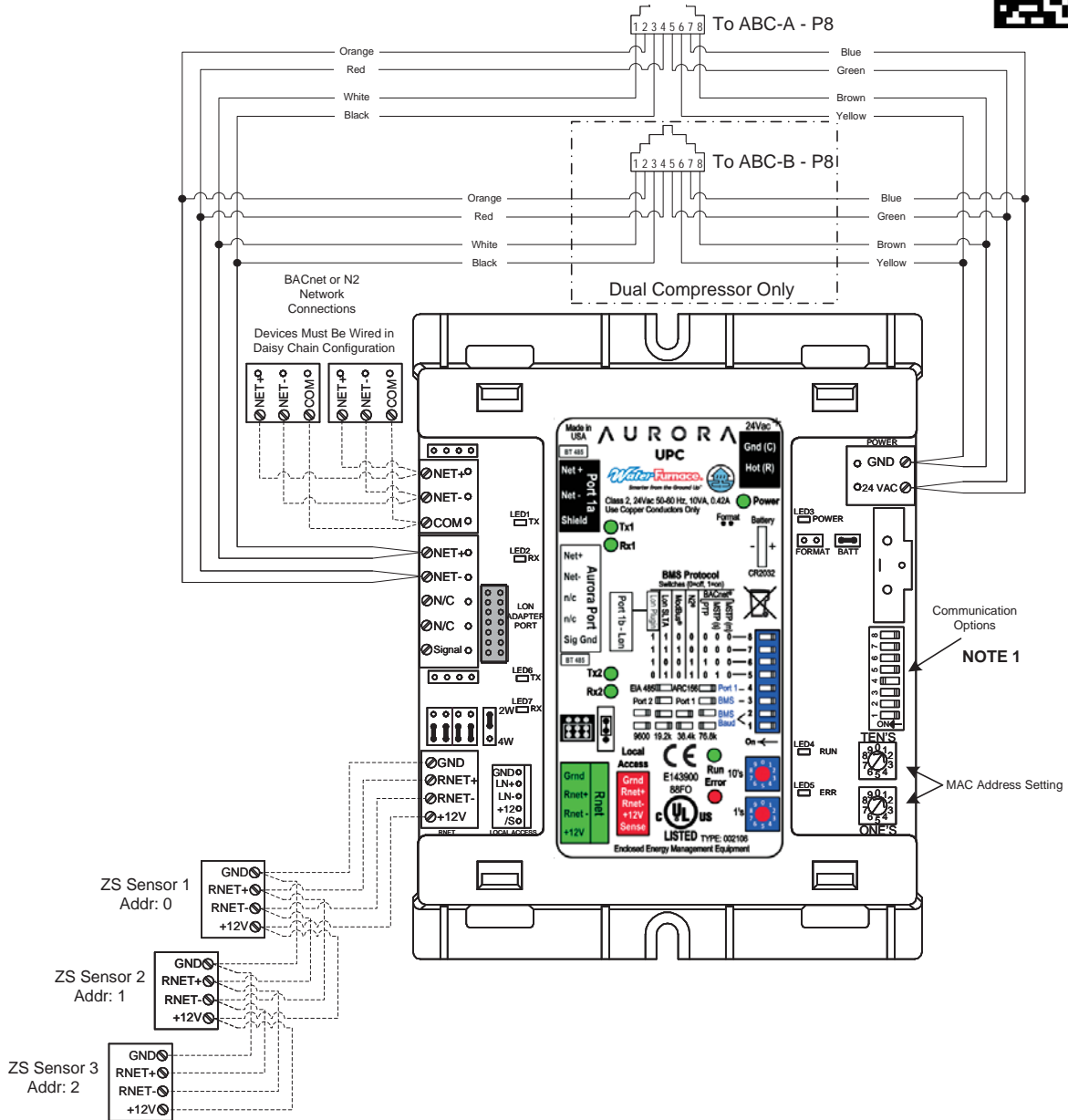

ZS Sensor Information

Zone Sensors can be wired in daisy chain as show or in a star or hybrid configuration. Maximum of 5 sensors per UPC. Maximum allowable load 210mA. See the UPC install manual for possible sensor combinations.

DIP Switch Value	NO
1	NO
2	NO
4	NO
8	NO

Each ZS sensor must have a unique address, but the addresses do not need to be sequential. Use the DIP switches on the back of the ZS sensor to set an address from 0 to 4. (0 is the factory default.) Each DIP switch has the value shown in the figure to the left. Turn on as many DIP switches as you need so that their total value equals the address.

Notes

1. Use DIP Switches 5 – 8 to change communication protocol and DIP switches 1 – 2 to change BACnet baud rate.
2. DDC functionality available where specifically indicated in the product controls options.



Legend

- Factory Low Voltage Wiring
- - - Field Low Voltage Wiring
- RJ45 Connector

Aurora Controls

Aurora Controls

The Aurora Control System is a complete commercial comfort system that can bring all aspects of the HVAC system into one cohesive module network. The Aurora System is available in two configurations: Aurora Base Control and Aurora Advanced and Aurora Premium Control both with optional Aurora UPC for DDC applications.

Control	General Description	Application	Display/Interface	Protocol
<p>Aurora Base Control</p> 	<p>The ABC microprocessor provides all the features necessary to operate today's standard WSHPs that utilize dual capacity compressors and variable speed ECM/5 speed ECM blower motors with hot gas reheat. This control can communicate to a handheld diagnostic tool to help the installing contractor or service technician with equipment setup and service. By utilizing Modbus RTU communication protocol, the ABC board can communicate with additional devices on the Aurora network</p>	<p>Used for residential and commercial applications that use single or dual capacity compressors with PSC, 5-speed ECM, or variable speed ECM blower motors. This base control can also communicate to the AID Tool to display faults, inputs/outputs, and software revision. Commercial features such as hot gas reheat, slow opening water valve, and random start are also capable with the ABC board.</p>	<p>Optional AID tool can be used for field service.</p>	<p>Standalone</p>
<p>Aurora Advanced and Premium</p> 	<p>Aurora Advanced Control adds the Aurora AXB expansion board and provides added I/O and standard features such as refrigerant, performance or energy monitoring.</p>	<ul style="list-style-type: none"> • Refrigeration Monitoring – provides Suction and discharge pressure, Suction, liquid line temps and superheat and subcooling. • Performance Monitoring – provides entering and leaving loop water temperatures, loop flow rate as well as heat of extraction or rejection rate into the loop. • Energy Monitoring – provides real-time power measurement (Watt) of compressor, fan, auxiliary heat and zone pump. • Plus many more I/O options 	<p>Optional AID tool can be used for field service.</p>	<p>Standalone</p>
<p>Aurora Base/ Aurora Advanced Control w/UPC BACnet or N2</p> 	<p>The Aurora Unitary Protocol Converter (UPC) is an integrated solution and communicates directly with the Aurora Heat Pump Controls and allows access/control of a variety of internal Aurora heat pump operations such as sensors, relay operation, faults and other information. In turn, the UPC then converts internal Aurora Modbus protocol to BACnet MS/TP, or N2 protocols and communicates to the BAS system. This provides the great benefit of complete control integration and a myriad of information available to the BAS from the heat pump control. Plus it also allows individual unit configuration such as ECM fan speeds or freeze protection setting directly over the BAS without the need for access to the actual heat pump.</p>	<p>The Aurora UPC is implemented with the Aurora heat pump control into our latest water source heat pumps. All Internal Aurora points are accessible to the UPC via firmware providing an integrated solution. All zone temperatures and zone sensors are connected to the UPC on an RNet bus, simplifying hook up at the unit. RNet sensors can include a combination of zone temperature and humidity, CO2, and VOC sensors. The UPC includes built-in support for a custom configurable keypad/display unit.</p>	<p>Optional Aurora Touch</p>	<p>BACnet MS/TP or N2 Open (DIP selectable)</p>

Aurora Controls cont.

Aurora 'Base' Control



NOTE: Refer to the Aurora Base Control Application and Troubleshooting Guide and the Instruction Guide: Aurora Interface and Diagnostics (AID) Tool for additional information.

The **Aurora Base Control** provides all baseline operation of 7 faults (HP, LP and LOC, coax freeze protection, air coil Freeze protection, over/under Voltage and condensate overflow), as well as compressor and fan speed and lockout management through the single ABC board (Aurora Base Control). The control features all heat pump operational timings, configurations, sensors and fault history that can be viewed using then AID tool.

Optional Aurora UPC

When coupled with the optional Aurora UPC, the system can communicate all of these same heat pump parameters to the BAS as network points using either BACnet or N2. This means that not only are heat pump parameters visible by the BAS, many configuration settings, such as airflow and freeze detection settings, can also be changed from the BAS system saving commissioning costs. This provides both cost advantages and features not typically found on WSHP controls. All configuration, sensor and servicing can be accessed thru the AuroraTouch color service tool. This integration allows heat pump monitoring sensors, status and service diagnosis faults to be communicated thru the DDC direct to the building automation system (BAS), giving building supervisors detailed and accurate information on every piece of equipment without removing an access panel!

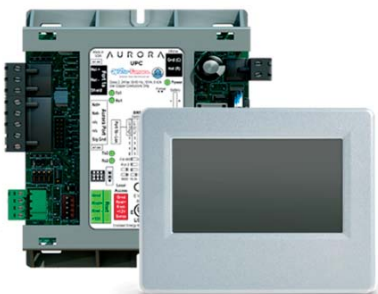

Control Features

Software ABC Standard Version 3.0

Single or Dual Capacity Compressors

Either single or dual capacity compressors can be operated.

Variable Speed ECM

Blower Motor Option (If Applicable)

A Variable Speed ECM blower motor can be driven directly using the onboard PWM output. Four blower speeds are available based upon the G, Y1, Y2, and W input signals to the board. The blower speeds can be changed either by the ECM manual configurations mode method or by using the Aurora AID Tool directly. All four blower speeds can be set to the same speed if desired.

5-Speed ECM Blower Motor Option (If Applicable)

A 5-Speed ECM blower motor will be driven directly using the thermostat connections. Any of the G, Y1, or Y2/W signals can drive any of the 5 available pre-programmed blower speeds on the motor.

Other Control Features

- Random start at power up
- Anti-short cycle protection
- High and low pressure cutouts
- Loss of charge
- Water coil freeze detection
- Air coil freeze detection
- Over/under voltage protection
- Condensate overflow sensor
- Load shed
- Dehumidification (where applicable)
- Emergency shutdown
- Hot gas reheat operation (where applicable)
- Diagnostic LED
- Test mode push button switch
- Two auxiliary electric heat outputs
- Alarm output
- Accessory output with N.O. and N.C.
- Modbus communication (master)
- Modbus communication (slave)

Aurora Controls cont.

Field Selectable Options via Hardware

DIP Switch (SW1) - Test/Configuration Button (See SW1 Operation Table)

Test Mode

The control is placed in the test mode by holding the push button switch SW1 for 2 - 5 seconds. In test mode most of the control timings will be shortened by a factor of sixteen (16). LED3 (green) will flash at 1 second on and 1 second off. Additionally, when entering test mode LED1 (red) will flash the last lockout one time. Test mode will automatically time out after 30 minutes. Test mode can be exited by pressing and holding the SW1 button for 2 to 5 seconds or by cycling the power. **NOTE:** Test mode will automatically be exited after 30 minutes.

Variable Speed ECM Configuration Mode (If Applicable)

The control is placed in the ECM configuration mode by holding the pushbutton switch SW1 for 5 to 10 seconds, the high, low, and "G" ECM speeds can be selected by following the LED display lights. LED2 (yellow) will fast flash when entering the ECM configuration. When setting "G" speed LED3 (green) will be continuously lit, for low speed LED1 (red) will be continuously lit, and for high speed both LED3 (green) and LED1 (red) will be continuously lit. During the ECM configuration mode LED2 (yellow) will flash each of the 12 possible blower speeds 3 times. When the desired speed is flashed press SW1, LED2 will fast flash until SW1 is released. "G" speed has now been selected. Next select low speed, and high speed blower selections following the same process above. After third selection has been made, the control will exit the ECM configuration mode. Aux fan speed will remain at default or current setting and requires the AID Tool for adjustment.

Reset Configuration Mode

The control is placed in reset configuration mode by holding the push button switch SW1 for 50 to 60 seconds. This will reset all configuration settings and the EEPROM back to the factory default settings. LED3 (green) will turn off when entering reset configuration mode. Once LED3 (green) turns off, release SW1 and the control will reset.

DIP Switch (SW2)

- SW2-1** FP1 Selection - Low water coil temperature limit setting for freeze detection. On = 30°F; Off = 15°F.
- SW2-2** FP2 Selection - On = 30°F; Off = N/A
- SW2-3** RV - O/B - thermostat type. Heat pump thermostats with "O" output in cooling or "B" output in Heating can be selected. On = O; Off = B.
- SW2-4** Access Relay Operation (P2) and 2-5

Access Relay Operation	SW2-4	SW2-5
Cycle with Blower	ON	ON
Cycle with Compressor	OFF	OFF
Water Valve Slow Opening	ON	OFF
Cycle with Comm. T-stat Hum Cmd	OFF	ON

Cycle with Blower - The accessory relay will cycle with the blower output.

Cycle with Compressor - The accessory relay will cycle with the compressor output.

Water Valve Slow Opening - The accessory relay will cycle and delay both the blower and compressor output for 90 seconds.

- SW2-6** CC Operation - selection of single or dual capacity compressor. On = Single Stage; Off = Dual Capacity
- SW2-7** Lockout and Alarm Outputs (P2) - selection of a continuous or pulsed output for both the LO and ALM Outputs. On = Continuous; Off = Pulsed
- SW2-8** Future Use

Alarm Jumper Clip Selection

From the factory, ALM is connected to 24 VAC via JW2. By cutting JW2, ALM becomes a dry contact connected to ALG.

Variable Speed ECM Blower Speeds

The blower speeds can be changed either by using the ECM manual configurations mode method or by using the Aurora AID Tool directly (see Instruction Guide: Aurora Interface and Diagnostics (AID) Tool topic).

Aurora Controls cont.

Field Selectable Options via Software

(Selectable via the Aurora AID Tool)

ECM Blower Speeds

An ECM blower motor can be driven directly using the onboard PWM output. Four blower speeds are available, based upon the “G”, Y1 (low), Y2 (high), and Aux input signals to the board. The blower speeds can be changed either by the ECM manual configurations mode method (see ECM Configuration Mode topic) or by using the Aurora AID Tool directly. All four blower speeds can be set to the same speed if desired. Aux blower speed will remain at default or current setting and requires the AID Tool for adjustment.

Safety Features

The following safety features are provided to protect the compressor, heat exchangers, wiring and other components from damage caused by operation outside of design conditions.

Fuse - a 3 amp automotive type plug-in fuse provides protection against short circuit or overload conditions.

Anti-Short Cycle Protection - 4 minute anti-short cycle protection for the compressor.

Random Start - 5 to 80 second random start upon power up.

Fault Retry - in the fault condition, the control will stage off the outputs and then “try again” to satisfy the thermostat Y input call. Once the thermostat input calls are satisfied, the control will continue on as if no fault occurred. If 3 consecutive faults occur without satisfying the thermostat Y input call, then the control will go to Lockout mode.

Lockout - when locked out, the blower will operate continuously in “G” speed, and PSC blower motor output will remain on. The Alarm output (ALM) and Lockout output (L) will be turned on. The fault type identification display LED1 (Red) shall flash the fault code. To reset lockout conditions with SW2-8 On, thermostat inputs “Y1”, “Y2”, and “W” must be removed for at least 3 seconds. To reset lockout conditions with SW2-8 Off, thermostat inputs “Y1”, “Y2”, “W”, and “DH” must be removed for at least 3 seconds. Lockout may also be reset by turning power off for at least 30 seconds or by enabling the emergency shutdown input for at least 3 seconds.

Lockout With Emergency Heat - if the control is locked out in the heating mode, and a Y2 or W input is received, the control will operate in the emergency heat mode while the compressor is locked out. The first emergency heat output will be energized 10 seconds after the W input is received, and the blower will shift to high speed. If the control remains locked out, and the W input is present, additional stage of emergency heat will stage on after 2 minutes. When the W input is

removed, all of the emergency heat outputs will turn off, and the ECM blower will shift to “G” speed and PSC blower motor output will remain on.

High Pressure - fault is recognized when the Normally Closed High Pressure Switch, P4-9/10 opens, no matter how momentarily. The High Pressure Switch is electrically in series with the Compressor Contactor and serves as a hard-wired limit switch if an overpressure condition should occur.

Low Pressure - fault is recognized when the Normally Closed Low Pressure Switch, P4-7/8 is continuously open for 30 seconds. Closure of the LPS any time during the 30 second recognition time restarts the 30 second continuous open requirement. A continuously open LPS shall not be recognized during the 2 minute startup bypass time.

Loss of Charge - fault is recognized when the Normally Closed Low Pressure Switch, P4-7/8 is open prior to the compressor starting.

Condensate Overflow - fault is recognized when the impedance between this line and 24 VAC common or chassis ground drops below 100K ohms for 30 seconds continuously.

Freeze Detection (Coax) - set points shall be either 30°F or 15°F. When the thermistor temperature drops below the selected set point, the control shall begin counting down the 30 seconds delay. If the thermistor value rises above the selected set point, then the count should reset. The resistance value must remain below the selected set point for the entire length of the appropriate delay to be recognized as a fault. This fault will be ignored for the initial 2 minutes of the compressor run time.

Freeze Detection (Air Coil) - uses the FP2 input to protect against ice formation on the air coil. The FP2 input will operate exactly like FP1 except that the set point is 30 degrees and is not field adjustable.

Over/Under Voltage Shutdown - An over/under voltage condition exists when the control voltage is outside the range of 18 VAC to 30 VAC. If the over/under voltage shutdown lasts for 15 minutes, the lockout and alarm relay will be energized. Over/under voltage shutdown is self-resetting in that if the voltage comes back within range of 18 VAC to 30 VAC for at least 0.5 seconds, then normal operation is restored.

Aurora Controls cont.

Operation Description

Power Up - The unit will not operate until all the inputs and safety controls are checked for normal conditions. The unit has a 5 to 80 second random start delay at power up. Then the compressor has a 4 minute anti-short cycle delay after the random start delay.

Standby In standby mode, Y1, Y2, W, DH, and G are not active. Input O may be active. The blower and compressor will be off.

Heating Operation

Single Compressor Heating, 2nd Stage (Y1, Y2)

The compressor will be staged to full capacity 20 seconds after Y2 input is received. The ECM blower will shift to high speed seconds after the Y2 input is received.

Dual Compressor Heating, 2nd Stage (Y1, Y2)

In dual compressor operation, two ABC boards used in 24 VAC operation, there will be a Y2 call to the Y1 input on the second ABC. The compressor will stage to full capacity 30 seconds after Y1 input is received to the second board.

Single Compressor Heating, 3rd Stage (Y1, Y2, W)

The hot water pump is de-energized and the first stage of electric heat is energized 10 seconds after the W command is received. If the demand continues the second stage of electric heat will be energized after 5 minutes.

Dual Compressor Heating, 3rd Stage (Y1, Y2, W) -

The first stage of electric heat is energized 10 seconds after the W command is received. If the demand continues the second stage of electric heat will be energized after 5 minutes

Emergency Heat (W) - The blower will be started on "G" speed, 10 seconds later the first stage of electric heat will be turned on. 5 seconds after the first stage of electric heat is energized the blower will shift to Aux speed. If the emergency heat demand is not satisfied after 2 minutes the second electric heat stage will be energized.

Blower (G) - The blower will start immediately upon receiving a thermostat G command. If there are no other commands from the thermostat the ECM will run on "G" speed until the G command is removed. Regardless of blower input (G) from the thermostat, the blower will remain on for 30 seconds at the end of each heating cycle.

Cooling Operation

In all cooling operations, the reversing valve directly tracks the O input. Thus, anytime the O input is present, the reversing valve will be energized.

Single Compressor Cooling, 2nd Stage (Y1, Y2, O)

The compressor will be staged to full capacity 20 seconds after Y2 input was received. The ECM blower will shift to high speed 15 seconds after the Y2 input was received.

Dual Compressor Cooling, 2nd Stage (Y1, Y2, O)

In dual compressor operation, two ABC boards used in 24 VAC operation, there will be a Y2 call to the Y1 input on the second ABC. The compressor will stage to full capacity 30 seconds after Y1 input is received to the second board.

Blower (G) - The blower will start immediately upon receiving a thermostat G command. If there are no other commands from the thermostat the ECM will run on "G" speed until the G command is removed. Regardless of blower input (G) from the thermostat, the blower will remain on for 30 seconds at the end of each heating, cooling, and emergency heat cycle.

Dehumidification (Y1, O, DH or Y1, Y2, O, DH) - When a DH command is received from the thermostat during a compressor call for cooling the ECM blower speed will be reduced by 15% to increase dehumidification.

Emergency Shutdown - Four (4) seconds after a valid ES input, P2-7 is present, all control outputs will be turned off and remain off until the emergency shutdown input is no longer present. The first time that the compressor is started after the control exits the emergency shutdown mode, there will be an anti-short cycle delay followed by a random start delay. Input must be tied to common to activate.

Continuous Blower Operation - The blower output will be energized any time the control has a G input present, unless the control has an emergency shutdown input present. The blower output will be turned off when G input is removed.

Load Shed - The LS input disables all outputs with the exception of the blower output. When the LS input has been cleared, the anti-short cycle timer and random start timer will be initiated. Input must be tied to common to activate.

Aurora Controls cont.

Aurora 'Base' Control LED Displays

These three LEDs display the status, configuration, and fault codes for the control. These can also be read in plain English via the Aurora AID Tool.

Status LED (LED3, Green)

Description of Operation	Fault LED, Green
Normal Mode	ON
Control is Non-functional	OFF
Test Mode	Slow Flash
Lockout Active	Fast Flash
Dehumidification Mode (Future Use)	Flash Code 2
(Future Use)	Flash Code 3
(Future Use)	Flash Code 4
Load Shed	Flash Code 5
ESD	Flash Code 6
(Future Use)	Flash Code 7

Configuration LED (LED2, Yellow)

Description of Operation	Configuration LED, Yellow
No Software Overwritten	Flashing ECM Setting
DIP Switch was Overwritten	Slow Flash
ECM Configuration Mode	Fast Flash

Fault LED (LED1, Red)

Red Fault LED		LED Flash Code*	Lockout	Reset/Remove
ABC Basic Faults	Normal - No Faults	OFF	-	
	Fault - Input	1	No	Auto
	Fault - High Pressure	2	Yes	Hard or Soft
	Fault - Low Pressure	3	Yes	Hard or Soft
	Fault - Freeze Detection FP2	4	Yes	Hard or Soft
	Fault - Freeze Detection FP1	5	Yes	Hard or Soft
	Fault - Condensate Overflow	7	Yes	Hard or Soft
	Fault - Over/Under Voltage	8	No	Auto
	Fault - FP1 & FP2 Sensor Error	11	Yes	Hard or Soft

NOTE: All codes >11 use long flash for tens digit and short flash for the ones digit. 20, 30, 40, 50, etc. are skipped.

Aurora Interface and Diagnostics (AID) Tool

The Aurora Interface and Diagnostics (AID) Tool is a device that is a member of the Aurora network. The AID Tool is used to troubleshoot equipment which uses the Aurora control via Modbus RTU communication. The AID Tool provides diagnostics, fault management, ECM setup, and system configuration capabilities to the Aurora family of controls. An AID Tool is recommended, although not required, for ECM airflow settings. The AID Tool simply plugs into the ABC-A board.



ABC Control Board Layout

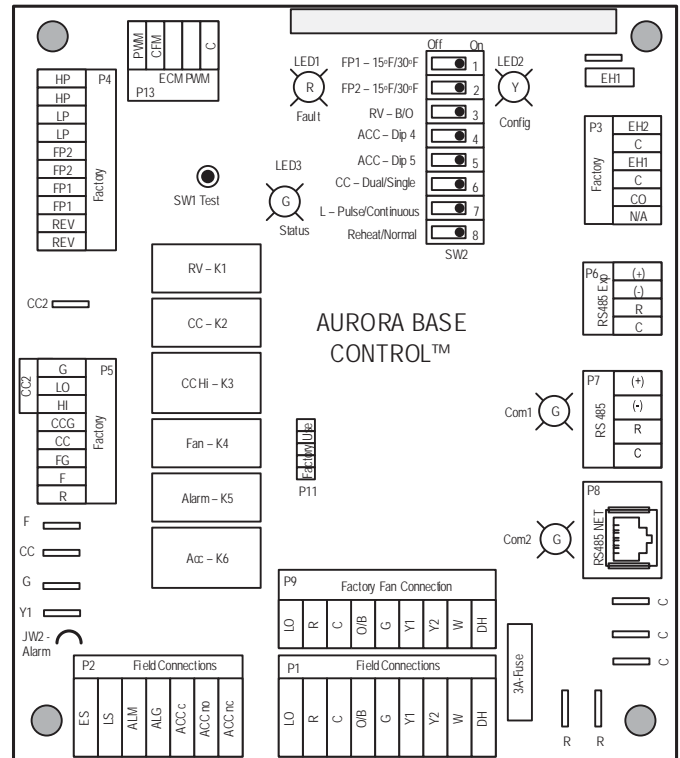

Aurora Controls cont.

Aurora Advanced and Aurora Premium Controls



The **Aurora Advanced and Aurora Premium Control** provides all of the Aurora Base Control features plus it adds the extended I/O of the Aurora Expansion Board (AXB) to the mix. This extended I/O includes the energy monitoring where current transducers measure current and power of fan and compressor. Aurora Premium Controls add refrigeration monitoring kit that reports refrigerant temperatures and pressures and will calculate superheat and subcooling. The Premium package also includes performance kit for entering and leaving water temperature along with source water flow rate via optional field installed flow meter.

Optional Aurora UPC

When coupled with the optional Aurora UPC, can communicate all of these same heat pump parameters to the BAS as network points using either BACnet MS/TP or N2 protocols. This means that not only are heat pump parameters visible by the BAS, many configuration settings, such as airflow and freeze detection settings, can also be changed from the BAS system saving commissioning costs. All configuration, sensor and servicing can be accessed through the AuroraTouch color service tool. With the optional Advanced controls and the monitoring kits installed refrigeration, performance and energy consumption are all cost effectively transmitted to the BAS!

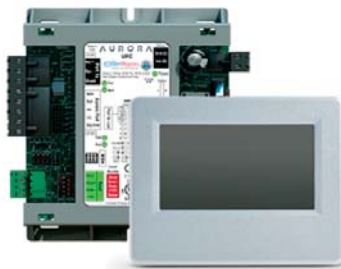

Aurora Advanced And Aurora Premium Control Features

The Aurora 'Advanced' Control system expands on the capability of the Aurora 'Base' Control (ABC) by adding the Aurora Expansion Board (AXB). All of the preceding features of the Aurora 'Base' Control are included. The following control description is of the additional features and capability of the Aurora advanced control.

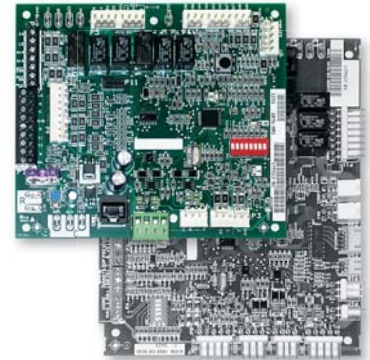

It is highly recommended the installing/servicing contractor obtain an Aurora Interface and Diagnostic Tool (AID) and specialized training before attempting to install or service an Aurora 'Advanced' control system.

The additional AXB features include the following:

Leaving Air Temperature Sensor

Standard on all Aurora Advanced Controls is a leaving air (discharge air) sensor. This sensor is pre-mounted for downflow applications and will need to be repositioned for side discharge applications in a high velocity location for best results

AXB DIP Switch

DIP 1 - ID: This is the AXB ModBus ID and should always read On.

DIP 2 & 3 - Future Use

DIP 4 & 5 - Accessory Relay2: A second, DIP configurable, accessory relay is provided that can be cycled with the compressor 1 or 2, blower, or the Dehumidifier (DH) input. This is to complement the Accessory 1 Relay on the ABC board.

Position	DIP 4	DIP 5	Description
1	ON	ON	Cycles with Fan or ECM (or G)
2	OFF	ON	Cycles with CC1 first stage of compressor or compressor spd 1-6
3	ON	OFF	Cycles with CC2 second stage of compressor or compressor spd 7-12
4	OFF	OFF	Cycles with DH input from ABC board

Compressor Monitoring

The AXB includes two current transducers to monitor the compressor current and starting characteristics. Open circuits or welded contactor faults will be detected. This fault will produce an E10 code.

Aurora Controls cont.

Variable Speed Pump

This input and output are provided to drive and monitor a variable speed pump. The VS pump output is a PWM signal to drive the variable speed pump. The minimum and maximum level are set using the AID Tool. 75% and 100% are the default settings respectively. The VS data input allows a separate PWM signal to return from the pump giving fault and performance information. Fault received from the variable speed pump will be displayed as E16. Consult factory for application assistance.

Modulating Water Valve

This output is provided to drive a modulating water valve. Through advanced design the 0-10VDC valve can be driven directly from the VS pump output. The minimum and maximum level are set in the same way as the VS pump using the AID Tool. 75% and 100% are the default settings respectively.

Advanced Communication Ports

Communication ports P6 and P8 will provide future expansion via dedicated protocols. These are for future use.

Monitoring Sensor Kits

Energy Monitoring (Standard Sensor Kit on 'Advanced' models)

The Energy Monitoring Kit includes two current transducers (blower and electric heat) added to the existing two compressor sensors so that the complete power usage of the heat pump can be measured. The AID Tool provides configuration detail for the type of blower motor, power adjustment and a line voltage calibration procedure to improve the accuracy, and a power adjustment setting that allows the compressor power to be adjusted to match the unit's line voltage using the provided tables. This information can be displayed on the AID Tool or selected communicating thermostats. The TPCM32U03A/04A will display instantaneous energy use while the color touchscreen TPCC32U01 will in addition display a 13 month history in graph form. Refer to Unit Start Up Energy Monitoring for configuration details.

Refrigerant Monitoring (Standard with Premium Controls)

Refrigerant Monitoring Kit includes two pressure transducers, and three temperature sensors, heating liquid line, suction temperature and existing cooling liquid line (FP1). These sensors allow the measurement of discharge and suction pressures, suction and liquid line temperatures as well as superheat and subcooling. This information will only be displayed on the AID Tool.

Performance Monitoring (Standard with Premium Controls)

Performance Monitoring Kit includes three temperature sensors, entering and leaving water, leaving air temperature and a water flow rate sensor. With this kit heat of extraction and rejection will be calculated. This requires configuration using the AID Tool for selection of water or antifreeze.

AXB Control Board Layout

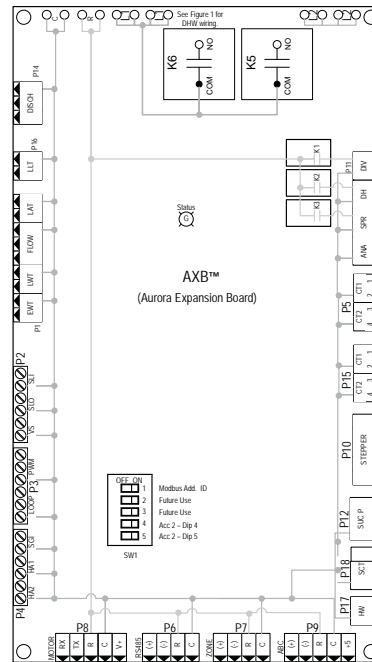

Communicating Digital Thermostats

The Aurora controls system also features either monochromatic or color touch screen graphic display thermostats for user interface. These displays not only feature easy to use graphical interface but display alerts and faults in plain English. Many of the features discussed here may not be applicable without these thermostats.

Dehumidification - Passive

In passive dehumidification mode, the airflow is reduced by 15% from the heating airflow setting. If cooling airflow is set to +5, -5 or -10% of heating airflow it will automatically be set to -15% of heating airflow whenever the dehumidification call is present in the communicating stat or from the thermostat input DH. If the airflow for cooling is already set to -15% no airflow change will be noticed from normal cooling. Dehumidification mode will be shown on the ABC and the communicating thermostats.

Aurora Controls cont.

Aurora 'Advanced' Control LED Displays

These three LEDs display the status, configuration, and fault codes for the control. These can also be read in plain English via the Aurora AID Tool.

Status LED (LED3, Green)

Description of Operation	Fault LED, Green
Normal Mode	ON
Control is Non-functional	OFF
Test Mode	Slow Flash
Lockout Active	Fast Flash
Dehumidification Mode	Flash Code 2
Load Shed	Flash Code 5
Emergency Shutdown	Flash Code 6
On Peak Mode	Flash Code 7
(Future Use)	Flash Code 8
(Future Use)	Flash Code 9

Configuration LED (LED2, Yellow)

Description of Operation	Configuration LED, Yellow
No Software Overwritten	ECM Setting
DIP Switch Overwritten	Slow Flash
ECM Configuration Mode	Fast Flash
Reset Configuration Mode	OFF

Fault LED (LED1, Red)

Red Fault LED		LED Flash Code *	Lockout	Reset/ Remove	Fault Condition Summary
ABC Basic Faults	Normal - No Faults	Off	-		
	Fault-Input	1	No	Auto	Tstat input error. Autoreset upon condition removal.
	Fault-High Pressure	2	Yes	Hard or Soft	HP switch has tripped (>600 psi)
	Fault-Low Pressure	3	Yes	Hard or Soft	Low Pressure Switch has tripped (<40 psi for 30 continuous sec.)
	Fault-Freeze Detection FP2	4	Yes	Hard or Soft	Freeze protection sensor has tripped (<15 or 30 degF for 30 continuous sec.)
	Fault-Freeze Detection FP1	5	Yes	Hard or Soft	Freeze protection sensor has tripped (<15 or 30 degF for 30 continuous sec.)
	Fault-Condensate Overflow	7	Yes	Hard or Soft	Condensate switch has shown continuity for 30 continuous sec.
	Fault-Over/Under Voltage	8	No	Auto	Instantaneous voltage is out of range. **Controls shut down until resolved.
ABC & AXB Advanced Faults	Fault-FP1 Sensor Error	11	Yes	Hard or Soft	FP1 Sensor Open or Shorted
	Fault-Compressor Monitor	10	Yes	Hard or Soft	Open Crkt, Run, Start or welded cont
	Non-CriticAXB SnsrErr	13	No	Auto	Any Other Sensor Error
	CriticAXBSnsrErr	14	Yes	Hard or Soft	Sensor Error for EEV or HW
	Alert-HotWtr	15	No	Auto	HW over limit or logic lockout. HW pump deactivated.
	Fault-VarSpdPump	16	No	Auto	Alert is read from PWM feedback.
	Non-CritComErr	18	No	Auto	Any non-critical com error
	Fault-CritComErr	19	No	Auto	Any critical com error. Auto reset upon condition removal
	Alarm - Low Loop Pressure	21	No	Auto	Loop pressure is below 3 psi for more than 3 minutes
	Alarm - Home Automation 1	23	No	Auto	Closed contact input is present on Dig 2 input - Text is configurable
Alarm - Home Automation 2	24	No	Auto	Closed contact input is present on Dig 3 input - Text is configurable	

NOTES: *All codes >11 use long flash for tens digit and short flash for the ones digit. 20, 30, 40, 50 etc. are skipped!
Alert' is a noncritical sensor or function that has failed. Normal operation of the heat pump is maintained but service is desired at some point.

Operation Logic Data Table

Operation Logic Table	Heating					Cooling			
	STG1	STG2	STG3	EMERG	Fan Only	STG1	STG2	Reheat	Fan Only
Compressor	On	On	On	Off	Off	On	On	On	Off
Reversing Valve	Off	Off	Off	Off	Off	On	On	On	On
Aux Heat	Off	Off	Staged	Staged	Off	Off	Off	Off	Off
Acc Relay	On	On	On	Off	Off	On	On	On	Off
Fan Relay (PSC)	On	On	On	On	On	On	On	On	On
Loop Pump	On	On	On	Off	Off	On	On	On	Off
Hot Water	On	On	Off	Off	Off	On	On	NA	Off
5-Speed ECM Speed	Med Low	Med High	High	High	Low	Med Low	Med High	High	Low
ECM Speed	Med	High	Aux	Aux	Low	Med	High	High	Low
T-Stat Signal	Y1	Y1,Y2	Y1,Y2,W	W	G	Y1,O	Y1,Y2,O	DH	G

Unit Startup

Before Powering Unit, Check The Following:

- Power supply matches nameplate specifications.
- Power supply fuses, breakers and wires are sized correctly.
- Switch the Transformer to 208V if applicable.
- Low voltage wiring complete.
- Piping completed and water system cleaned and flushed.
- Air is purged from closed loop system.
- Isolation valves are open, water control valves or loop pumps wired.
- Condensate line open and correctly pitched.
- Dip switches are set correctly.
- Blower wheel rotates freely and turns in the correct direction.
- Air filter/cleaner is clean and in position.
- Service/access panels are in place.
- Return air temperature is between 50-80oF heating and 60-95oF cooling.
- Evaluate air coil cleanliness to insure optimum performance. Clean as needed according to maintenance guidelines.

Startup Steps

NOTE: Complete the Equipment Start-Up/Commissioning Check Sheet during this procedure. Refer to thermostat operating instructions and complete the startup procedure.

1. Initiate a control signal to energize the blower motor. Check the blower operation.
2. Be sure the water control valve or loop pump(s) are activated.
3. Initiate a control signal to place the unit in the cooling mode. Cooling set point must be set below room temperature.
4. Cooling will energize after time delay. Check for correct rotation of scroll compressor in three (3) phase applications. Incorrect rotation will cause low refrigerant pressures and possibly unusual noise. Switch any two power leads at the compressor or contactor to reverse rotation.
5. Verify that the water flow rate is correct by measuring the pressure drop through the heat exchanger using the P/T plugs and comparing to the pressure drop table.
6. Check the temperature of both the supply and discharge water (Refer to Operating Parameters tables).
7. Check for an air temperature drop of 15oF to 25oF across the air coil, depending on the blower speed and entering water temperature.
8. Decrease the cooling set point several degrees and verify variable speed blower operation.
9. Adjust the cooling set point above the room temperature and verify that the compressor and water valve or loop pumps deactivate.
10. Initiate a control signal to place the unit in heating mode. Heating set point must be set above room temperature.
11. Heating will energize after a time delay.
12. Check the temperature of both the supply and discharge water (Refer to Unit Operating Parameters tables).
13. Check for an air temperature rise of 20oF to 35oF across the air coil, depending on the blower speed and entering water temperature.
14. If auxiliary electric heaters are installed, increase the heating set point until the electric heat banks are sequenced on. All stages of the auxiliary heater should be sequenced on when the thermostat is in the Emergency Heat mode. Check amperage of each element.
15. Adjust the heating set point below room temperature and verify that the compressor and water valve or loop pumps deactivate.
16. During the testing, check for excessive vibration, noise or water leaks. Correct or repair as required.
17. Set system to desired normal operation mode and set temperature to maintain desired comfort level.
18. Instruct the owner/operator in the proper operation of the thermostat and system maintenance.

NOTE: Be certain to fill out and forward all warranty registration papers.

Operating Limits

Operating Limits	Cooling		Heating	
	(°F)	(°C)	(°F)	(°C)
Air Limits				
Min. Ambient Air	45	7.2	45	7.2
Rated Ambient Air	80	26.7	70	21.1
Max. Ambient Air	100	37.8	85	29.4
Min. Entering Air	50	10.0	40	4.4
Rated Entering Air db/wb	80.6/66.2	27/19	68	20.0
Max. Entering Air db/wb	110/83	43/28.3	80	26.7
Water Limits				
Min. Entering Water	30	-1.1	20	-6.7
Normal Entering Water	50-110	10-43.3	30-70	-1.1
Max. Entering Water	120	48.9	90	32.2

NOTE: Minimum/maximum limits are only for start-up conditions, and are meant for bringing the space up to occupancy temperature. Units are not designed to operate at the minimum/maximum conditions on a regular basis. The operating limits are dependent upon three primary factors: 1) water temperature, 2) return air temperature, and 3) ambient temperature. When any of the factors are at the minimum or maximum levels, the other two factors must be at the normal level for proper and reliable unit operation.

Operating Parameters

First Stage Operation

Entering Water Temp °F	Water Flow gpm/ton	Cooling -- No Hot Water Generation					
		Suction Pressure psig	Discharge Pressure psig	Superheat	Subcooling	Water Temp Rise °F	Air Temp Drop °F DB
30	1.5	105 - 120	140 - 155	20 - 35	9 - 17	17 - 21	17 - 23
	3.0	100 - 115	115 - 130	20 - 35	9 - 17	8 - 12	17 - 23
50	1.5	125 - 140	205 - 225	12 - 20	8 - 14	17 - 21	17 - 23
	3.0	120 - 135	180 - 200	12 - 20	8 - 14	8 - 12	17 - 23
70	1.5	135 - 145	280 - 290	10 - 16	8 - 14	16 - 20	17 - 23
	3.0	133 - 143	250 - 260	10 - 16	8 - 14	9 - 13	17 - 23
90	1.5	142 - 152	345 - 355	8 - 12	8 - 14	14 - 20	17 - 23
	3.0	140 - 150	330 - 340	8 - 12	8 - 14	8 - 12	17 - 23
110	1.5	152 - 158	405 - 435	8 - 12	8 - 14	14 - 20	17 - 23
	3.0	148 - 153	390 - 420	8 - 12	8 - 14	8 - 12	17 - 23

Entering Water Temp °F	Water Flow gpm/ton	Heating -- No Hot Water Generation					
		Suction Pressure psig	Discharge Pressure psig	Superheat	Subcooling	Water Temp Drop °F	Air Temp Rise °F DB
30	1.5	76 - 84	270 - 285	8 - 12	3 - 10	5 - 9	12 - 16
	3.0	80 - 88	275 - 290	8 - 12	3 - 10	3 - 7	14 - 18
50	1.5	100 - 115	280 - 310	10 - 14	3 - 10	7 - 11	18 - 22
	3.0	105 - 120	290 - 315	10 - 14	3 - 10	5 - 9	20 - 24
70	1.5	135 - 150	310 - 325	12 - 16	3 - 10	8 - 12	24 - 28
	3.0	140 - 155	315 - 330	12 - 16	3 - 10	6 - 10	22 - 30
90	1.5	155 - 165	330 - 370	12 - 16	3 - 10	8 - 12	24 - 28
	3.0	160 - 170	340 - 380	12 - 16	3 - 10	6 - 10	22 - 30
110	1.5						
	3.0						

Note: Cooling performance based on entering air temperatures of 80° F DB, 67° F WB.
 Heating performance based on entering air temperature of 70° F DB.

10/1/10

Operating Parameters cont.

Second Stage Operation

Entering Water Temp °F	Water Flow gpm/ton	Cooling -- No Hot Water Generation					
		Suction Pressure psig	Discharge Pressure psig	Superheat	Subcooling	Water Temp Rise °F	Air Temp Drop °F DB
30	1.5	115 - 125	150 - 170	20 - 35	10 - 17	17 - 22	17 - 23
	3.0	105 - 120	130 - 145	20 - 35	10 - 17	8 - 10	17 - 23
50	1.5	130 - 140	215 - 235	12 - 20	8 - 14	16 - 22	17 - 23
	3.0	128 - 138	190 - 210	12 - 20	8 - 14	8 - 12	17 - 23
70	1.5	138 - 148	280 - 310	10 - 16	10 - 16	15 - 21	17 - 23
	3.0	136 - 146	250 - 280	10 - 16	8 - 14	7 - 13	17 - 23
90	1.5	145 - 155	350 - 380	9 - 14	10 - 16	14 - 20	17 - 23
	3.0	143 - 153	320 - 350	9 - 14	8 - 14	6 - 10	17 - 23
110	1.5	145 - 155	420 - 450	9 - 14	10 - 16	14 - 20	17 - 23
	3.0	143 - 153	405 - 435	9 - 14	8 - 14	6 - 10	17 - 23

Entering Water Temp °F	Water Flow gpm/ton	Heating -- No Hot Water Generation					
		Suction Pressure psig	Discharge Pressure psig	Superheat	Subcooling	Water Temp Drop °F	Air Temp Rise °F DB
30	1.5	73 - 85	270 - 305	8 - 14	3 - 10	6 - 10	15 - 21
	3.0	77 - 90	280 - 315	8 - 14	3 - 10	4 - 8	17 - 23
50	1.5	97 - 110	290 - 325	10 - 16	3 - 10	9 - 13	22 - 28
	3.0	102 - 115	300 - 335	10 - 16	3 - 10	7 - 11	24 - 30
70	1.5	130 - 145	320 - 355	13 - 19	3 - 10	10 - 14	30 - 36
	3.0	135 - 150	325 - 360	13 - 19	3 - 10	8 - 12	32 - 38
90	1.5	150 - 160	350 - 390	13 - 19	3 - 10	10 - 14	30 - 36
	3.0	155 - 165	365 - 405	13 - 19	3 - 10	8 - 12	32 - 38
110	1.5						
	3.0						

Note: Cooling performance based on entering air temperatures of 80° F DB, 67° F WB.
 Heating performance based on entering air temperature of 70° F DB.

10/1/10

Pressure Drop

Model	GPM	Pressure Drop (psi)					
		30°F	50°F	70°F	90°F	110°F	
Dual Capacity Compressor	084	10.0	1.7	1.5	1.3	1.0	0.8
		16.0	3.5	3.3	3.1	2.9	2.7
		22.0	7.1	6.0	5.33	4.9	4.7
	096	12.0	1.4	1.2	1.0	0.8	0.6
		18.0	2.8	2.6	2.4	2.2	2.0
		24.0	4.9	4.6	4.4	4.2	4.0
	120	16.0	0.8	0.7	0.7	0.6	0.5
		22.0	1.5	1.3	1.2	1.2	1.1
		30.0	3.0	2.8	2.6	2.4	2.2
Two Compressor	150	24.0	3.2	3.0	2.8	2.6	2.4
		30.0	5.1	4.9	4.7	4.5	4.3
		36.0	6.9	6.7	6.5	6.3	6.1
	180	22.0	1.8	1.6	1.4	1.2	1.0
		34.0	3.0	2.8	2.6	2.4	2.2
		45.0	4.2	4.0	3.6	3.3	3.1
	240	35.0	1.8	1.6	1.5	1.4	1.2
		50.0	3.0	2.8	2.6	2.4	2.2
		60.0	6.0	5.8	5.6	5.3	5.1
	300	35.0	2.8	2.6	2.4	2.2	2.0
		50.0	4.2	4.0	3.8	3.6	3.4
		75.0	7.6	7.3	7.0	6.4	6.0
	360	50.0	3.4	3.2	3.0	2.8	2.6
		70.0	6.1	5.9	5.7	5.5	5.3
		90.0	8.7	8.5	8.3	8.1	7.9

3/30/21

Reference Calculations

Heating Calculations:	Cooling Calculations:
$LWT = EWT - \frac{HE}{gpm \times 500}$	$LWT = EWT + \frac{HR}{gpm \times 500}$
$LAT = EAT + \frac{HC}{cfm \times 1.08}$	$LAT(DB) = EAT(DB) - \frac{SC}{cfm \times 1.08}$
$TH = HC + HWC$	$LC = TC - SC$
	$S/T = \frac{SC}{TC}$

Legend and Notes

ABBREVIATIONS AND DEFINITIONS:

cfm = airflow, cubic feet/minute	HE = total heat of extraction, MBtu/h
EWT = entering water temperature, Fahrenheit	HWC = hot water generator capacity, MBtu/h
gpm = water flow in gallons/minute	EER = Energy Efficient Ratio = BTU output/Watt input
WPD = water pressure drop, psi and feet of water	COP = Coefficient of Performance = Btu output/Btu input
EAT = entering air temperature, Fahrenheit (dry bulb/wet bulb)	LWT = leaving water temperature, °F
HC = air heating capacity, MBtu/h	LAT = leaving air temperature, °F
TC = total cooling capacity, MBtu/h	TH = total heating capacity, MBtu/h
SC = sensible cooling capacity, MBtu/h	LC = latent cooling capacity, MBtu/h
kW = total power unit input, kilowatts	S/T = sensible to total cooling ratio
HR = total heat of rejection, MBtu/h	

Notes (Refer to Performance Data tables)

- Performance ratings are based on 80°F DB / 67°F WB EAT for cooling and 70°F DB EAT for heating.
- Three flow rates are shown for each unit. The lowest flow rate shown is used for geothermal open loop/well water systems with a minimum of 50°F EWT. The middle flow rate shown is the minimum geothermal closed loop flow rate. The highest flow rate shown is optimum for geothermal closed loop systems and the suggested flow rate for boiler/tower applications.
- Entering water temperatures below 40°F assumes 15% antifreeze solution.
- For non-standard EAT conditions, apply the appropriate correction factors on (Refer to Correction Factor Tables).
- Interpolation between EWT, gpm, and cfm data is permissible.

Refrigerant Circuit Guideline

Symptom	Head Pressure	Suction Pressure	Compressor Amp Draw	Superheat	Subcooling	Air Temp. Differential	Water Temp. Differential
Under Charged System (Possible Leak)	Low	Low	Low	High	Low	Low	Low
Over Charged System	High	High	High	Normal	High	Normal/Low	Normal
Low Air Flow Heating	High	High	High	High/Normal	Low	High	Low
Low Air Flow Cooling	Low	Low	Low	Low/Normal	High	High	Low
Low Water Flow Heating	Low/Normal	Low/Normal	Low	Low	High	Low	High
Low Water Flow Cooling	High	High	High	High	Low	Low	High
High Air Flow Heating	Low	Low	Low	Low	High	Low	Low
High Air Flow Cooling	Low	High	Normal	High	Low	Low	Normal
High Water Flow Heating	Normal	Low	Normal	High	Normal	Normal	Low
High Water Flow Cooling	Low	Low	Low	Low	High	Normal	Low
Low Indoor Air Temperature Heating	Low	Low	Low	Normal	High	Normal	Normal/High
Low Indoor Air Temperature Cooling	Low	Low	Low	Normal/Low	High	Low	Low
High Indoor Air Temperature Heating	High	High	High	Normal/High	Normal/Low	Low	Normal
High Indoor Air Temperature Cooling	High	High	High	High	Low	Low	High
Restricted EEC (Check Service Advisory)	High	Low	Normal/Low	High	High	Low	Low
Insufficient Compressor (Possible Bad Valves)	Low	High	Low	High	Normal/High	Low	Low
Scaled Coaxial Heat Exchanger Heating	Low	Low	Low	Normal/Low	High	Low	Low
Scaled Coaxial Heat Exchanger Cooling	High	High	High	Normal/Low	Low	Low	Low
Restricted Filter Drier	Check temperature difference (delta T) across filter drier.						

8/25/16

Compressor and Thermistor Resistance

Compressor Resistance Chart

	Model	208-230/60/3	460/60/3	460/60/3
Dual Capacity	084	0.47-0.55	2.07-2.39	3.33-3.83
	096	0.47-0.54	1.85-2.13	3.33-3.83
	120	0.33-0.39	1.28-1.48	2.17-2.49
Two Compressor	150	0.68-0.78	2.09-2.41	4.01-4.61
	180	0.47-0.54	1.66-1.92	2.57-2.95
	240	0.33-0.39	1.28-1.48	2.17-2.49
	300	0.26-0.30	0.47-0.54	1.76-2.02
	360	0.2	0.83	1.32

1/17/2021

Thermistor Resistance Chart

Thermistor Resistance (10k Ohm) for FP1, FP2, HWL, LWT, LLT, and EWT	
Temperature (°F)	Resistance (Ohms)
5	75757-70117
14	57392-53234
23	43865-40771
32	33809-31487
41	26269-24513
50	20570-19230
59	16226-15196
68	12889-12093
77	10310-9688
86	8300-7812
95	6723-6337
104	5480-5172
113	4490-4246
122	3700-3504
131	3067-2907
140	2554-2424
149	2149-2019

1/21/21

Troubleshooting

Should a major problem develop, refer to the following information for possible causes and corrective steps.

If compressor won't run:

1. The fuse may be open or the circuit breaker is tripped. Check electrical circuits and motor windings for shorts or grounds. Investigate for possible overloading. Replace fuse or reset circuit breakers after fault is corrected.
2. Supply voltage may be too low. Check it with a volt meter.
3. Control system may be faulty. Check control for correct wiring of thermostat or aquastat and check the 24 volt transformer for proper voltage.
4. Wires may be loose or broken. Replace or tighten.
5. The low pressure switch may have tripped due to one or more of the following:
 - a) Heating
 - 1) Plugged heat exchanger on source side
 - 2) Water flow source side - (Low)
 - 3) Water too cold source side
 - 4) Low refrigerant
 - b) Cooling
 - 1) Plugged heat exchanger on load side
 - 2) Water flow load side - (Low)
 - 3) Water too cold load side
 - 4) Low refrigerant
6. The high pressure switch may have tripped due to one or more of the following:
 - a) Heating
 - 1) Plugged heat exchanger on load side
 - 2) Low water flow load side
 - 3) Water too warm load side
 - b) Cooling
 - 1) Plugged heat exchanger on source side
 - 2) Low water flow on source side
 - 3) Water too warm source side
7. The compressor overload protection may be open.
8. The internal winding of the compressor motor may be grounded to the compressor shell. If so, replace the compressor.
9. The compressor winding may be open or shorted. Disconnect power. Check continuity with ohm meter. If the winding is open, replace the compressor.

If sufficient cooling or heating is not obtained:

1. Check control for improper location or setting.
2. Check for restriction in water flow.
3. Check refrigerant subcooling and superheat for proper refrigerant charge and expansion valve operation.
4. The reversing valve may be defective and creating a bypass of refrigerant. If the unit will not heat, check the reversing valve coil.

If the unit operation is noisy:

1. Check compressor for loosened mounting bolts. Make sure compressor is floating free on its isolator mounts. Check for tubing contact with the compressor or other surfaces. Readjust it by bending slightly.
2. Check screws on all panels.
3. Check for chattering or humming in the contactor or relays due to low voltage or a defective holding coil. Replace the component.
4. Check for proper installation of vibration absorbing material under the unit.
5. Check for abnormally high discharge pressures.
6. Compressor rotation incorrect

Refrigerant Systems

To maintain sealed circuit integrity, do not install service gauges unless unit operation appears abnormal. Compare the change in temperature on the air side as well as the water side to the Operating Parameters tables. If the unit's performance is not within the ranges listed, and the airflow and water flow are known to be correct, gauges should then be installed and superheat and subcooling numbers calculated. If superheat and subcooling are outside recommended ranges, an adjustment to the refrigerant charge may be necessary.

NOTE: Refrigerant tests must be made with hot water generator turned "OFF". Verify that air and water flow rates are at proper levels before servicing the refrigerant circuit.

Startup and Troubleshooting Form

Company Name: _____ Company Phone No: _____
 Technician Name: _____ Date: _____
 Model No: _____ Serial No: _____
 Owner's Name: _____ Open or Closed Loop: _____
 Installation Address: _____ Installation Date: _____

Check One

Start up/Check-out for new installation Troubleshooting Problem: _____

1. FLOW RATE IN GPM (COAXIAL HEAT EXCHANGER)

Water In Pressure: a. _____ PSI
 Water Out Pressure: b. _____ PSI
 Pressure Drop = a - b c. _____ PSI
 Convert Pressure Drop to Flow Rate
 (refer to *Pressure Drop* table) d. _____ GPM

2. TEMPERATURE RISE OR DROP ACROSS COAXIAL HEAT EXCHANGER

	COOLING	HEATING
Water In Temperature:	e. _____ °F	e. _____ °F
Water Out Temperature:	f. _____ °F	f. _____ °F
Temperature Difference:	g. _____ °F	g. _____ °F

3. TEMPERATURE RISE OR DROP ACROSS AIR COIL

	COOLING	HEATING
Air In Temperature:	h. _____ °F	h. _____ °F
Air Out Temperature:	i. _____ °F	i. _____ °F
Temperature Difference:	j. _____ °F	j. _____ °F

4. HEAT OF REJECTION (HR) / HEAT OF EXTRACTION (HE) CALCULATION

HR or HE = Flow Rate x Temperature Difference x Brine Factor*
 d. (above) x g. (above) x 485 for Methanol or Environol, 500 for water*
 Heat of Extraction (Heating Mode) = _____ btu/hr
 Heat of Rejection (Cooling Mode) = _____ btu/hr
 Compare results to Capacity Data Tables

Note: Steps 5 through 8 need only be completed if a problem is suspected

5. WATTS

	COOLING	HEATING
Volts:	m. _____ VOLTS	m. _____ VOLTS
Total Amps (Comp. + Fan):	n. _____ AMPS	n. _____ AMPS
Watts = m. x n. x 0.85	o. _____ WATTS	o. _____ WATTS

6. CAPACITY

Cooling Capacity = HR. - (o. x 3.413) p. _____ btu/hr
 Heating Capacity= HE. + (o. x 3.413) p. _____ btu/hr

7. EFFICIENCY

Cooling EER = p. / o. q. _____ EER
 Heating COP = p. / (o. x 3.413) q. _____ COP

8. SUPERHEAT (S.H.) / SUBCOOLING (S.C.)

	COOLING	HEATING
Suction Pressure:	r. _____ PSI	r. _____ PSI
Suction Saturation Temperature:	s. _____ °F	s. _____ °F
Suction Line Temperature:	t. _____ °F	t. _____ °F
Superheat = t. - s.	u. _____ °F	u. _____ °F
Head Pressure:	v. _____ PSI	v. _____ PSI
High Pressure Saturation Temp.:	w. _____ °F	w. _____ °F
Liquid Line Temperature*:	x. _____ °F	x. _____ °F
Subcooling = w. - x.	y. _____ °F	y. _____ °F

* Note: Liquid line is between the coaxial heat exchanger and the expansion valve in the cooling mode; between the air coil and the expansion valve in the heating mode.

DEALER: _____
 PHONE #: _____ DATE: _____
 PROBLEM: _____
 MODEL #: _____
 SERIAL #: _____



Startup/Troubleshooting Form

COOLING CYCLE ANALYSIS

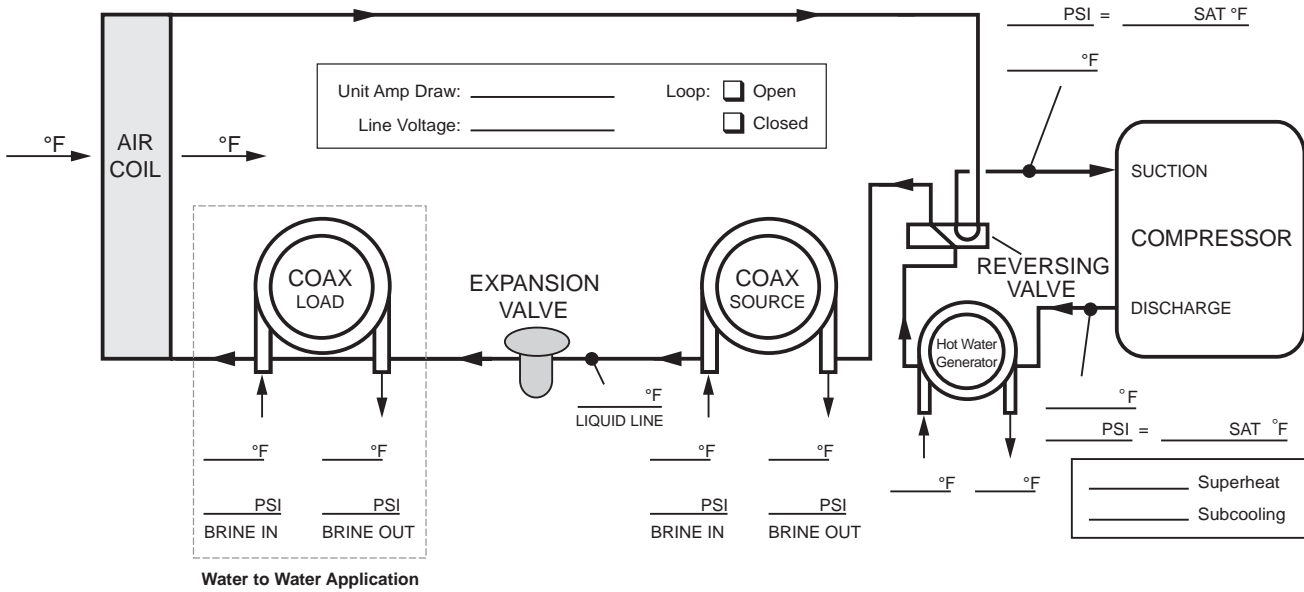

Heat of Extraction/Rejection = GPM x 500 (485 for water/antifreeze) x ΔT

Note: DO NOT hook up pressure gauges unless there appears to be a performance problem.

HEATING CYCLE ANALYSIS

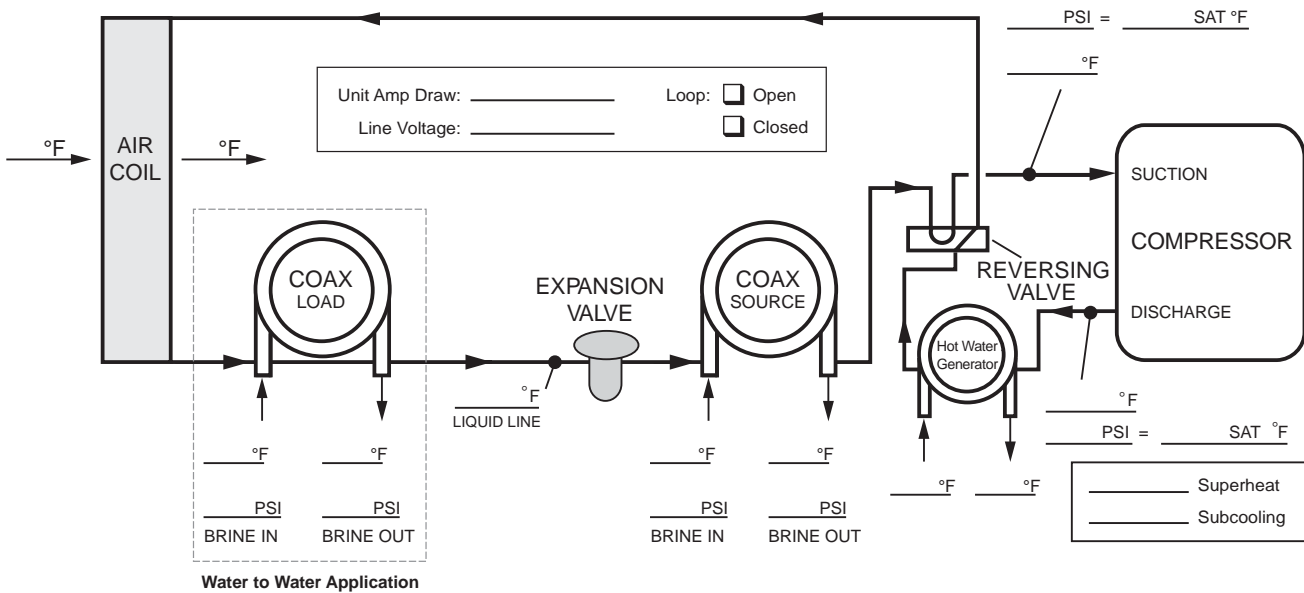

Preventive Maintenance

Water Coil Maintenance

1. Keep all air out of the water. An open loop system should be checked to ensure that the well head is not allowing air to infiltrate the water line. Lines should always be airtight.
2. Keep the system under pressure at all times. It is recommended in open loop systems that the water control valve be placed in the discharge line to prevent loss of pressure during off cycles. Closed loop systems must have positive static pressure.

NOTE: On open loop systems, if the installation is in an area with a known high mineral content (125 PPM or greater) in the water, it is best to establish with the owner a periodic maintenance schedule so the coil can be checked regularly. Should periodic coil cleaning be necessary, use standard coil cleaning procedures which are compatible with either the cupronickel or copper water lines. Generally, the more water flowing through the unit the less chance for scaling.

Other Maintenance

Filters

Filters must be clean to obtain maximum performance. They should be inspected monthly under normal operating conditions and be replaced when necessary. Units should never be operated without a filter.

Condensate Drain

In areas where airborne bacteria produce a slime in the drain pan, it may be necessary to treat chemically to minimize the problem. The condensate drain can pick up lint and dirt, especially with dirty filters. Inspect twice a year to avoid the possibility of overflow.

Blower Motors

Blower motors are equipped with sealed ball bearings and require no periodic oiling.

Air Coil

The air coil must be cleaned to obtain maximum performance. Check once a year under normal operating conditions and, if dirty, brush or vacuum (with a brush attachment) clean. Care must be taken not to damage the aluminum fins while cleaning.



CAUTION: Fin edges are sharp.

Replacement Procedures

Obtaining Parts

When ordering service or replacement parts, refer to the model number and serial number of the unit as stamped on the serial plate attached to the unit. If replacement parts are required, mention the date of installation of the unit and the date of failure, along with an explanation of the malfunctions and a description of the replacement parts required.

In-Warranty Material Return

Material may not be returned except by permission of authorized warranty personnel. Contact your local distributor for warranty return authorization and assistance.

Revision Guide

Pages:	Description:	Date:	By:
24	Added Waterside Economizer performance data	30 May 2023	MA
17-24, 31	Insert Take-a-part instructions, add weights table	16 Feb 2023	MA
3	Nomenclature Update	05 Mar 2022	JM
Cover	Name Update	10 Jan 2022	JM
All	Document Creation	15 July 2021	JM



Manufactured by
WaterFurnace International, Inc.
9000 Conservation Way
Fort Wayne, IN 46809
www.waterfurnace.com



IM2770AU 02/24

Product:	Versatec 500
Type:	Water Source/Geothermal Heat Pump
Size:	7-30 Tons
Document:	Installation Manual